

COMPACT S

*Installation, operating
and maintenance instructions*



excellence in hot water

INTRODUCTION	1
Who should read these instructions	1
Symbols	1
Applicable standards	1
Important notes	1
DESCRIPTION	2
General description	2
Packing	3
TECHNICAL CHARACTERISTICS	4
Dimensions	4
General characteristics	4
INSTALLATION	5
Boiler room	5
Heating connections	6
Wiring diagram	7
Preparing the boiler and Mounting the casing cover	8
Mounting the burner	8
Commissioning	8
SERVICING	9
Servicing the boiler	9
SERVICE RECORD	10
Details of the installation	10
Service engineer's report	10

WHO SHOULD READ THESE INSTRUCTIONS

These instructions should be read by:

- specifying engineers
- installers
- users
- service engineers

SYMBOLS

The following symbols are used in these instructions:



Essential instruction for the correct operation of the equipment.



Essential instruction for the safety of persons and the environment.



Electric shock hazard.



Burning hazard.

APPLICABLE STANDARDS

The products are "CE" approved, according to the standards in force in the various countries (European Directives 92/42/CEE "Efficiency", 90/396/CEE "Gas appliances").



IMPORTANT NOTES

These instructions are an integral part of the equipment to which they relate and must be handed to the user.

The product must be installed and serviced by qualified engineers in accordance with current standards in force.

ACV declines all liability for any damage caused as a result of incorrect installation or in the event of the use of appliances or accessories that are not specified by ACV.



Failure to follow the instructions describing the tests and procedures may cause injury to persons or a risk of environmental pollution.

N.B.:

ACV reserves the right to change the technical characteristics and specification of its products without prior notice.

DESCRIPTIONS

GENERAL DESCRIPTION

Boiler body

The boiler is made from ST 37/2 heavy gauge steel sheets according to NBN D 06001 and DIN 4702 Teil 1 with a water-cooled combustion chamber.

Pressurised fire-tube boiler with removable baffles The boiler body is hydraulically tested in the factory (*Max. service pressure = 5 bar*).

Burner chamber plate

The very solid burner chamber plate opens to the left or right and is insulated by a ceramic fibre stone placed on a bed of rock wool. The chamber plate seal is by means of a ceramic fibre cord and four M12 screw fastening.

Flue gas case

The flue gas case is removable and made from steel 3mm thick. It is secured with 6 M10 nuts. The flue gas case includes a cleaning window at the bottom, 150mm in diameter.

Casing

The lining is all steel. It was scoured and phosphated before painting. The casing is stove enamelled at 200°C, providing a guarantee of both long life and a high-quality finish. Epoxy-polyester protection

Insulation

The COMPACT S boiler is doubly insulated:

- A coating on the boiler body using a rock wool bedding 100mm thick.
- A coating on the casing panels using 25mm thick rock wool bedding with aluminium coating.

Safety

- The COMPACT S boiler includes a safety mode device in the event the chamber plate is not closed.
- A manual reset high-limit thermostat is triggered every time the boiler overheats above a temperature of 103°C.

Packing

The boiler is supplied on a wooden base with the casing, insulation and control panel unit in a wooden crate.

Basic settings

1. Thermometer
2. First firing control thermostats
3. Second firing control thermostats
4. Manual reset high limit thermostat
5. Main switch
6. Door safety indicator light

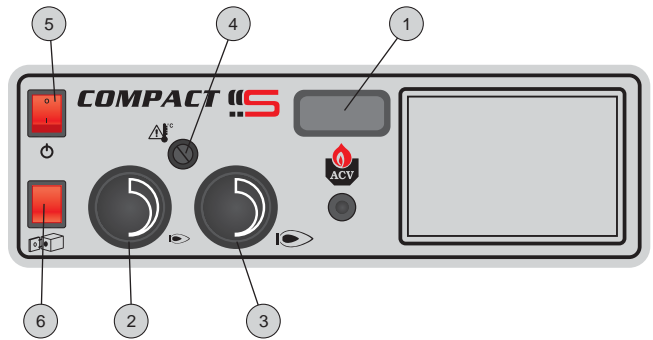

Operating diagram key

1. Control panel
2. Evaporation of condensation at start-up
3. Door double insulation
4. Burner
5. Heat return at low temperature
6. Safety valve connection
7. Heating outlet
8. Flue gas case
9. Cleaning window
10. Heating circuit
11. Combustion chamber
12. Drain

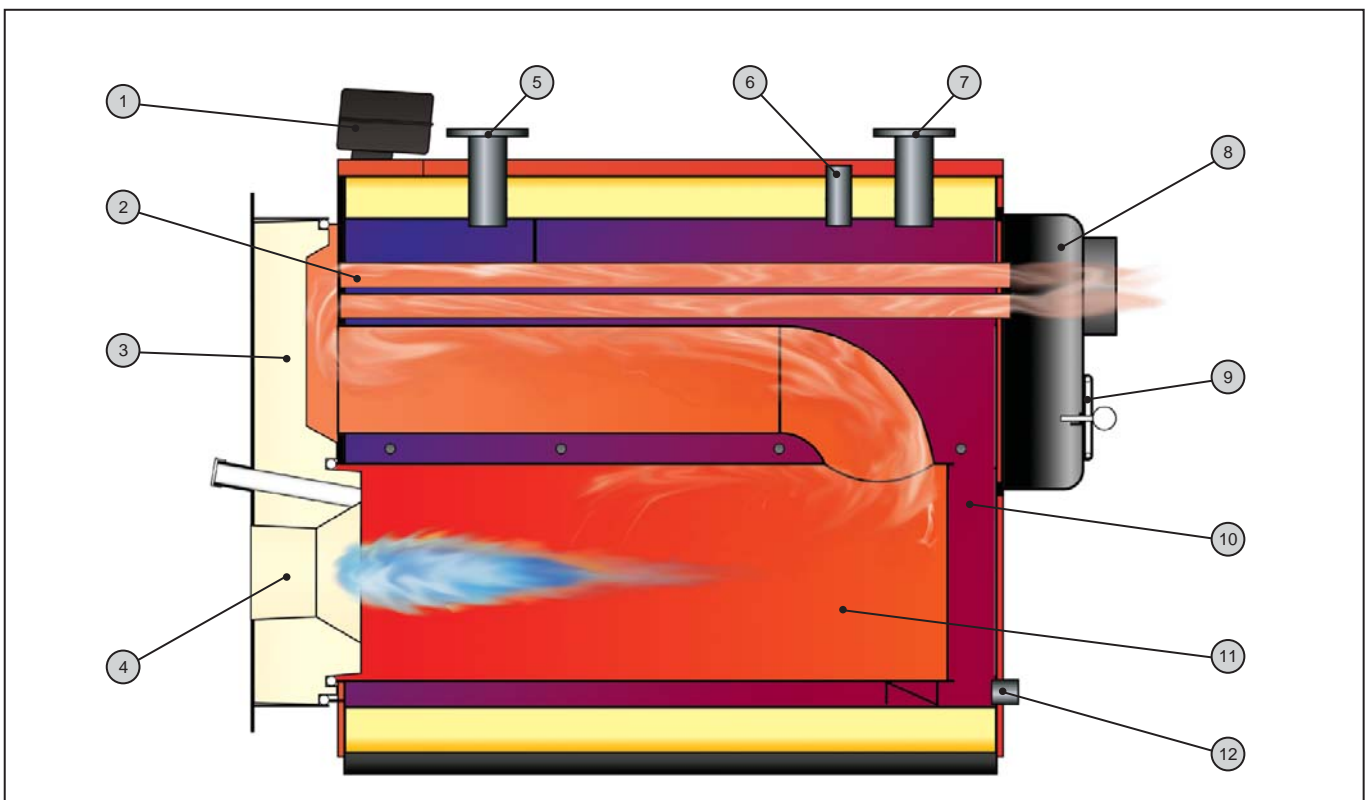

PACKING

The boiler comes in two packages.

- Package 1: the boiler body on a wooden pallet
- Package 2: metal casings in a cardboard box

In the boiler combustion chamber, you will find:

- The control panel in its wrapping.
- The standard accessories

Breakdown of the accessories

COMPACT S 180 - 230:

- Ceramic fibre insulation cord
- Propylene spool
- Lock loop
- Cleaning brush
- Brush handle
- Brush handle extension
- DN 65 companion flanges
- Seal — fastenings - bolts
- 40mm thick rock wool

COMPACT S 290 - 350 - 410:

- Ceramic fibre insulation cord
- Propylene spool
- Lock loop
- Cleaning brush
- Brush handle
- Brush handle extension
- DN 80 companion flanges
- Seal — fastenings - bolts
- 40mm thick rock wool

COMPACT S 470 - 520 - 580 - 640:

- Ceramic fibre insulation cord
- Propylene spool
- Lock loop
- Cleaning brush
- Brush handle
- Brush handle extension
- DN 100 companion flanges
- Seal — fastenings - bolts
- 40mm thick rock wool

Contents of package 2

- Front right and left side panels
- Rear right and left side panels
- Upper right and left side panels

Package 1



Package 2



Breakdown of the accessories



TECHNICAL CHARACTERISTICS

DIMENSIONS

Key

- T1: Ø flue gas outlet
- T2: Ø boiler drain
- T3: Ø return
- T4: Ø outlet
- T5: sleeve / clamp for safety valve, if applicable.
- 1: Control panel
- 2: Flame inspection window
- 3: Boiler clamp

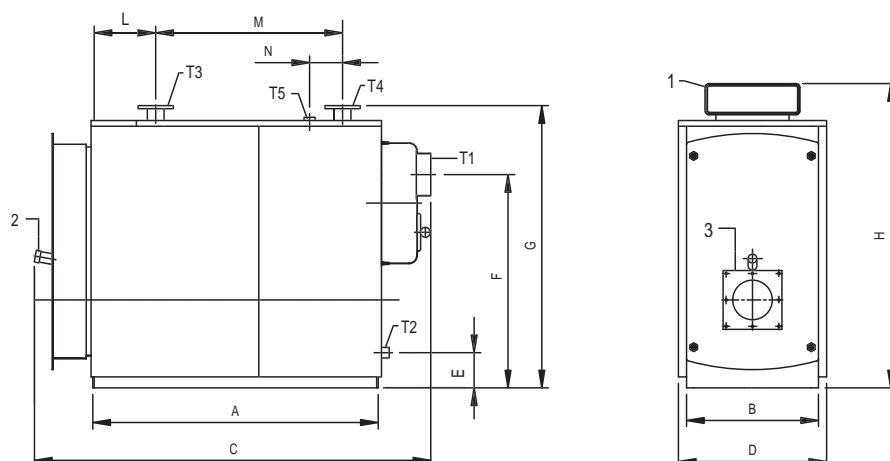

Model		180	230	290	350	410	470	520	580	640
A	mm	1300	1300	1504	1504	1504	1742	1742	1742	1742
B	mm	600	600	720	720	720	780	780	780	780
C	mm	1870	1870	2135	2135	2135	2395	2395	2395	2395
D	mm	672	672	792	792	792	852	852	852	852
E	mm	160	160	160	160	160	190	190	190	190
F	mm	960	960	1200	1200	1200	1365	1365	1365	1365
G	mm	1295	1295	1540	1540	1540	1700	1700	1700	1700
H	mm	1390	1390	1600	1600	1600	1770	1770	1770	1770
L	mm	280	280	440	440	440	440	440	440	440
M	mm	850	850	830	830	830	1050	1050	1050	1050
N	mm	150	150	250	250	320	320	320	320	320
T1	Ø	200	200	200	200	200	250	250	250	250
T2	DN	1"1/4	1"1/4	1"1/4	1"1/4	1"1/4	1"1/4	1"1/4	1"1/4	1"1/4
T3-T4	DN	65	65	80	80	80	100	100	100	100
T5	DN	1"1/4	1"1/4	50	50	50	65	65	65	65

GENERAL CHARACTERISTICS

Model		180	230	290	350	410	470	520	580	640
Output	kW	176.5	235.8	294.7	354.4	412.9	471.9	531.9	588.5	648.7
Input	kW	190.2	255.7	318.2	384.0	448.3	509.8	575.6	639.7	707.4
Efficiency at rated load	%	92.8	92.2	92.6	92.3	92.1	92.5	92.4	92.0	91.7
Heat efficiency at 30% reduced load	%	88.5	88.6	88.7	88.9	89.2	89.3	89.4	89.5	89.6
Combustion efficiency	%	94.3	93.6	94.0	93.6	93.4	93.8	93.6	93.1	92.7
Maintenance losses	%	1.5	1.4	1.4	1.35	1.3	1.3	1.2	1.15	1.05
Losses by chimney when in operation	%	5.7	6.4	6.0	6.35	6.6	6.2	6.4	6.85	7.25
Losses by chimney when off	%	0.1	0.1	0.1	0.1	0.1	0.1	0.1	0.1	0.1
Percentage of CO ₂ (note 1)	%	13.0	13.0	13.0	12.5	12.6	12.5	12.6	12.7	13.0
Flue gas temperature (note 1)	°C	185	188	190	193	195	190	193	195	198
Combustion chamber pressure	daPa	9	13	18	23	26	27	29	32	36
Boiler water content	l	290	290	456	456	456	681	681	681	681
Unladen weight	Kg	590	620	925	950	990	1130	1150	1170	1190

BOILER ROOM

Boiler positioning and installation

Comply with local standards in force (in Belgium: "Belgique NBN B 61-001") for all special characteristics, relative to the dimensions, fire resistance of the panels, steel chamber plates, chimneys and upper- and lower-level ventilations.

The following formula is used to calculate the flue ways section:

$$S = 0.0065 Q_c / \square H$$

S expressed in cm² / Q_c = Kcal/h; H = m. For the special metal flue ways, we recommend that you consult the chimney manufacturer for each specific case.

To facilitate cleaning the flue gas circuits during servicing, make sure you leave a space in front of your **COMPACT S** that is longer than the length of the boiler itself and ensure that the burner chamber plate can open easily when assembled.

Your **COMPACT S** must be placed on a concrete base, approximately 20 - 30cm high, to ensure the correct burner position and to protect it from dampness.

To reduce vibrations and noises, make sure the boiler is placed on the level and that it is stable.

At this point, connect the boiler to the electrical supply and install the flue gas chimney, in accordance with current standards in force.

- A. High-level ventilation
- B. Low-level ventilation
- C. Draught stabiliser
- D. Flame inspection window
- E. Chimney height
- F. Chimney diameter
- H. Connection nozzle

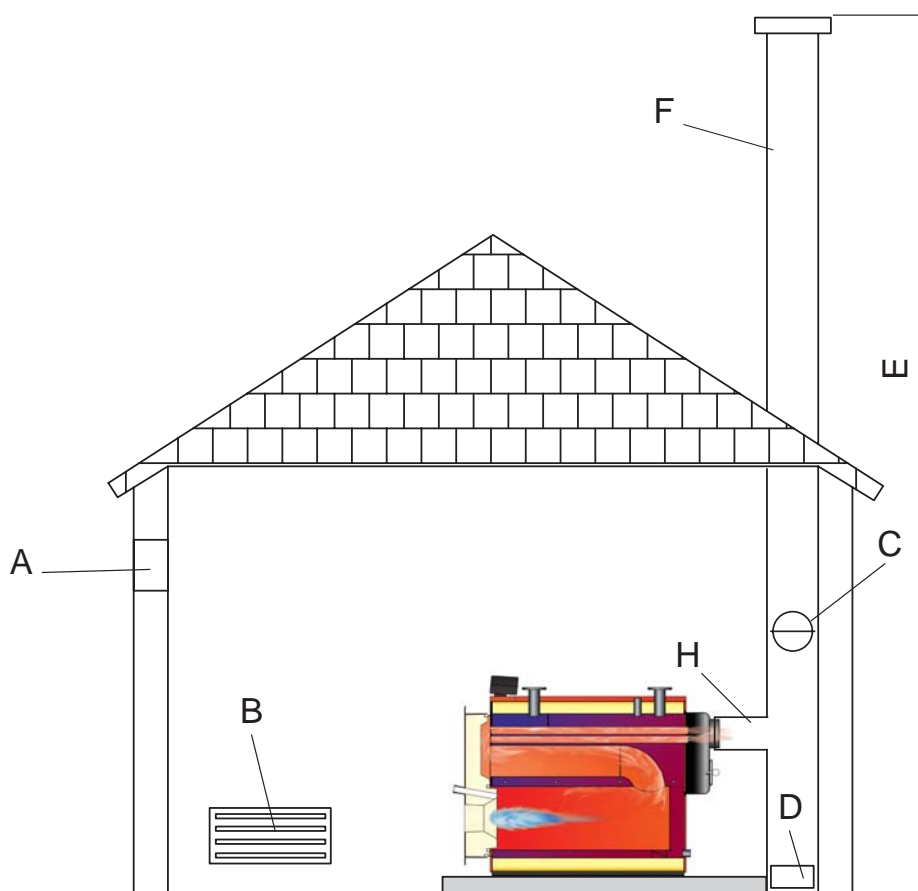

Model		180	230	290	350	410	470	520	580	640
Minimum fresh air supply	m ³ /h	343	460	573	690	807	918	1036	1151	2122
High-level ventilation	dm ²	3	3	3	3	3	3	3	4	4
Low-level ventilation	dm ²	5.7	7.7	9.6	11.5	13.5	15.3	17.3	19.2	21.2

Ø of the chimney pipe:

Height 5m	mm	317	366	410	449	485	518	550	579	608
Height 10m	mm	267	308	344	378	408	436	463	487	511
Height 15m	mm	241	278	311	341	368	394	418	440	462
Height 20m	mm	224	259	290	317	343	367	389	409	430

INSTALLATION

Minimum boiler positioning clearances

Minimum boiler room dimension:

- Minimum height: 2.5 m
- Minimum area: 6.0 m²
- Distance between the walls and the boiler: 600 mm
- Distance between the walls and the burner: 1300 mm
- Distance between the boiler and the ceiling: 1000 mm
- Fire resistance of the structures: 120 minutes



Before installing, check the local regulations in force in your country.

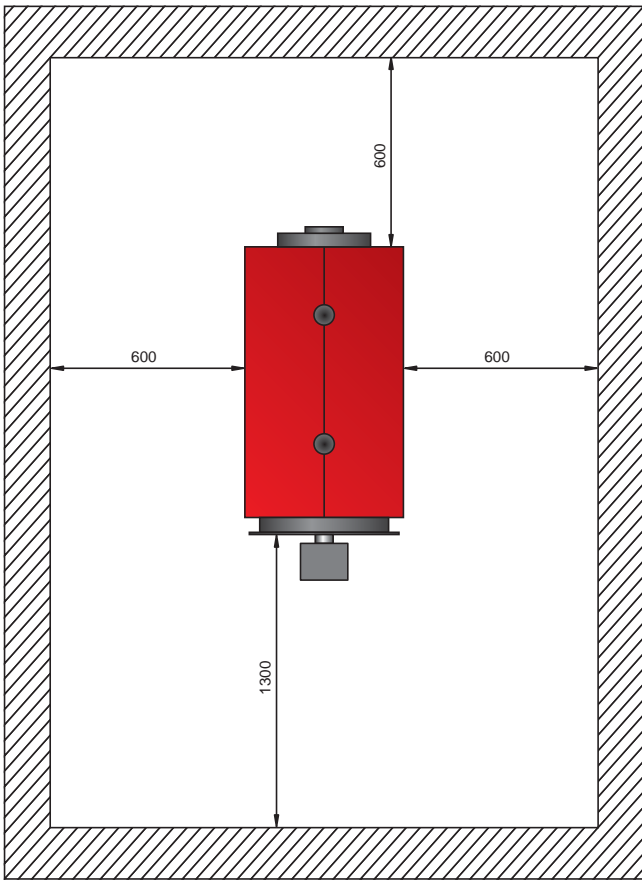

HEATING CONNECTION



Beware!

Each boiler must be fitted with a safety valve, calibrated to a maximum pressure of 5 bar. Fit the safety valve to the top point of the boiler. You must make sure that no setting or insulation parts will allow it to be disabled (See page 4).

It is vital that the **COMPACT S** boiler is equipped with a primary "H" circulation loop:

- to avoid localised overheating in the combustion chamber;
- to mix part of the outlet fluid with the return fluid (increase in the return temperature);

Important note:

- The installer must place the minimum-temperature thermostat on the boiler body. This will cut the power to the heating pump when the return temperature is too low.
- The installer must also connect the primary pump.

- A. Mixing control valve
- B. Pump
- C. Expansion vessel
- D. Safety valve
- E. Drain cock
- F. Pressure gauge
- G. Non-return valve
- H. Recirculation loop with pump and non-return valve
- K. Isolating valve

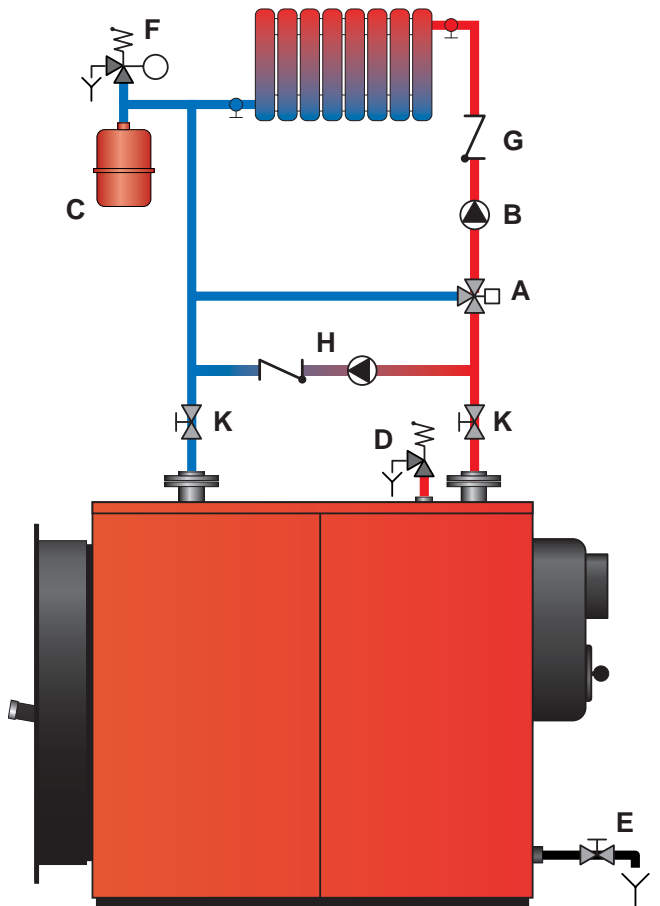

ELECTRICAL WIRING DIAGRAM



It is compulsory to install an electrical control box outside your COMPACT S with a main switch and 6A fuses. Before carrying out any work on the equipment, it is vital to switch off the electrical power from this box.

The connection of the chamber plate safety switch is payable by the customer.



N.B.:
To wire the burner, please refer to the burner instructions, supplied with the boiler only when supplying a thermal unit.

Key to the boiler's electrical wiring

- IG. Main switch
- MIP. Chamber plate safety dip switch
- S. Door closed indicator light
- TS. High-limit thermostat
- TM1. First firing thermostat
- TM2. Second firing thermostat

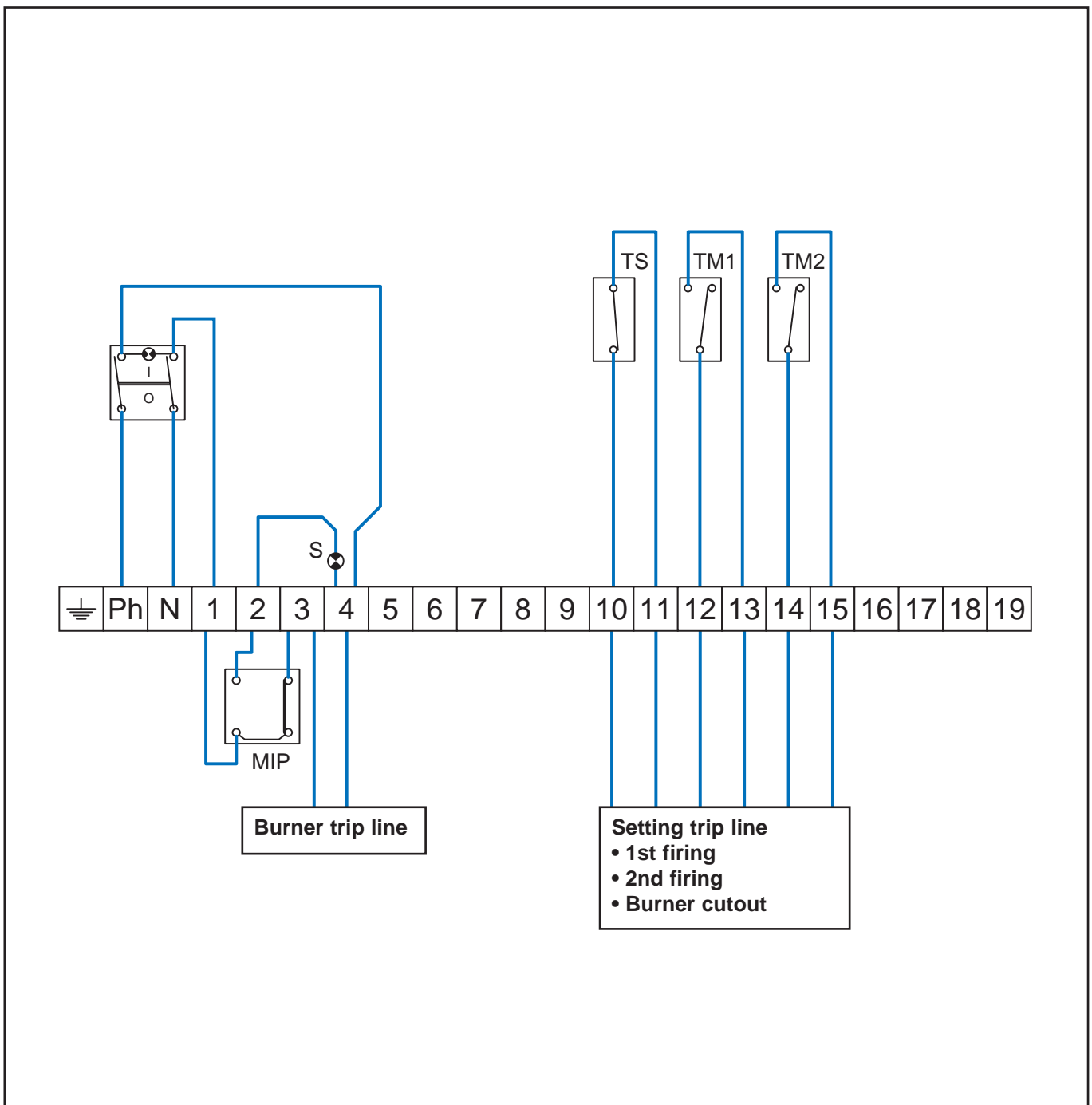

INSTALLATION

PREPARING THE BOILER AND MOUNTING THE CASING

Please refer to the assembly instructions supplied with the casing.

MOUNTING THE BURNER

Only a qualified technician may mount the burner, in compliance with current standards in force.

When installing the burner, we recommend you:

- secure the burner plate using all the nuts provided to guarantee the seal;
- guarantee a minimum burner penetration in the combustion chamber, according to the indications in the table below;
- check that the burner gas tube is sized according to the gas supply pressure;
- check that the burner can exceed the boiler combustion chamber pressure;
- insert the fiberglass cord supplied into the empty space between the boiler combustion head and the chamber plate insulating panel (if the quality is not sufficient — this depends on the Ø of the burner head — use more cord to fill the space up to the inside surface of the chamber plate insulation) to prevent the plate from overheating from the effect of the flue gases, which could deform the chamber plate;
- adjust the flame to optimize the use of the combustion chamber without touching the bottom or the panels.

Please see the previous page for the electrical wiring diagram for the control panel

COMMISSIONING

Filling the system:

- Make sure that all the system valves are open except the drain cock. Place the 3- or 4-channel mixing valve to the middle position.
- Drain the system and monitor the pressure;
 - hydrostatic height ... with the expansion vessel open.
 - hydrostatic height + 0.5 bar in closed systems.

Commissioning the burner:

- Check the burner charge relative to the boiler's output.
- Check that all the safety parts are correctly calibrated and connected: safety valve, expansion vessel and thermostats.
- Check that the pumps are functioning normally.
- Open the system's valves.
- Commissioning the burner:

Checks:

- First check the burner charge, then adjust the settings and check the combustion characteristics — flue gas T° - CO₂ - CO and blackening index.
- check that the settings and high-limit thermostats are operating correctly; check the low-limit thermostat and the chamber plate opening switch.
- Check that the safety valve is operating correctly (max pressure = 5 bar) by activating it manually.
- Check that the ventilation in the boiler room is adequate and check that the chimney is conform.
- Check that the return temperature is not less than 40°C, that the recirculation loop is connected and that it is operating correctly.

Recommendations:

- If the burner shuts down, wait for a few minutes before trying to ignite it.
- Shut off the main switch before carrying out any work on the boiler.
- Quality of the heating circuit water - The quality of the water is a key factor for the lifetime of the boiler:
 - total hardness < 15°F
 - pH of 6 to 8
 - free oxygen < 0.5ppm
 - free of sludge: (*clean the system before connecting the new boiler*).Poor quality water can cause lime scale deposits and corrosion of the inside surface of the heating body
- Consult a specialist water treatment company if the heating water does not comply with the characteristics given above.
- Avoid locating boilers in poorly ventilated basement areas. The high- and low-level ventilations must comply with current regulations.
- Provide a self-regulating draught valve on the chimney.

Thermostat settings:

- Set the slow firing rate thermostat (2) to the desired operating t°.
- Set the high firing rate thermostat (3) to a t° of 10°C lower than the slow firing speed thermostat.

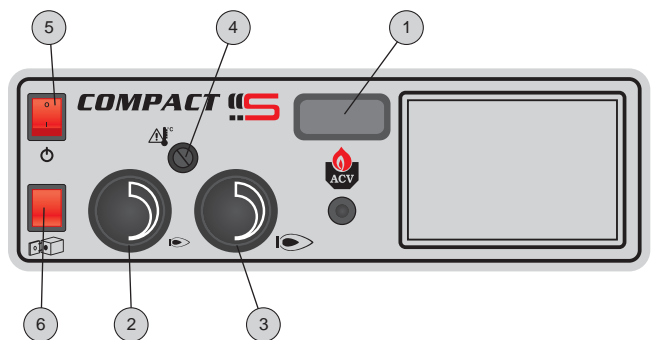

SERVICING THE BOILER

You should have the boiler serviced at least once a year. Regular servicing reduces consumption and extends the lifetime of your boiler.

To clean the boiler, follow the steps below:

- Disconnect the burner (trigger the main switch).
- Open the chamber plate.
- Remove the steel baffles.
- Clean the flue ways with a wire brush.
- Return the baffles.
- Clean the combustion chamber and remove any residues.
- Unscrew and remove the steel plate from the flue gas case.
- Clean the flue gas case, replace the plate and screw to tighten (check that it is properly sealed).
- Clean the burner combustion head and the ignition electrodes.
- Close the chamber plate and re-start the system.

SERVICE RECORD

DETAILS OF THE INSTALLATION

Installation date: _____	Flue gas T°: _____	Model: _____
% CO ₂ (min. load): _____	Efficiency: _____	Serial number: _____
% CO ₂ (max. load): _____	Gas pressure: _____	Heating system pressure setting: _____
<input type="checkbox"/> Gas <input type="checkbox"/> Propane		
<input type="checkbox"/> Fuel oil	Name and signature: _____	

SERVICE ENGINEER'S REPORT

Service date: _____	Flue gas T°: _____	Comments: _____
% CO ₂ (min. load): _____	Efficiency: _____	_____
% CO ₂ (max. load): _____	Gas pressure: _____	_____
<input type="checkbox"/> Gas <input type="checkbox"/> Propane		
<input type="checkbox"/> Fuel oil	Name and signature: _____	

Service date: _____	Flue gas T°: _____	Comments: _____
% CO ₂ (min. load): _____	Efficiency: _____	_____
% CO ₂ (max. load): _____	Gas pressure: _____	_____
<input type="checkbox"/> Gas <input type="checkbox"/> Propane		
<input type="checkbox"/> Fuel oil	Name and signature: _____	

Service date: _____	Flue gas T°: _____	Comments: _____
% CO ₂ (min. load): _____	Efficiency: _____	_____
% CO ₂ (max. load): _____	Gas pressure: _____	_____
<input type="checkbox"/> Gas <input type="checkbox"/> Propane		
<input type="checkbox"/> Fuel oil	Name and signature: _____	

Service date: _____	Flue gas T°: _____	Comments: _____
% CO ₂ (min. load): _____	Efficiency: _____	_____
% CO ₂ (max. load): _____	Gas pressure: _____	_____
<input type="checkbox"/> Gas <input type="checkbox"/> Propane		
<input type="checkbox"/> Fuel oil	Name and signature: _____	

Service date: _____	Flue gas T°: _____	Comments: _____
% CO ₂ (min. load): _____	Efficiency: _____	_____
% CO ₂ (max. load): _____	Gas pressure: _____	_____
<input type="checkbox"/> Gas <input type="checkbox"/> Propane		
<input type="checkbox"/> Fuel oil	Name and signature: _____	

Service date: _____	Flue gas T°: _____	Comments: _____
% CO ₂ (min. load): _____	Efficiency: _____	_____
% CO ₂ (max. load): _____	Gas pressure: _____	_____
<input type="checkbox"/> Gas <input type="checkbox"/> Propane		
<input type="checkbox"/> Fuel oil	Name and signature: _____	

Service date: _____	Flue gas T°: _____	Comments: _____
% CO ₂ (min. load): _____	Efficiency: _____	_____
% CO ₂ (max. load): _____	Gas pressure: _____	_____
<input type="checkbox"/> Gas <input type="checkbox"/> Propane		
<input type="checkbox"/> Fuel oil	Name and signature: _____	

Service date: _____	Flue gas T°: _____	Comments: _____
% CO ₂ (min. load): _____	Efficiency: _____	_____
% CO ₂ (max. load): _____	Gas pressure: _____	_____
<input type="checkbox"/> Gas <input type="checkbox"/> Propane		
<input type="checkbox"/> Fuel oil	Name and signature: _____	

Service date: _____	Flue gas T°: _____	Comments: _____
% CO ₂ (min. load) : _____	Efficiency: _____	_____
% CO ₂ (max. load) : _____	Gas pressure: _____	_____
<input type="checkbox"/> Gas <input type="checkbox"/> Propane		
<input type="checkbox"/> Fuel oil	Name and signature: _____	

Service date: _____	Flue gas T°: _____	Comments: _____
% CO ₂ (min. load) : _____	Efficiency: _____	_____
% CO ₂ (max. load) : _____	Gas pressure: _____	_____
<input type="checkbox"/> Gas <input type="checkbox"/> Propane		
<input type="checkbox"/> Fuel oil	Name and signature: _____	

Service date: _____	Flue gas T°: _____	Comments: _____
% CO ₂ (min. load) : _____	Efficiency: _____	_____
% CO ₂ (max. load) : _____	Gas pressure: _____	_____
<input type="checkbox"/> Gas <input type="checkbox"/> Propane		
<input type="checkbox"/> Fuel oil	Name and signature: _____	

SERVICE RECORD

Service date:	Flue gas T°:	Comments:
% CO ₂ (min. load):	Efficiency:	
% CO ₂ (max. load):	Gas pressure:	
<input type="checkbox"/> Gas <input type="checkbox"/> Propane		
<input type="checkbox"/> Fuel oil	Name and signature:	

Service date:	Flue gas T°:	Comments:
% CO ₂ (min. load):	Efficiency:	
% CO ₂ (max. load):	Gas pressure:	
<input type="checkbox"/> Gas <input type="checkbox"/> Propane		
<input type="checkbox"/> Fuel oil	Name and signature:	

Service date:	Flue gas T°:	Comments:
% CO ₂ (min. load):	Efficiency:	
% CO ₂ (max. load):	Gas pressure:	
<input type="checkbox"/> Gas <input type="checkbox"/> Propane		
<input type="checkbox"/> Fuel oil	Name and signature:	

Service date:	Flue gas T°:	Comments:
% CO ₂ (min. load):	Efficiency:	
% CO ₂ (max. load):	Gas pressure:	
<input type="checkbox"/> Gas <input type="checkbox"/> Propane		
<input type="checkbox"/> Fuel oil	Name and signature:	

Service date:	Flue gas T°:	Comments:
% CO ₂ (min. load) :	Efficiency:	
% CO ₂ (max. load) :	Gas pressure:	
<input type="checkbox"/> Gas <input type="checkbox"/> Propane		
<input type="checkbox"/> Fuel oil	Name and signature:	

Service date:	Flue gas T°:	Comments:
% CO ₂ (min. load) :	Efficiency:	
% CO ₂ (max. load) :	Gas pressure:	
<input type="checkbox"/> Gas <input type="checkbox"/> Propane		
<input type="checkbox"/> Fuel oil	Name and signature:	



excellence in hot water

www.acv-world.com

INTERNATIONAL

ACV international n.v
KERKPLEIN, 39
B-1601 RUISBROEK - BELGIUM
TEL.: +32 2 334 82 20
FAX: +32 2 378 16 49
E-MAIL: international.info@acv-world.com

BELGIUM

ACV BELGIUM nv/sa
KERKPLEIN, 39
B-1601 RUISBROEK-BELGIUM
TEL.: +32 2 334 82 40
FAX: +32 2 334 82 59
E-MAIL: belgium.info@acv-world.com

CHILE

ALBIN TROTTER Y ACV LTDA
SAN PABLO 3800
QUINTA NORMAL - SANTIAGO - CHILE
TEL.: +56 2 772 01 69
FAX: +56 2 772 92 62/63
E-MAIL: chile.info@acv-world.com

CZECH REPUBLIC

ACV CR SPOL. s.r.o
NA KRECKU 365
CR-109 04 PRAHA 10 - CZECH REPUBLIC
TEL.: +420 2 720 83 341
FAX: +420 2 720 83 343
E-MAIL: ceskarepublika.info@acv-world.com

DEUTSCHLAND

ACV WÄRMETECHNIK GMBH & CO KG
GEWERBEGBIET GARTENSTRASSE
D-08132 MÜLSEN OT ST. JACOB - DEUTSCHLAND
TEL.: +49 37601 311 30
FAX: +49 37601 311 31
E-MAIL: deutschland.info@acv-world.com

ESPAÑA

ACV ESPAÑA
C/DE LA TEIXIDORA, 76
POL. IND. LES HORTES
E-08302 MATARÓ - ESPAÑA
TEL.: +34 93 759 54 51
FAX: +34 93 759 34 98
E-MAIL: spain.info@acv-world.com

ARGENTINA

TECNO PRACTICA
ALFEREZ BOUCHARD 4857
1605 CARAPACHAY - BUENOS AIRES
TEL.: +54 11 47 65 33 35
FAX: +54 11 47 65 43 07
E-MAIL: jchas@tecnopractica.com

AUSTRALIA

HUNT HEATING PTY LTD
10 GARDEN BOULEVARD
3172 VICTORIA - AUSTRALIA
TEL.: +61 3 9558 7077
FAX: +61 3 9558 7027
E-MAIL: enquiries@huntheat.com.au

BRAZIL

SIMETAL INDUSTRIA E COMERCIO DE FERRAMENTAS LTDA
RUA GERSON ANDREIS 535
95112 - 130 CAXIAS DO SUL - BRAZIL
TEL.: +55 54 227 12 44
FAX: +55 54 227 12 26
E-MAIL: export@simetail.com.br

BULGARIA

PROXIMUS ENGINEERING LTD
7 BIAL KREM STR.
9010 VARNNA - BULGARIA
TEL.: +359 52 500 070
FAX: +359 52 301 131
E-MAIL: info@proximus-bg.com

CHINA

BEIJING HUADIAN HT POWER TECHNOLOGY DEVELOPMENT CO. LTD
ROOM B-912, TOWER B, COFCO PLAZA
Nº. 8, JIANGUOMENNEI AVENUE
BEIJING 100005 - PEOPLE'S REPUBLIC OF CHINA
TEL.: +86 10 652 30 363/393 EXT 101
FAX: +86 10 652 27 071
E-MAIL: li.zheng@acv-world.com

SHANGHAI COOLTECH LTD

14/F E. CHINA MERCHANTS PLAZA
Nº. 333 CHENGDU ROAD (N)
200041 SHANGHAI - CHINA
TEL.: +86 21 52 98 11 22 - 820
FAX: +86 21 52 98 13 58
E-MAIL: cooltech@cooltech.sh.cn

FRANCE

ACV FRANCE sa
31, RUE AMPERE - Z.I MI - PLAINE
F-69680 CHASSIEU - FRANCE
TEL.: +33 4 72 47 07 76
FAX: +33 4 72 47 08 72
E-MAIL: france.info@acv-world.com

ITALIA

ACV ITALIA
VIA PANA 92
I-48018 FAENZA (RA) - ITALIA
TEL.: +39 0546 64 61 44
FAX: +39 0546 64 61 50
E-MAIL: italia.info@acv-world.com

NEDERLAND

ACV NEDERLAND bv
POSTBUS 350
NL-2980 AJ RIDDERKERK - NEDERLAND
TEL.: +31 180 42 10 55
FAX: +31 180 41 58 02
E-MAIL: nederland.info@acv-world.com

POLAND

ACV POLSKA sp. z o.o.
UL. WITOSA 3
87 - 800 WWCOWAWEK - POLAND
TEL.: +48 54 412 56 00
FAX: +48 54 412 56 01
E-MAIL: polska.info@acv-world.com

PORTUGAL

BOILERNOX LDA
RUA OUTEIRO DO POMAR
CASAL DO CEGO, FRACÇÃO C,
PAVILHÃO 3 - MARRAZES
2400-402 LEIRIA - PORTUGAL
TEL.: +351 244 837 239/40
FAX: +351 244 823 758
E-MAIL: boilernox@mail.telepac.pt

RUSSIA

ACV RUSSIA
1/9, MALYI KISELNYI
103031 MOSCOW - RUSSIA
TEL.: +7 095 928 48 02 / +7 095 921 89 79
FAX: +7 095 928 08 77
E-MAIL: russia.info@acv-world.com

DENMARK

VARMEHuset
FRICHSVEJ 40 A
8600 SILKEBORG - DENMARK
TEL.: +45 86 82 63 55
FAX: +45 86 82 65 03
E-MAIL: vh@varmehuset.dk

ESTONIA

TERMOMAX AS
TAHE 112A
51013 TARTU - ESTONIA
TEL.: +372 736 73 39
FAX: +372 736 73 44
E-MAIL: termomax@termomax.ee

GREECE

ESTIAS
MARASLI STREET 7
54248 THESSALONIKI - GREECE
TEL.: +30 23 10 31 98 77 / +30 23 10 32 03 58
FAX: +30 23 10 31 97 22
E-MAIL: info@genikithermanseon.gr

ÎLE MAURICE

SOTRATECH
29, RUE MELDRUM
BEAU BASSIN - ÎLE MAURICE
TEL.: +230 46 76 970
FAX: +230 46 76 971
E-MAIL: stech@intnet.mu

LITHUANIA

UAB "GILIUS IR KO"
SAVARNORIŲ PR. 192
3000 KAUNAS - LITHUANIA
TEL.: +370 37 308 930
FAX: +370 37 308 932

MAROC

CASATHERM
PLACE EL YASSIR
20300 CASABLANCA - MAROC
TEL.: +212 22 40 15 23
FAX: +212 22 24 04 86

SLOVAK REPUBLIC

ACV SLOVAKIA s.r.o.
PLUHOVÁ 49
831 04 BRATISLAVA - SLOVAK REPUBLIC
TEL.: +421 2 444 62 276
FAX: +421 2 444 62 275
E-MAIL: slovakia.info@acv-world.com

SLOVENIA

ACV D.O.O. SLOVENIA
OPEKARNA 22b
1420 TRBOVLJE - SLOVENIA
TEL.: +386 356 32 830
FAX: +386 356 32 831
E-MAIL: slovenia.info@acv-world.com

UK

ACV UK Ltd
ST. DAVID'S BUSINESS PARK
DALGETY BAY - FIFE - KY11 9PF
TEL.: +44 1383 82 01 00
FAX: +44 1383 82 01 80
E-MAIL: uk.info@acv-world.com

USA

TRIANGLE TUBE PHASE III
FREEWAY CENTER - 1 TRIANGLE LANE
BLACKWOOD NJ 08012 - USA
TEL.: +1 856 228 8881
FAX: +1 856 228 3584
E-MAIL: sales@triangletube.com

MOLDAVIA

STIMEX - PRIM S.R.L.
STR BUCURESTI, 60A
2012 CHISINAU - MOLDAVIA
TEL.: +37 32 22 46 75
FAX: +37 32 24 56
E-MAIL: stimex@slavik.mldnet.com

NEW ZEALAND

ENERGY PRODUCTS INTERNATIONAL
8/10 BELFAST PLACE
PO BOX 15058 HAMILTON - NEW ZEALAND
TEL.: +64 7 847 27 05
FAX: +64 7 847 42 22
E-MAIL: pmckenzie@tycoint.com

ÖSTERREICH

PROTHERM HEIZUNGSTECHNIK GmbH
TRAUNFERNSTRASSE 113
4052 ANSFELDEN - ÖSTERREICH
TEL.: +43 7229 804 82
FAX: +43 7229 804 92
E-MAIL: protherm@nexttra.at

ROMANIA

SC TRUST EURO THERM SA
D.N PIATRA NEAMT - ROMAN
km 2 C.P 5 O.P 3 jud. Neamt
5600 PIATRA NEAMT - ROMANIA
TEL.: +40 233 20 62 06
FAX: +40 233 20 62 00
E-MAIL: office@eurotherm.ro

TUNISIE

SO.CO.ME CHAUMAX
BOÎTE POSTALE N°44
1002 TUNIS - TUNISIE
TEL.: +216 71 78 15 91
FAX: +216 71 78 87 31

UKRAINE

UKRTEPLOSERVICE LTD
PR. LAGUTENKO 14
83086 DONETSK - UKRAINE
TEL.: +38 062 382 60 47/48
FAX: +38 062 335 16 89