

The Worcester Bosch 26CDi XTRA Gas-Fired Combination Boiler

TECHNICAL AND SPECIFICATION INFORMATION

gas-fired combination boilers from Worcester Bosch

GAS-FIRED

STANDARD FLUE
LENGTH 100-1000mm



Worcester Bosch supports
the Benchmark code of practice

The 26CDi XTRA combi boiler

Total heating and hot water comfort

The 26CDi XTRA combi boiler

Features

- Stainless steel secondary heat exchanger.
- Built-in filling loop.
- Plug-in digital and mechanical timeclocks.
- Plug-in radio controlled room thermostat.
- Wall mounted jig.
- Optional anti-theft security fixings.
- Electronic ignition.
- Built-in frost protection.
- Pump seizure protection.
- Fault finding diagnostics.
- Modulation control.
- Built-in boiler bypass.
- Anti-cycle device.
- No ventilation grills required in compartments.
- B.E.D. approved as a condensing boiler.

Benefits

- Maximises efficiency.
- Labour and money saving.
- No electrician required.
- No disruption to floorboards etc.
- Allows pre-fabrication of system.
- Greatly reduces risk of theft when installed.
- Energy saving.
- Money saving, economical protection.
- Prevents call-backs.
- Time saving.
- Energy saving.
- Labour and money saving.
- Energy saving.
- Labour and money saving.
- Higher SAP and NHER ratings.

Building on the great success of the advanced CDi series of gas combi boilers, Worcester Bosch is delighted to introduce yet another exciting and innovative development – the exceptional 26CDi XTRA condensing combi boiler.

Here is a combi that boasts a remarkably high level of operating efficiency. By employing a second heat exchanger to extract the latent heat from the flue gases normally

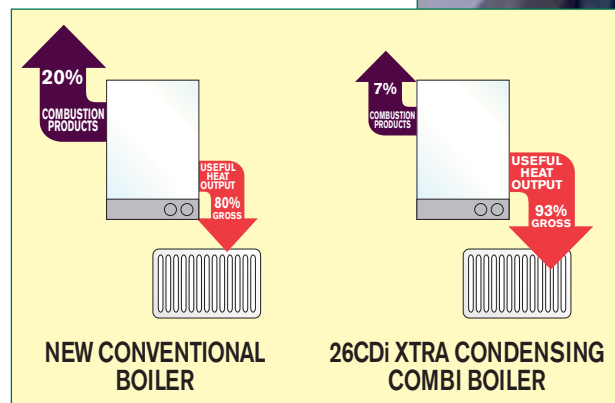

discharged straight out into the atmosphere, the 26CDi XTRA ensures that as much as 93% of the gas it burns is converted into heat for central heating and hot water. This compares with around 80% for other types of boiler.

In terms of the running costs, the 26CDi XTRA could reduce domestic heating and hot water bills by 15%-20% compared with a new conventional boiler, and up to 30% over old boilers.

What's more, 26CDi XTRA is excellent news for the environment. Emissions of carbon dioxide are significantly reduced, while such efficient use of energy is acknowledged by experts to be one of the best ways of helping to minimise both environmental damage and the threat of climate change.

Another major benefit of the 26CDi XTRA is that it is designed specifically to meet the needs and lifestyles of British households.

And, of course, it is built in Britain at the advanced Worcester Bosch manufacturing centre. Which means it comes complete with all the built-in benefits of proven CDi combi boiler technology.

The 26CDi XTRA combi boiler Total heating and hot water comfort



The 26CDi XTRA combi boiler ● The advantages of a combi system

The 26CDi XTRA combi system layout ● Installing the 26CDi XTRA
● 26CDi XTRA horizontal fluing options

Installation requirements

The 26CDi XTRA accessories ● Worcester Bosch training

After-sales ● Full range of Worcester Bosch gas combination boilers

The 26CDi XTRA at a glance

| | 26CDi XTRA |
|---------------------|--------------------------|
| Output kW | 6.7 - 24kW 6.7 - 26kW |
| Flow rate at 35° | 9.5 lt/min |
| CH & DHW control | ✓ |
| Modulating control | ✓ |
| Natural gas | ✓ |
| LPG | ✓ |
| Electronic ignition | ✓ |

The 26CDi XTRA combi boiler

The advantages of a combi system

A combi (or combination boiler) is a compact and highly efficient unit giving all the heating and hot water you need, with significant savings on running and installation costs.

Unlike a conventional heating and hot water system, a combi boiler system does not store domestic hot water. It heats water directly from the cold mains – as you use it. There's no hot water cylinder, no tank in the loft (and so less risk of freezing and flooding), and none of the connecting pipework. So you not only save space, but also reduce hot water costs – which can account for up to 60% of a typical domestic fuel bill.



A combi also supplies hot water at mains pressure, giving you exhilarating power showering without the need for a pump. And as, on average, a shower uses considerably less water than a typical bath, the savings on hot water costs and water consumption can be significant.

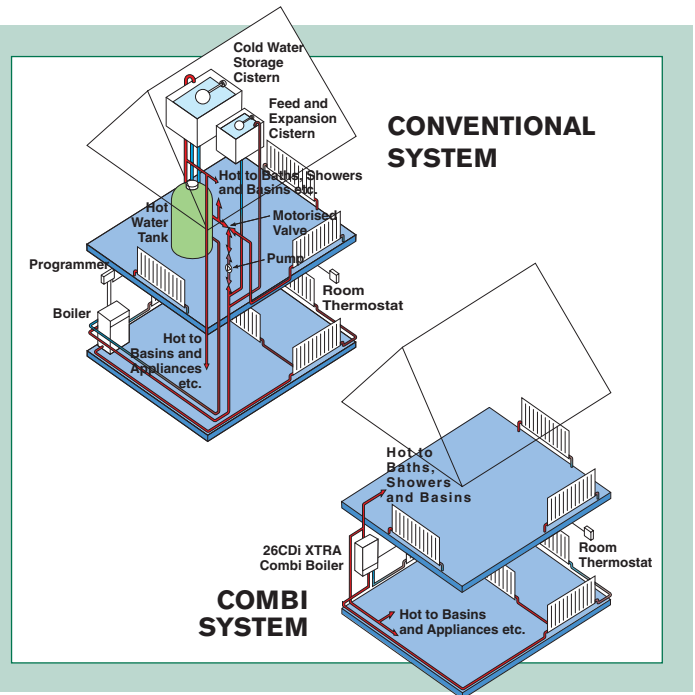

The Worcester Bosch 26CDi XTRA condensing Combi is an attractive and compact wall-mounted boiler which can meet the heating and hot water requirements of a variety of households and lifestyles.

The major components are all contained within the single unit, namely a low-water-content boiler, a separate plated domestic hot water exchanger, a secondary stainless steel heat exchanger, sealed system equipment, circulating pump, diverter valve, and other electronic and mechanical equipment needed to provide mains-fed hot water and full central heating.

What's more, the 26CDi XTRA is supplied completely pre-wired and pre-plumbed, and offers fluing options to suit most applications. It also benefits from several important time-saving installation features, as described in detail on page 7.

Why the 26CDi XTRA is so efficient

As explained, a Worcester Bosch CDi gas combi boiler has many advantages over a conventional boiler.

The 26CDi XTRA is a condensing combi – which means it takes the concept even further to produce yet bigger savings and economies. The secret lies in the fact that it has two primary heat exchangers instead of one. The second heat exchanger is positioned in the path of the flue gases. It then extracts the latent heat from these gases (heat that otherwise would be lost into the atmosphere) and applies it to the system.

It is this ability to extract as much heat as possible from the gas it burns that gives the 26CDi XTRA an exceptionally high level of operating efficiency. This higher efficiency is recognised within the building regulations subsequently achieving a higher SAP or NHER rating.



The 26CDi XTRA design benefits in operation

Key features of the 26CDi XTRA include the separate plated domestic hot water heat exchanger, which is guaranteed for 5 years. It ensures more efficient heat-up and normally eliminates the need for a scale inhibitor, thus saving on installation costs.

Modulating central heating and domestic hot water outputs, combined with separate consumer controls, also mean that comfortable temperature levels for both can be set independently of each other.

Hot Water mode

Whenever a hot water tap is turned on, the incoming water mains will activate an electro/mechanical diverter valve which, via the electronic control system, ignites the burner. Boiler output is automatically boosted to maximum to heat the incoming cold water as it passes through the hot water heat exchanger. Electronic controls modulate the boiler output downwards to ensure that the hot water temperature remains between 40-65°C (as set by the consumer).

Central Heating mode

On demand for central heating, the boiler will initially operate at minimum output, before modulating upwards to meet the actual system demand, electronics within the boiler continually monitor the heating flow temperature increasing or decreasing output on demand. A built in bypass and automatic anti-cycling device make the 26CDi XTRA particularly suitable for use on systems where thermostatic radiator valves are to be used.

* Subject to conditions.

The 26CDi XTRA combi boiler

Options

Fluing

The 26CDi XTRA is available as RSF version only and is designed for use with a multi-directional fanned flue system. The flue can be run horizontally to the left, right or rear, providing an extremely flexible and versatile fluing system which allows the appliance to be sited almost anywhere.

Horizontal flue

The 26CDi XTRA RSF is supplied as standard with a 100mm diameter concentric flue pipe 1000mm in length, when measured from the appliance side casing. The flue turret enables the flue to be routed a full 360° circumference around the appliance in 90° rotations. An extended flue system 2000mm in length is available (please note the flue cannot be joined).

Vertical flue

In addition to the horizontal flue, the 26CDi XTRA has the facility of a vertical option. This enables vertical fluing runs of up to 3000mm (including terminal)

Optional security features

- Security 'Plug in boiler'
 - Shear/off bolts
 - Electronic tagging devices
 - Customised fascia panels
 - Control panel removal
- Further details can be found in our leaflet No. 8-716-153-005.

Versatility

Gas

The 26CDi XTRA is manufactured for both natural gas and LPG applications.

Controls

The control panel features:

- Power on/off switch.
- Central heating on/off and temperature control selector.
- Domestic hot water temperature control selector.
- A series of 4 indicator lights that display the different stages of boiler operation.



Plug-in programmer

Plug in controls

For added comfort a choice of programmers is available. The simple-to-operate 24 hour single channel mechanical programmer can be set at 15 minute intervals.

The 7 day single channel electronic programmer enables your central heating programme to be varied for each day of the week should you require it.

One of the many advanced features of the 26CDi XTRA is the optional radio-controlled room thermostat. Battery powered, the Digistat CD 24 hour fully programmable thermostat digitally displays actual room temperature and works by means of proven radio technology. It therefore requires no wiring whatsoever, with major installation



Radio-controlled room thermostat



24 Hour Mechanical Programmer



7 Day Digital Programmer



Fully Programmable Radio Frequency Controlled Room Thermostat

benefits such as far greater siting flexibility and none of the problems of cable runs, chasing out brick or plasterwork and lifting carpets and floorboards.

Within the building regulations for new properties the minimum of controls should be a programmer and interlocking room thermostat together with the ability to operate the upstairs (sleeping accommodation) at different temperatures to downstairs, (lounge, kitchen etc.), i.e. TRV's.

A Digistat CD functions as a combined time clock and room thermostat thus complying with these requirements when used in conjunction with thermostatic radiator valves.

Applications

- With a heating output of up to 26kW and a domestic hot water flow rate of 9.5 litre/min (2.1gpm) at 35°C the 26CDi XTRA is suitable for most sizes of one bathroom properties.
- As the 26CDi XTRA delivers hot water at mains pressure it is ideally suited to providing a powerful shower.
- The 26CDi XTRA can be sited where space and water storage is a problem.
- The 26CDi XTRA is particularly suitable for starter homes, as the appliance may be used for hot water only with radiators being added at a later date.
- With its ability to modulate down to 6.7kW, the 26CDi XTRA operates at optimum efficiency, even on low heating loads.

Technical data

| Classification | 26CDi room sealed fanned |
|--|--|
| Output to Central Heating | 6.7 - 24kW 22,800 - 82,000 Btu/hr (Non Condensing) 6.7 - 26kW 22,800 - 88,700 Btu/hr (Condensing) |
| DHW Flow Rate @ 35°C | 9.5 litres/min (2.1 gallons/min) |
| Lift Weight | 50kg |
| Primary Water Content | 3.6 litres |
| Maximum Domestic Water Inlet Pressure | 10bar (15psi) |
| Minimum Domestic Water Inlet Pressure for maximum DHW Rate | 1.2bar (18psi) |
| Minimum Domestic Water Inlet Pressure to Operate the Appliance | 0.7bar (10psi) |
| Central Heating Flow | 22mm compression |
| Central Heating Return | 22mm compression |
| Mains Cold Water Inlet | 15 mm compression |
| Domestic Hot Water Outlet | 15mm compression |
| Gas Inlet RC | RP 3/4 |
| Pressure Relief Drain | G 1/2" |
| Condensation Syphon | 22mm (3/4" plastic pipe) |
| Casing Height | 850mm |
| Casing Width | 450mm |
| Casing Depth | 360mm |
| SEDBUK | 85.7% Band C |

The 26CDi XTRA inside story

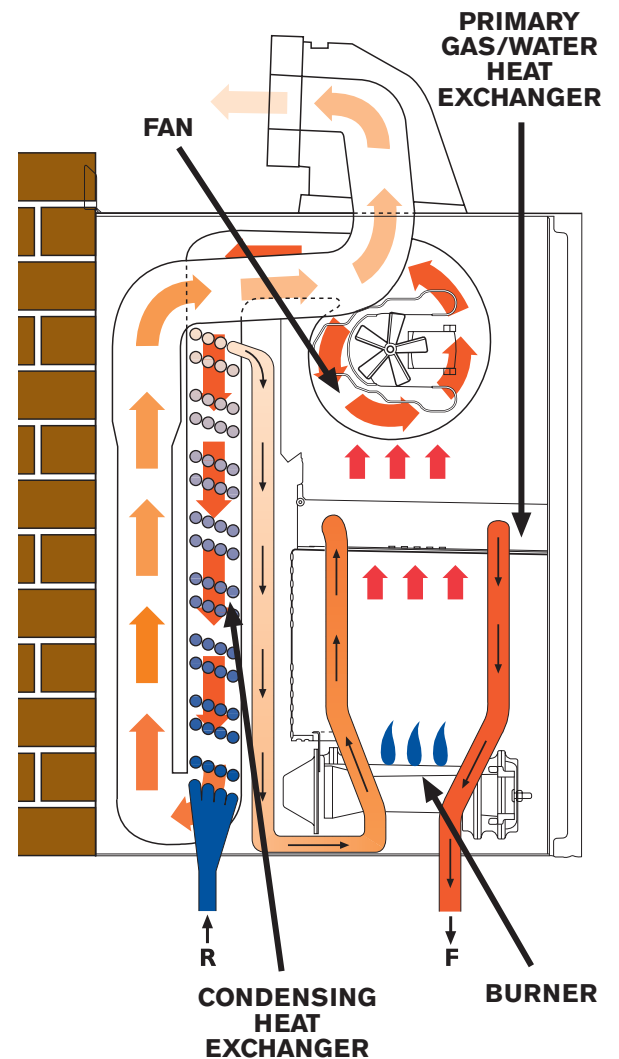
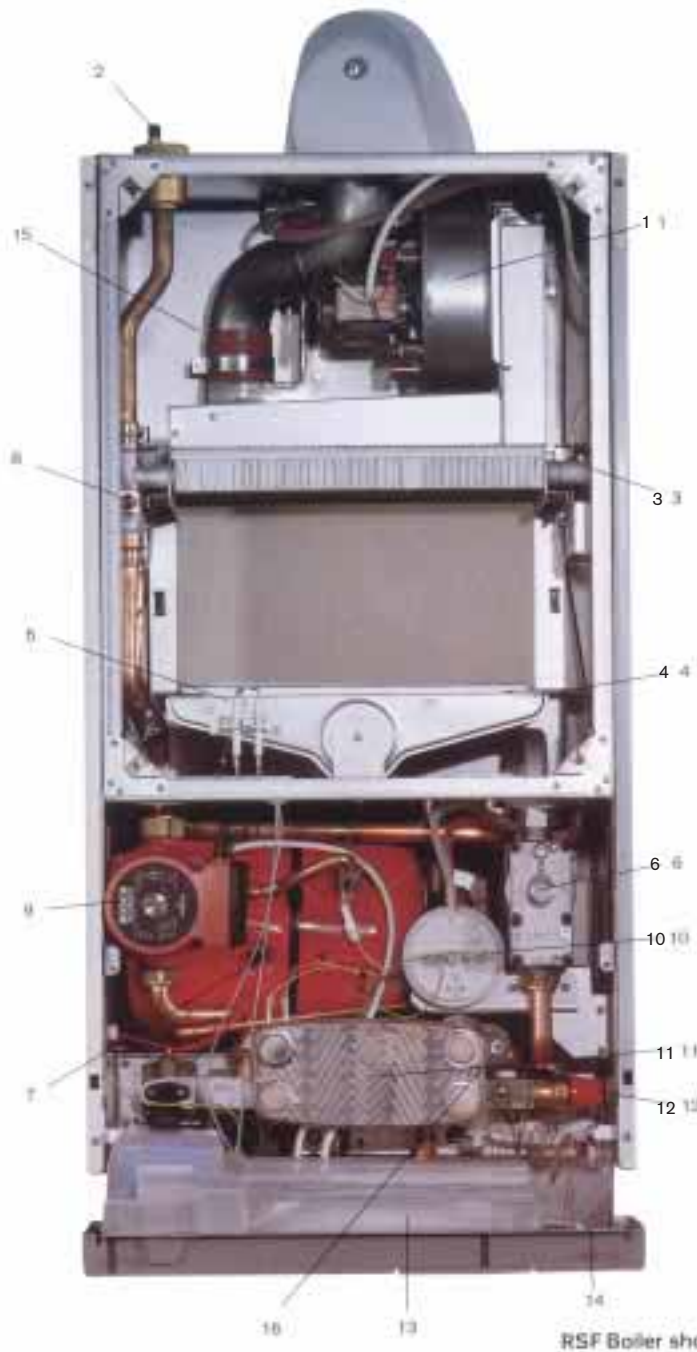

Key to components

- | | | |
|---|-----------------------------------|--|
| 1. Combustion Air Fan (2 speed) | 7. Primary Expansion Vessel | 13. Bosch Heatronic Series Control Board |
| 2. Automatic Air Vent | 8. CH Temperature Sensor | 14. Pressure Gauge |
| 3. Low Water Content Primary Heat Exchanger | 9. Circulating Pump | 15. Secondary Condensing Heat Exchanger Outlet |
| 4. Gas Burner | 10. Air Pressure Switch | 16. Syphonic Condensate Trap |
| 5. Direct Burner Ignition Electrodes | 11. Water to Water Heat Exchanger | |
| 6. Fully Modulating Automatic Bosch Gas Valve | 12. Pressure Relief Valve | |

Installing the 26CDi XTRA combi

All Combi boilers require less installation time than a conventional boiler, for these reasons:

1. All the major components, including the pump, are contained within the boiler casing and do not need to be fitted separately.
2. The boiler comes pre-wired and pre-plumbed.
3. There is no need to install a hot water cylinder.
4. There is no need to install a storage tank in the roof space.
5. There is less pipework.

However, the Worcester Bosch 26CDi XTRA is exceptional for its number of additional time-saving installation features:

- New wall-mounting jig is much quicker and easier, and reduces the risk of damaging the wall
- Built-in bypass
- Built-in filling loop
- Built-in frost thermostat
- Built-in fault-finding diagnostics
- Automatic gas pressure adjustment
- No scale inhibitor required
- Highly versatile multi-directional fluing system
- Combined ignition and control board means less connections
- Plug-in mechanical and digital timers means no electrician is required
- Plug-in component technology for quick parts replacement

Siting of appliance

General

The appliance is not suitable for external installation.

The wall on which the boiler is to be mounted should be capable of supporting an overall weight of approximately 50kg.

The wall does not require special protection, however, if the appliance is to be fitted in a timber frame building the guidelines laid down in BS 5440:Part 1:1990 should be adhered to.

The appliance may be installed into an airing cupboard if required. See section "Air supply:"

Clearances

The following clearances should be allowed for installation and servicing.

| Position on Appliance | Dimensions |
|-----------------------------|------------|
| In front | 600mm |
| Below | 200mm |
| Right side | 10mm |
| Left side | 10mm |
| Above the Flue Elbow/Casing | 30mm |

Pipework connections & casing dimensions

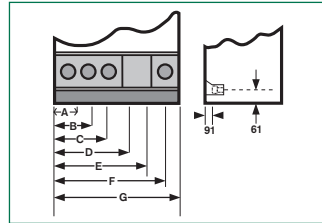

26CDi XTRA Pipework connections

| | | |
|---|---------------------|---------|
| A | CH Flow | 62.5mm |
| B | DHW Out | 127.5mm |
| C | Mains Cold Water In | 192.5mm |
| D | Gas Inlet | 257.5mm |
| E | CH Return | 322.5mm |
| F | Safety Relief | 382.5mm |
| G | Condensate | 405mm |

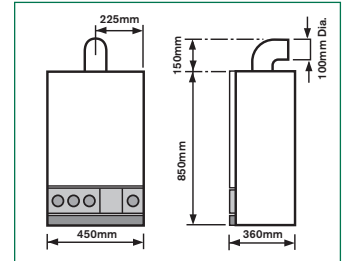

26CDi XTRA RSF cabinet dimensions

| | | |
|--------|-------|-------|
| Height | Width | Depth |
| 850mm | 450mm | 360mm |

Wall preparation/portability

The diagram shows the new 26CDi XTRA wall-mounting jig, which is designed to make installation easier and to reduce the possibility of wall damage. The jig and manifold assembly enable all gas and water services to be pre-plumbed and tested prior to hanging the boiler.

A wall spacing frame is available as an optional extra. This spaces the boiler a further 30mm off the wall, enabling the pipework to be passed behind. The plug-in bayonet fittings allow the appliance to be simply removed thus offering true portability, particularly suitable for leasing schemes.



Condensate disposal

The condensate drain connection is located at the bottom right hand side of the appliance.

The 22mm plastic discharge pipe should discharge into the household drainage system and have an internal termination. If this is not practical, discharge into an outside gully or soak away is acceptable.

The condensate discharge pipe should have a fall of 2.5° (44mm per metre length). It is not necessary to provide air breaks or traps in the discharge pipe. The appliance includes an integral 75mm trap and syphon.

An externally installed condensate drain pipe should ideally be insulated to prevent it from freezing. Alternatively, a large diameter pipe can be used and insulated.

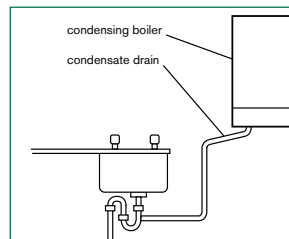

The condensate pipe from the boiler is run to a kitchen sink or washing machine drain pipe. It can also be run to an internal stack.

Flue terminal positioning

RSF horizontal and vertical

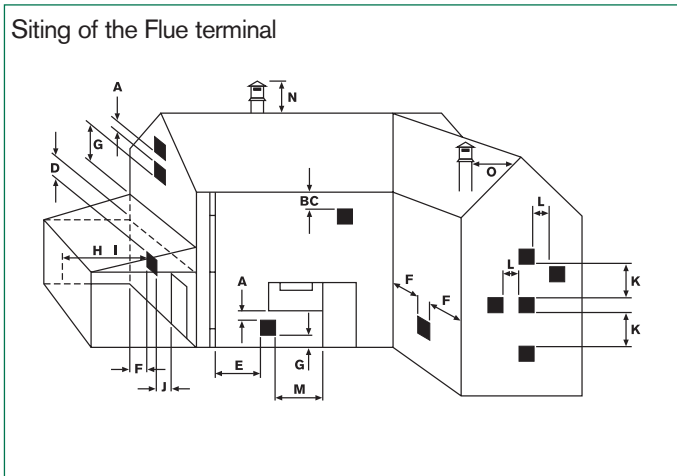

The flue system must be installed and terminated in accordance with the recommendations of BS 5440: Part 1.

General Position

1. The terminal must not cause an obstruction nor the discharge a nuisance.
2. If the terminal is fitted within 1000mm of a plastic or painted gutter or within 500mm of painted eaves, then an aluminium shield at least 750mm long should be fitted to the underside of the gutter or painted surface.
3. If a terminal is fitted less than 2 metres above a surface to which people have access, then a guard must be fitted. A terminal protective guard is available from Tower Flue Components, Vale Rise, Tonbridge. Tel No. (01732) 351555. RSF terminal guard GC No. 393553.

The terminal guard must be securely fixed to the wall using suitable plugs and corrosion resistance screws. The guard must be symmetrically positioned about the terminal assembly and spaced

such that there is a gap of 50mm between the end of the terminal and the guard.

4. A white plume of condensation will be emitted from the flue terminal, siting where this could cause a nuisance i.e. near security lighting, should be avoided.
5. The air inlet/outlet duct and the terminal of the boiler must not be closer than 25mm to any combustible material. Detailed recommendations on protection of combustible materials are given in BS 5440:1.

| Terminal Position | Min Distance |
|---|-----------------|
| A Directly below an openable window or other opening eg air brick | 300mm |
| B Below gutters, soil pipes or drain | 75mm |
| C Below eaves | 200mm (8 in) |
| D Below balconies or car port roof | not recommended |
| E From vertical drain pipes and soil pipes | 75mm |
| F From internal or external corners | 300mm (12 in) |
| G Above ground, roof or balcony level | 300mm |
| H From a surface facing a terminal | 1200mm |
| I From a terminal facing a terminal | 1200mm |
| J From an opening in a car port into a dwelling | not recommended |
| K Vertically from a terminal on the same wall | 1500mm |
| L Horizontally from a terminal on the same wall | 300mm |
| M From door, window, or air vent (achieve where possible) | 150mm |
| N Minimum protrusion through roof space | 300mm |
| O From vertical wall or obstruction | 500mm |

Fluing options

The appliance may be installed in any room, although particular attention is drawn to the requirements of the IEE regulations applicable and in Scotland the electrical provisions with respect to installation in a room containing a bath or shower.

Air supply

1. The room in which the appliance is installed does not require a purpose provided air vent.
2. If the appliance is installed in a cupboard or compartment with dimensions that allow the following clearances, then no ventilation is required:

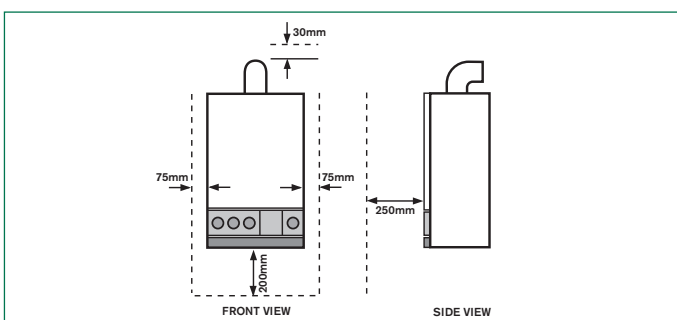

Should the appliance be installed in a cabinet that does not permit these dimensions then the ventilation requirements listed in the table below should be adhered to.

| | Position Vents | Air from Room | Air from Outside |
|-------------------|-------------------------|--|--|
| 26kW CDi XTRA RSF | High level Low level | 270cm ² (106in ²) 270cm ² (106in ²) | 135cm ² (53in ²) 135cm ² (53in ²) |

26CDi XTRA horizontal RSF flue

| | |
|---------------------|--------|
| Flue Diameter | 100mm |
| Minimum Flue Length | 100mm |
| Maximum Flue Length | 2000mm |

Standard flue kit

Comprises: 1 x Flue Turret Elbow
1000mm
(as measured
from side panel) } Part No. 7 716 191 059

Accessories

Extended Flue Kit 2000mm long Part No. 7 716 191 060

The following criteria should be noted when planning the installation.

- Maximum straight flue length permissible is 2 metres, including the flue turret fitted to the top of the boiler.
- The flue system inclines 2.5° (44mm per metre) towards the appliance, to prevent condensation from dripping from the flue terminal.
- Because the appliance operates at high efficiency a white plume of condensation will be emitted from the terminal. Care must be taken when selecting the flue terminal position.

Option 1 STANDARD HORIZONTAL FLUE ASSEMBLY

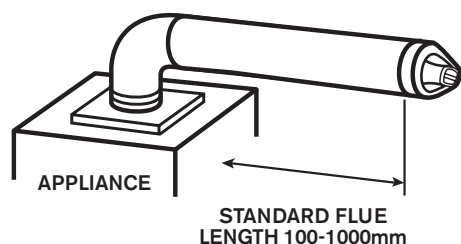

Flue Components Required

| Quantity | Worcester Bosch Part No. | Description |
|----------|--------------------------|-------------------|
| 1 | 7 716 191 059 | Standard Flue Kit |

Option 2 EXTENSION FLUE HORIZONTAL

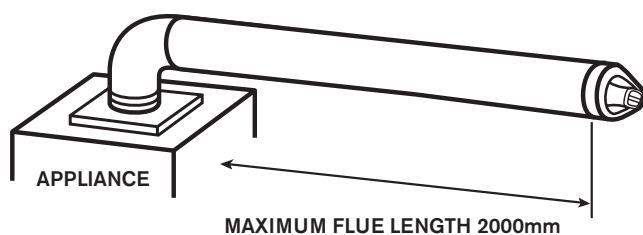

Flue Components Required

| Quantity | Worcester Bosch Part No. | Description |
|----------|--------------------------|-------------------|
| 1 | 7 716 191 060 | Extended Flue Kit |

26CDi XTRA vertical RSF flue

Vertical flue kit

Comprises: 1 x Flue Terminal
Assembly
1 x Vertical Flue
Adaptor
1 x Firestop Spacer } Part No. 7 716 191 070

Accessories

Extension Flue Kit Part No. 7 716 191 071

Option 1 STANDARD VERTICAL FLUE ASSEMBLY

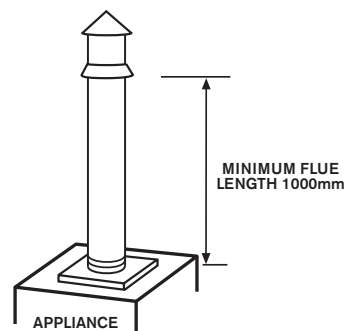

Flue Components Required

| Quantity | Worcester Bosch Part No. | Description |
|----------|--------------------------|-------------------|
| 1 | 7 716 191 070 | Vertical Flue Kit |

Option 2 EXTENSION FLUE VERTICAL

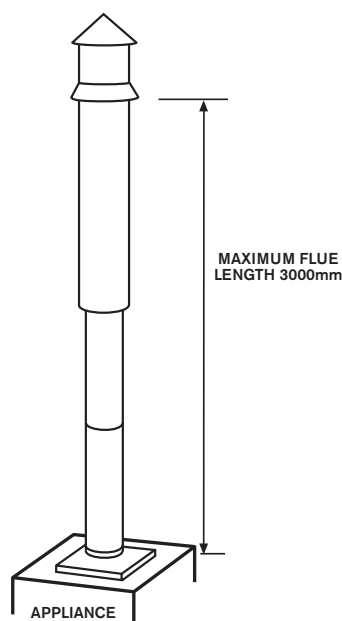

Flue Components Required

| Quantity | Worcester Bosch Part No. | Description |
|----------|--------------------------|-------------------|
| 1 | 7 716 191 070 | Vertical Flue Kit |
| 2 | 7 716 191 071 | Extended Flue Kit |

Installation requirements

Installation of the 26CDi XTRA must be in accordance with the relevant requirements of the Gas Safety (Installation Use) Regulations 1994 (as amended), current IEE Wiring Regulations, local Building Regulations, Building Standards (Scotland) (Consolidation) and bylaws of the local Water company and Health and Safety Document No. 635 (Electricity at Work Regulations 1989). It should be in accordance with the relevant recommendations of the following British Standards:

BS 6798:1987; BS 5449:1990; BS 5546:1:1990; BS 5440:1:1990; BS 5440:2:1989; BS 6891:1988.

Gas Safety (Installation and Use) Regulations 1984. All gas appliances must be installed by a Corgi registered person in accordance with the above regulations. Failure to install appliances correctly could lead to prosecution.

The manufacturers notes must not be taken in any way as overriding statutory regulations.

Sealed primary systems

The Worcester Bosch 26CDi XTRA is supplied complete with all the necessary components to form a sealed primary system. Included are a pre-plumbed expansion vessel (8 litres), a pressure relief valve (set at 3bar), an automatic air vent and a pressure gauge.

With an initial system pressure of 0.5 bar a system capacity of approximately 83 litres can be accommodated. Refer to BS 7074:Part 1 for more information. The charge pressure can be increased by with a decrease in system volume.

System filling and make-up

The Worcester Bosch 26CDi XTRA incorporates a purpose designed built-in filling loop. The patented link incorporates an isolating valve, double check valve assembly and push fit filling link that all comply with Bylaw 14 of the Water Bylaws.

Valves and joints

It is very important that all valves and joints are able to sustain a working pressure of up to 3bar (45psi). Particular care should be exercised when fitting radiator valves and only those of high quality to BS 2767:10 should be used. All other valves and fittings should comply with BS 1010.

Loss of water pressure from a sealed system will require continuous recharging with fresh water and consequential introduction of air. Air is highly corrosive and will considerably reduce life expectancy of radiators, pumps etc.

Open vented primary systems

The 26CDi XTRA is not suitable for connection to an open vented primary system.

Natural gas supply

The appliance when on a hot water demand will require 2.7m³/hr (96ft³/hr) of gas. The gas meter and supply pipes must be capable of supplying this quantity of gas in addition to the demand from any other appliance being served. It is important that a gas supply pipe of at least 22mm diameter is used. Under no circumstances should the size of the gas supply pipe be less than that of the appliance inlet connection. The meter outlet governor should be capable of ensuring a dynamic pressure of 20mbar (8in wg) at the appliance. Particular consideration should be given to the resistance to gas flow created by elbows, bends etc. Pipework should be sized to overcome this resistance, details of this are given in the table below.

| Gas Discharge Rate m ³ /h | Total length of Gas Supply Pipe (metres) | | | Pipe Diameter (mm) |
|--------------------------------------|--|-----|---|--------------------|
| | 3 | 6 | 9 | |
| 2.9 | - | - | - | 15 |
| 8.7 | 5.8 | 4.6 | - | 22 |
| 18.0 | 12.0 | 9.4 | - | 28 |

Approximate Additional Length to be Allowed (Natural gas)

| Elbows or Tees | | 90° Bends | |
|----------------|------|-----------|------|
| Metres | Feet | Metres | Feet |
| 0.5 | 2 | 0.3 | 1 |

Propane gas supply

The 26CDi XTRA is available in a propane gas version. The appliance when on a hot demand will require 1.0m³/hr (35ft³/hr) of gas. The gas tank or bottles must be capable of supplying this quantity of gas at a nominal pressure of 37mbar (14.8in wg) at the appliance. The table below shows the propane gas discharge through varying lengths of pipe and the resistance to flow created by elbows, bends etc. Pipework should be sized so as to overcome this resistance.

| Gas Discharge Rate m ³ /h | Total length of Gas Supply Pipe (metres) | | | Pipe Diameter (mm) |
|--------------------------------------|--|-----|---|--------------------|
| | 3 | 6 | 9 | |
| 1.49 | .08 | - | - | 15 |
| 8.0 | 5.2 | 4.2 | - | 22 |
| 15.9 | 8.8 | 8.3 | - | 28 |

Installation requirements

Approximate Additional Length to be Allowed (LPG)

| Elbows or Tees | | 90° Bends | |
|----------------|------|-----------|------|
| Metres | Feet | Metres | Feet |
| 0.6 | 2 | 0.3 | 1 |

Therefore, in order to avoid excessive starvation of flow to individual taps, flow balancing may be required by the use of proprietary constant volume flow regulators or Ball-o-Fix valves.

Hot water systems

Taps and valves

Hot and cold taps and mixing valves used with the 26CDi XTRA appliance must be suitable for operating at a mains pressure and temperatures of 65°C (150°F).

Showers

When a loose head shower with a flexible hose is used over a bath or shower tray, the hose must be fixed so that the head cannot fall closer than 25mm (1in) above the top edge of the spill over level of the relevant bath or shower tray. Alternatively, the feed pipes to the shower should incorporate a double check valve assembly or a check valve and vacuum breaker.

With fixed head showers no provision is necessary.

The use of a thermostatically controlled shower will give added comfort and safeguard against high hot water temperatures. Alternatively, a pressure balancing shower valve specifically designed for constant temperature water heaters would be suitable.

Bidet

The supply of hot and cold water mains direct to a bidet is permitted provided that the bidet is of the overrim water feed type. The outlet(s) should be shrouded and not to have any temporary hand held spray attached. No other anti-syphonage arrangements are necessary.

Use in hard water areas

As the maximum temperature of the domestic hot water heat exchanger is limited by the electronic control circuit, there is normally no need for water treatment to prevent scale accumulation.

In areas where exceptional water conditions prevail, consideration may need to be given to the fitting of a device capable of preventing scale. In such circumstances the advice of the local water authority should be sought.

Warranty

Worcester Bosch appliances are offered with a full year's guarantee on parts and labour. Ongoing service may be arranged through the Worcester Bosch Customer Service Department.

Electricity supply

A 3 amp fused three pin plug and unswitched shuttered socket outlet (both complying with BS 1363) or preferably a double pole isolator with a contact separation of 3mm in all poles supplying the appliance should be used.

The appliance electrical circuits are also protected by an internal 2 amp fuse. The appliance must be earthed.

Mains cold water supply

Water Authority requirement

A direct mains cold water connection is permitted by Water Authorities, however, it is recommended that reference be made to local requirements. In the event of difficulty contact Worcester Heat Systems Technical Department.

Pipe sizing

Unless the mains pressure is low, a standard 15mm diameter service pipe is normally suitable. A 15mm hot water distribution pipe to the first branch is recommended thereafter 15mm and/or 10mm to all draw off points.

Cold Water connection

Connection should be made as shown in the pipework detail and the appliance installed generally in accordance with the layout shown on page 7.

Wherever possible the cold supply to the appliance should be the first connection off the mains supply, in order to minimise hot water flow reduction when cold water services are operated. The final 600mm of piping to the appliance should be of copper only.

Cold water pressure

To achieve the stipulated flow rate a working cold water mains pressure of 1.2bar (17.6psi) is required. The appliance will operate at a minimum working pressure of only 0.7bar (10psi) however a reduced hot water flow rate should be expected.

Hot water supply

A domestic hot water flow regulator, set to give an optimum flow rate of 9lts/min (2.0gpm) + or - 15% is fitted to the cold supply of the hot water heat exchanger.

As with all mains fed systems, the flow rate of water obtainable from individual taps will vary in relation to the number of taps operating simultaneously, and will depend upon the cold mains supply available to the property.

The 26CDi XTRA accessories

MECHANICAL TIMECLOCK



Worcester Bosch Part No. 7 716 192 002

ELECTRONIC PROGRAMMER



Worcester Bosch Part No. 7 716 192 003

DIGISTAT RADIO FREQUENCY CONTROLLED ROOM THERMOSTAT



Worcester Bosch Part No. 7 716 192 006

PRE-SYSTEM FILLING KIT



Worcester Bosch Part No. 7 716 192 102

WALL SPACING FRAME

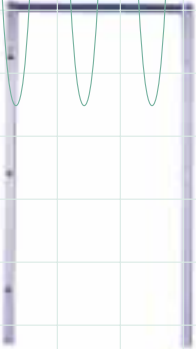

Worcester Bosch Part No. 7 716 192 111

ANTI-THEFT SECURITY NUTS & BOLTS



Worcester Bosch Part No. 7 716 192 112

KICK STRIP

Your livery here



TRANSPONDER

Property of
Sunderland Council



5 020974 041859

TEL: 01905 754624

The very best training programmes from Worcester Bosch

Worcester Heat Systems have always placed great emphasis on support and training for installers and service engineers. Today this need is greater than ever: one in every four boilers now purchased in the UK is a combi boiler and, as already described in the preceding pages, the differences between a combi and a conventional boiler are substantial, and the technology of both continues to advance at a rapid pace.

To ensure the highest levels of competence and expertise in the installation of all Worcester Bosch boilers, the company runs intensive training courses for installers, commissioning engineers and engineers involved with servicing and fault finding.

Worcester Bosch Training Centres

Worcester Bosch can offer training courses at one of 5 purpose built training centres located at Worcester, Clay Cross (Derbyshire), Mildenhall (East Anglia), Rochester (Kent) and Livingston (Scotland). Each centre is equipped with working models of the gas combis within the range, all of which can be serviced, commissioned etc, enabling a true "hands-on" practical element to be introduced to the courses.



Courses available

The Worcester Bosch Training Department have on offer a number of courses suitable for the installer and commissioning engineers, and a more in-depth course for the servicing and fault finding engineers.

Details of courses are available from:

The Training Services Administrator,
Worcester Heat Systems Ltd,
Cotswold Way, Warndon, Worcester WR4 9SW.
Tel: (01905) 752526

In addition to this very comprehensive training programme, Worcester Bosch offers technical support and advice to installers and engineers in the field.



A complete after-sales service – whenever you need it

As part of the worldwide Bosch Group, Worcester Heat Systems is duty bound to maintain the highest possible standards of after-sales care.

In addition to the no-nonsense parts and labour warranty applicable to all Worcester Bosch boilers, you and your customers have the assurance that every Worcester Bosch boiler is manufactured to the appropriate British and European Standards.

What's more, at the company's new multi-million pound headquarters, you have access to Worcester Bosch's comprehensive after-sales service and technical advice unit which provides technical advice on all aspects of the company's extensive product range.

This includes help in selecting a boiler or system to suit a particular



application, along with full guidance on installation. So, wherever you are, Worcester Bosch's support team is behind you all the way.

And the same goes for Spares. Replacement parts for all Worcester Bosch boilers are readily available from stock, on a next day delivery basis, enabling you to deal promptly and efficiently with your customers.



All the technical advice you need



Post-sales technical team.

The Worcester Bosch Technical Helpline is a dedicated phone line – dedicated to providing the best service from any manufacturer in the industry. Our team of technical experts provide the answers to queries of a technical nature on any product in the Worcester Bosch range, from application to installation to performance



Pre-sales technical team.

Full range of Worcester Bosch Gas Combination Boilers

| APPLIANCE | | OPTIONS | | | Heating Output | Hot Water Flow Rates @ 40°C & 35°C rise | Cabinet Dimensions H x W x D | Flue Lengths Standard | Extended Flue Option | |
|----------------|------------------|--------------------|--------------------|-------------------------------------|--|---|--|-----------------------|---------------------------|---------------|
| | | Programmer | Sealed System | LPG | | | | | | |
| GAS FIRED | WALL HUNG | 24i | ✓ | Standard | ✓ | 7.5 - 23.4kW 25,600 - 80,000 Btu/h | 8.4lts/min (1.8gpm) Δ 40°C rise 9.5lts/min (2.1gpm) Δ 35°C rise | 800 x 450 x 360 | 200 - 500mm (8 - 19.6ins) | 2.5m (98ins) |
| | | 28i | ✓ | Standard | - | 10.5 - 27.5kW 25,600 - 93,800 Btu/h | 9.8lts/min (2.2gpm) Δ 40°C rise 11.4lts/min (2.5gpm) Δ 35°C rise | | | |
| | | 25Si | ✓ | Standard | ✓ | 8.5 - 25kW 29,000 - 85,300 Btu/hr | 9.0lts/min (2.0gpm) Δ 40°C rise 10.2lts/min (2.2gpm) Δ 35°C rise | 800 x 440 x 360 | 200 - 500mm (8 - 19.6ins) | 3m (117.9ins) |
| | | 28Si | ✓ | Standard | ✓ | 8.5 - 28kW 29,000 - 95,500 Btu/hr | 10.0lts/min (2.2gpm) Δ 40°C rise 11.4lts/min (2.5gpm) Δ 35°C rise | | | |
| | | 24CDi RSF | ✓ | Standard | ✓ | 9.0 - 24kW 30,700 - 82,000 Btu/hr | 8.6lts/min (1.9gpm) Δ 40°C rise | 850 x 450 x 360 | 650mm (25ins) | 4m (157ins) |
| | | 24CDi BF | ✓ | Standard | - | | | 850 x 450 x 360 | 420mm (16.5ins) | 559mm (22ins) |
| | | 24CDi OF | ✓ | Standard | ✓ | | | 850 x 450 x 360 | | |
| | | | | | Optional Open Vent | | 9.5lts/min (2.1gpm) Δ 35°C rise | | | |
| | | 26CDi XTRA | ✓ | Standard | ✓ | 6.7 - 26kW 22,860 - 88,700 Btu/hr | 8.6lts/min (1.9gpm) Δ 40°C rise 9.5lts/min (2.1gpm) Δ 35°C rise | 850 x 450 x 360 | 1000mm (39.3ins) | 2m (78.7ins) |
| | | 28CDi | ✓ | Standard | ✓ | 9.0 - 24kW 30,700 - 82,000 Btu/hr | 10lts/min (2.2gpm) Δ 40°C rise | 850 x 450 x 360 | 650mm (25ins) | 3m (117.9ins) |
| | | Optional Open Vent | | 11.4lts/min (2.5gpm) Δ 35°C rise | | | | | | |
| 35CDi | ✓ | Standard | ✓ | 9 - 25kW 30,700 - 85,000 Btu/hr | 12.7lts/min (2.8gpm) Δ 40°C rise 14.3lts/min (3.2gpm) Δ 35°C rise | 900 x 500 x 310 | 1m (39.3ins) | 2m (78.7ins) | | |
| FLOOR STANDING | Highflow 400 OF | ✓ | Standard | ✓ | 8.8 - 24kW 30,000 - 82,000 Btu/hr | 18lts/min (4.0gpm) | 860 x 600 x 600 | - | - | |
| | Highflow 400 BF | ✓ | Standard | ✓ | | | 860 x 600 x 600 | 406mm (16ins) | 560mm (22ins) | |
| | Highflow 400 RSF | ✓ | Standard | ✓ | | | 860 x 600 x 600 | 1m (39.3ins) | 3m | |
| | | | Optional Open Vent | | | | | | | |

NOTES: ✓ = Available - = Not Available

Useful numbers

Sales

Tel: 01905 752640

Fax: 01905 456445/455394

Technical

Tel: 08705 266241

Fax: 01905 757224

Spares

Tel: 01905 752576

Fax: 01905 754620

Service

Tel: 008457 256206

Fax: 01905 754701

Training

Tel: 01905 752526

Fax: 01905 754601



Worcester Heat Systems Ltd.
(Bosch Group)
Cotswold Way
Warndon
Worcester, WR4 9SW

Tel: 01905 754624

Fax: 01905 754619

Web: www.worcester-bosch.co.uk

This leaflet is accurate at the date of printing, but may be superseded and should be disregarded if specification and/or appearances are changed in the interest of continued improvement. The statutory rights of the consumer are not affected.