

INSTALLER GUIDE

Model 741FS Heat Engine

(GC No. 32-032-56)

INSET LIVE FUEL EFFECT GAS FIRE
INCORPORATING THE **FireSlide** CONTROL



**THIS APPLIANCE IS FOR USE WITH NATURAL GAS (G20).
WHEN CONVERTED USING CONVERSION KIT NO. 0595211 THIS
APPLIANCE IS FOR USE WITH PROPANE GAS (G31).
THIS APPLIANCE IS SUITABLE ONLY FOR INSTALLATION IN THE UNITED
KINGDOM (GB) AND THE REPUBLIC OF IRELAND (IE).**

We trust that this guide gives sufficient details to enable this appliance to be installed and maintained satisfactorily. However, if further information is required **please telephone 01302 349 231 .**

INSTALLER: Please leave this guide with the owner

INSTALLER GUIDE

Safety First.

This gas fire is CE Approved and designed to meet the appropriate British Standards and Safety Marks.



Quality and Excellence.

This fire has been manufactured to the highest standards of quality and excellence and was manufactured under a BS EN ISO 9001 quality system accepted by the British Standards Institute.



The Highest Standards

The manufacturer is a member of the Society of British Gas Industries which works to ensure high standards of safety, quality and performance.



Careful Installation

The manufacturer is a CORGI registered company. This gas fire must be installed by a competent CORGI Registered Installer in accordance with our Installer Guide and should not be fitted directly on to a carpet.

Baxi Fires Division, Erdington, Birmingham B24 9QP

Because our policy is one of constant development and improvement, details may vary slightly from those given in this publication

INSTALLER GUIDE

CONTENTS

<u>Section</u>	<u>Heading</u>	<u>Page</u>
1.	SAFETY	4
2.	APPLIANCE DATA	4
3.	GENERAL INSTALLATION REQUIREMENTS	5
4.	PACK CONTENTS	12
5.	FIREPLACE CHECK	13
6.	IGNITION CHECK	15
7.	GAS SUPPLY CONNECTION	15
8.	PREPARING APPLIANCE FOR INSTALLATION	16
9.	HOTBOX INSTALLATION	18
	9.1 Method 1 - Front fixing to fireplace surround.	18
	9.2 Method 2 - Cable retention and floor fixing.	19
	9.3 Sealing floor front - All installations.	21
10.	BURNER & SUPPLY PIPE INSTALLATION	22
11.	CERAMIC WALLS INSTALLATION	23
12.	FITTING THE FASCIA	24
13.	FITTING THE CERAMIC FUEL EFFECT	24
14.	FULL OPERATING CHECKS	24
15.	FINAL REVIEW	27
16.	SERVICING & PARTS REPLACEMENT	28
	16.1 Checking the aeration setting of the burner.	29
	16.2 To remove the ignition microswitch.	29
	16.3 To remove the gas shut-off microswitch.	29
	16.4 To remove the fascia.	30
	16.5 To replace the control slide unit.	30
	16.6 To replace the control slide button.	30
	16.7 To remove the burner unit.	31
	16.8 To remove the electronic ignition generator.	31
	16.9 To remove the thermocouple interrupter block.	32
	16.10 To remove the pilot unit.	32
	16.11 To remove the shut-off tap.	32
	16.12 To remove the gas flow rate controller .	33
	16.13 To replace the burner.	34
	16.14 To remove the main burner injector	34
	16.15 To remove the appliance from the fireplace.	34

INSTALLER GUIDE

1. SAFETY

Installer

Before continuing any further with the installation of this appliance please read the following guide to manual handling:

- The lifting weight of this heat engine and burner assembly is 8.5kg.
- One person should be sufficient to lift the fire. If for any reason this weight is considered too heavy then obtain assistance.
- When lifting always keep your back straight. Bend your legs and not your back.
- Avoid twisting at the waist. It is better to reposition your feet.
- Avoid upper body/top heavy bending. Do not lean forward or sideways whilst handling the fire.
- Always grip with the palm of the hand. Do not use the tips of fingers for support.
- Always keep the fire as close to the body as possible. This will minimise the cantilever action.
- Use gloves to provide additional grip.
- Always use assistance if required.

2. APPLIANCE DATA

This product uses fuel effect pieces and burner compartment walls containing Refractory Ceramic Fibres (RCF), which are man-made vitreous silicate fibres. Excessive exposure to these materials may cause irritation to eyes, skin and respiratory tract. Consequently, it is important to take care when handling these articles to ensure that the release of dust is kept to a minimum. To ensure that the release of fibres from these RCF articles is kept to a minimum, during installation and servicing we recommend that you use a HEPA filtered vacuum to remove any dust and soot accumulated in and around the fire before and after working on the fire. When replacing these articles we recommend that the replaced items are not broken up, but are sealed within a heavy duty polythene bag, clearly labelled as RCF waste. This is not classified as “hazardous waste” and may be disposed of at a tipping site licensed for the disposal of industrial waste. Protective clothing is not required when handling these articles, but we recommend you follow the normal hygiene rules of not smoking, eating or drinking in the work area and always wash your hands before eating or drinking. This appliance does not contain any component manufactured from asbestos or asbestos related products.

INSTALLER GUIDE

Gas	Natural (G20)	Propane (G31) *
Inlet Pressure	20mbar	37mbar
Input - Max. (Gross)	6.85kW (23,400 Btu/h)	6.7kW (22,860 Btu/h)
Input - Min. (Gross)	2.7kW (9,410 Btu/h)	4.3kW (14,670 Btu/h)
Inlet Test Pressure (Cold)	20.0 ± 1.0mbar (8.0 ± 0.4in w.g.)	37.0 ± 1.0 mbar (14.85 ± 0.4in w.g.)
Gas Connection	8mm pipe	8mm pipe
Burner Injector	Stereomatic Cat 82 - 074	Stereomatic Size 132
Pilot & Atmosphere Sensing Device	Copreci Ref. O.D.S 21500/166	Copreci Ref. O.D.S 21500/166 Fitted with RBM 180 -02 injector
Ignition	Electronic (Battery 9V PP3)	Electronic (Battery 9V PP3)
Aeration	See section 16.1	Non-adjustable

*When converted using kit 0595211.

The appliance data label is located on a 'pivot' plate at the base of the fire. This can be seen by pulling on the raised tab.

3. GENERAL INSTALLATION REQUIREMENTS

3.1 The installation must be in accordance with these instructions.

For the user's protection, in the United Kingdom it is the law that all gas appliances are installed by competent persons in accordance with the current edition of the Gas Safety (Installation and Use) Regulations. Failure to install the appliance correctly could lead to prosecution. The Council for the Registration of Gas Installers (CORGI) requires its members to work to recognised standards.

In the United Kingdom the installation must also be in accordance with:

All the relevant parts of local regulations.

All relevant codes of practice.

The relevant parts of the current editions of the following British Standards:-

BS 715	BS 1251	BS 1289 Part 1	BS 1289 Part 2
BS EN 1806	BS 4543 Part 2	BS 5440 Part 1	BS 5440 Part 2
BS 5871 Part 2	BS 6461 Part 1	BS 6891	BS 8303

In England and Wales, the current edition of the Building Regulations issued by the Department of the Environment and the Welsh Office

INSTALLER GUIDE

In Scotland, the current edition of the Building Standards (Scotland) Regulations issued by the Scottish Executive.

In Northern Ireland, the current edition of the Building regulations (Northern Ireland) issued by the Department of the Environment for Northern Ireland.

In the republic of Ireland the installation must be carried out by a competent person and also conform to the relevant parts of:

- a) The current edition of IS 813 “Domestic Gas Installations”
- b) All relevant national and local rules in force.

Where no specific instructions are given, reference should be made to the relevant British Standard Code of Practice.

3.2 In the United Kingdom, as supplied, the appliance can be installed in the following situations: -

3.2.1 To a fireplace complete with surround and hearth as shown in figure 1 and complying with BS1251 after removal of the fireback and sufficient material behind the fireback for a debris catchment space. The required fireplace, hearth, debris catchment area and clearance dimensions are shown in figure 1.

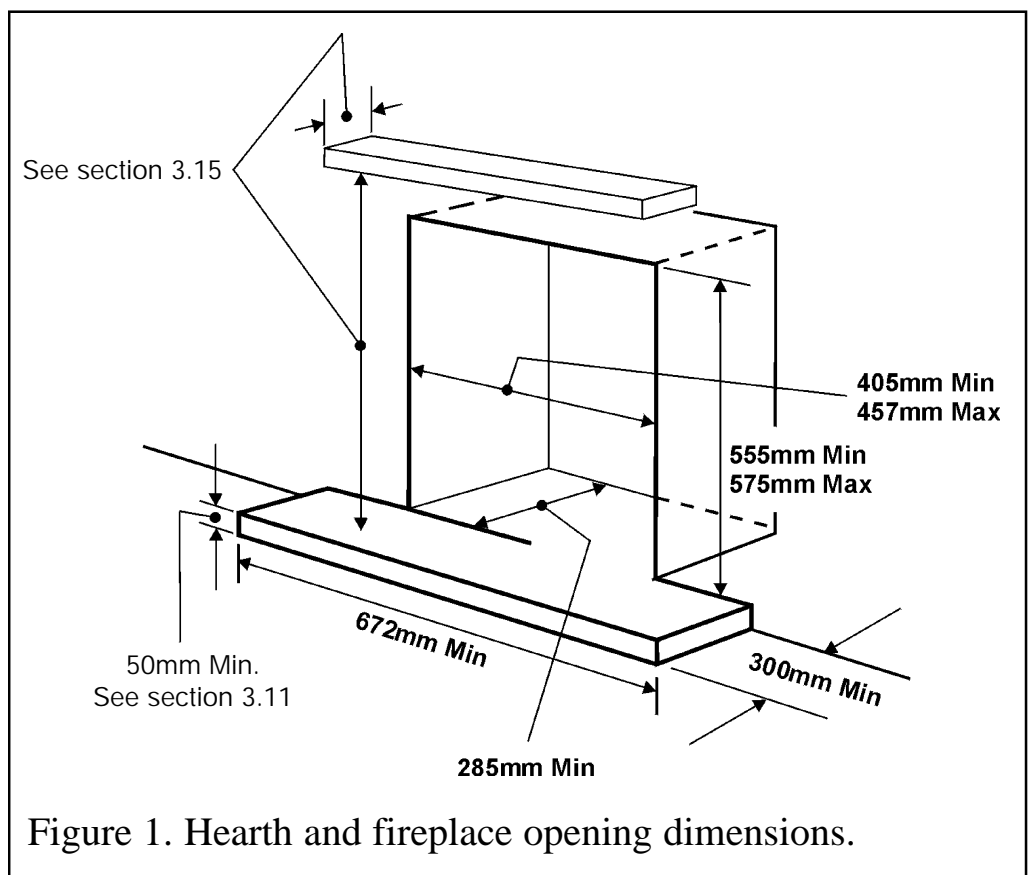

Figure 1. Hearth and fireplace opening dimensions.

3.2.1.1 ‘Hole-in-the-wall’ installations

- It is recommended that a hearth should be installed as in figure 1.
- If a reduced depth hearth is fitted, the fire must be installed so that the distance from the base of the fireplace opening in the wall to the finished floor level is at least 100 mm. It is recommended that the reduced hearth has a depth from the fixing plane of the fire of 100mm minimum. This is necessary to support the lower front casting. The minimum shelf height will have to be taken from the base of the fireplace opening.

3.2.2 To a fireplace incorporating a metal flue box complying with the constructional requirements of the current edition of BS715. The dimensions of the flue box must conform to those shown in figure 2.

INSTALLER GUIDE

3.2.3 To a precast concrete or clay flue block system conforming to BS1289 with dimensions as in figure 3. The current versions of BS1289 and BS EN 1806 recommend that there should be an air space or insulation between the flue blocks and the plaster because heat transfer may cause cracking on directly plastered flues. However, generally this appliance is suitable for installations under all circumstances unless there is a history of cracking problems. Remember that faults such as cracking may be caused by poorly built and restrictive flues, e.g. mortar extrusions, too

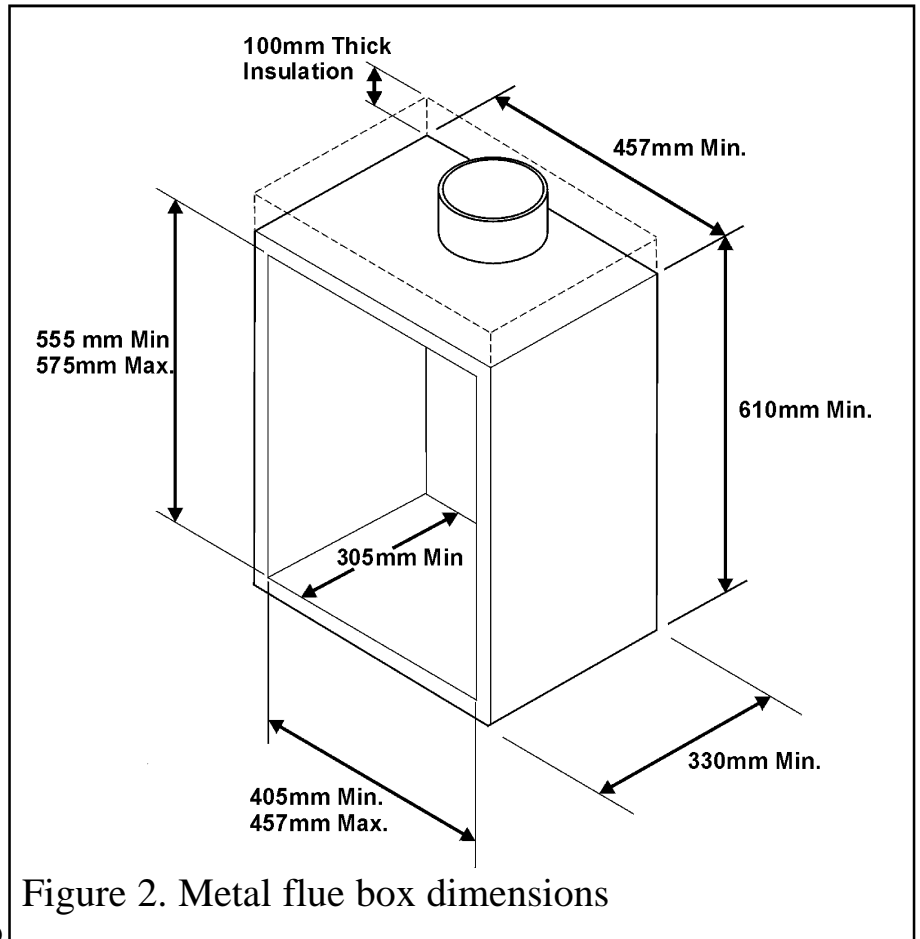

many bends, flue heights below three metres, restrictive terminations etc.

3.2.4 If the fireplace opening is greater than the acceptable dimensions given in this guide, do not use the back of a fire surround or marble to reduce the opening. This may cause cracking of the surround back or marble.

3.3 Suitable flues and minimum flue sizes are as follows: -

It should be noted that, as with many appliances, sharp bends or horizontal runs in metal flues at the top of the system can be a cause of problems in these types of installation.

- 225mm x 225mm conventional brick flue.
 - 175mm diameter lined brick or stone flue.
 - 200mm diameter factory made insulated flue manufactured to BS4543.
 - 175mm diameter flue pipe. See BS6461 Part 1 for suitable materials.
 - Single wall, twin wall or flexible flue liner with a minimum diameter of 125mm.
- The materials to be used are stainless steel or aluminium as specified in BS715. The liner must be sealed to the surrounding area above the fireplace opening and to the top of the chimney. An approved terminal must be fitted.
- A properly constructed precast concrete or clay flue system conforming to BS1289 or BS EN 1806. This system is only suitable if the conditions stated in section 3.2.3 are met.

INSTALLER GUIDE

3.4 The flue must conform to BS 5440: Part 1 in design and installation.

The flue, measured from the bottom of the fireplace opening to the bottom of the terminal, shall be not less than 3m in actual vertical height. When calculated in accordance with BS 5440: Part 1 Annex A, the minimum **equivalent** height of the flue shall be 2.0m of 125mm dia. flue pipe.

3.5 The flue must not be used for any other appliance or application.

3.6 Any chimney damper or restrictor should be removed. If removal is not possible, they must be secured in the open position.

3.7 If the appliance is intended to be installed to a chimney that was previously used for solid fuel, the flue must be swept clean prior to installation. All flues should be inspected for soundness and freedom from blockages.

3.8 If the fireplace opening is an underfloor draught type, it must be sealed to stop any draughts.

3.9 Note that soft wall coverings (e.g. embossed vinyl, etc.) are easily affected by heat. They may scorch or become discoloured when close to a heating appliance. Please bear this in mind when installing.

3.10 The front face of the fireplace should be reasonably flat over the area covered by the hotbox top and side flange seals to ensure good sealing. These faces should be made good if necessary. The fireplace floor should be reasonably flat to ensure that a good seal with the hotbox can be made.

3.11 The appliance must be mounted behind a non-combustible hearth (N.B. conglomerate marble hearths are considered as non-combustible). The appliance can be fitted to a purpose made proprietary class "O"-150°C surround. The hearth material

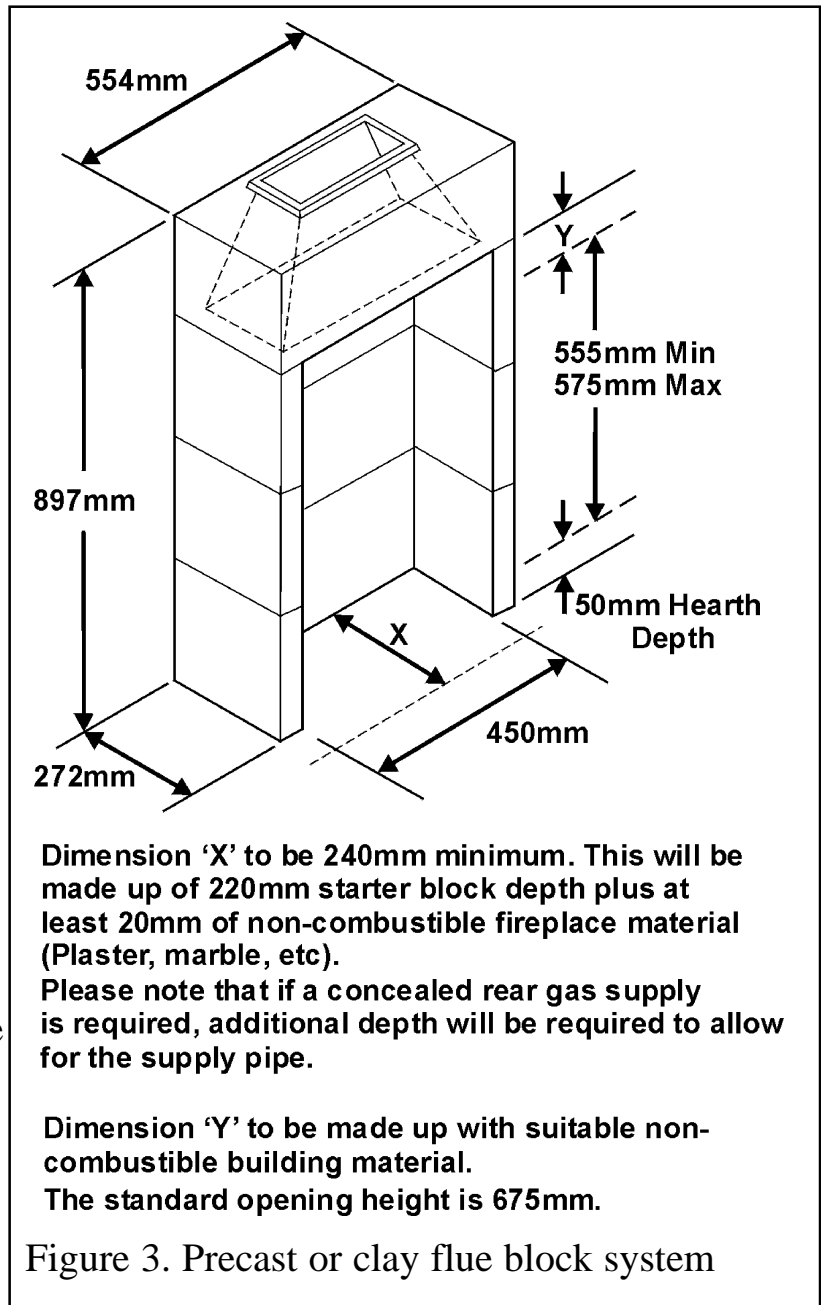

INSTALLER GUIDE

must be at least 12mm thick. The periphery of the hearth (or fender) should be at least 50mm above floor level to discourage the placing of carpets or rugs over it.

The surface of the hearth must be sufficiently flat to enable the bottom of the fascia and the bottom front cover to be aligned horizontally. Any excessive unevenness (uneven tiles, Cotswold stone, etc.) should be rectified.

The appliance must not stand on combustible materials or carpets.

3.12 This appliance must not be installed in any room that contains a bath or shower or where steam is regularly present.

3.13 An extractor fan may only be used in the same room as this appliance, or in any area from which ventilation for the appliance is taken, if it does not affect the safe performance of the appliance. Note the spillage test requirements detailed further on in this manual. If the fan is likely to affect the appliance, the appliance must not be installed unless the fan is permanently disconnected.

3.14 Normal adventitious ventilation is usually sufficient to satisfy the ventilation requirements of this appliance. In GB reference should be made to BS 5871 Part 2 and in IE reference should be made to the current edition of IS 813 “Domestic Gas Installations” which makes clear the conditions that must be met to demonstrate that sufficient ventilation is available.

3.15 The minimum height from the top surface of the hearth to the underside of any shelf made from wood or other combustible materials is detailed below.

- *For a shelf up to 150mm deep:* Minimum height = 760mm.
- *For a shelf deeper than 150mm:* 760mm + 12.5mm for every 25mm depth over 150mm. (See Graph 1).

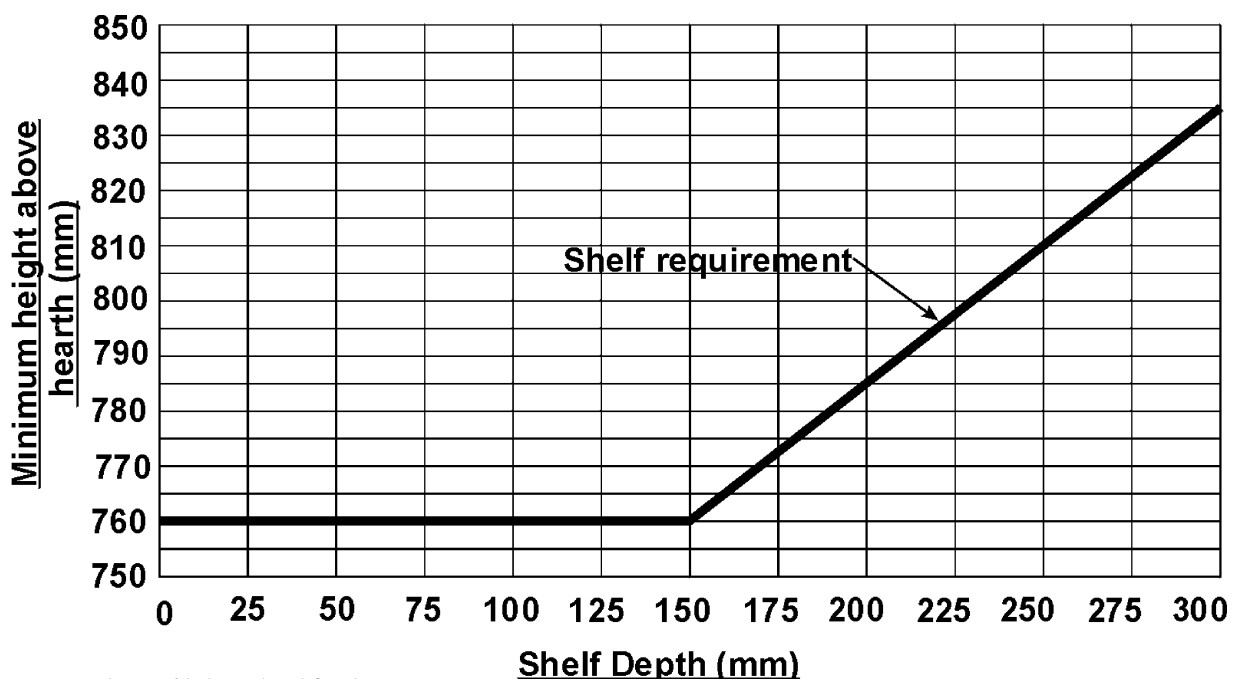

Graph 1. Combustible shelf clearances.

INSTALLER GUIDE

3.16 Propane gas appliances must not be installed in a room that is built entirely below ground level (See BS 5871 Part 2).

3.17 If the appliance is to be fitted against a wall with combustible cladding, the cladding must be removed from the area covered by the fascia. The cladding must also not touch the fascia (See figure 4). We suggest that the actual fascia is used as a template to mark the area for combustible cladding removal and that this area is increased by at least 2mm all round.

3.18 Proprietary terminals must comply with BS 715 or BS 1289. Any terminal or termination must be positioned in accordance with BS 5440 Part 1 to ensure that the products of combustion can be safely dispersed into the outside atmosphere. Where the appliance is connected to an unlined brick chimney it is generally unnecessary for the chimney pot to be replaced or for a terminal to be fitted unless the flue has a diameter smaller than 170mm.

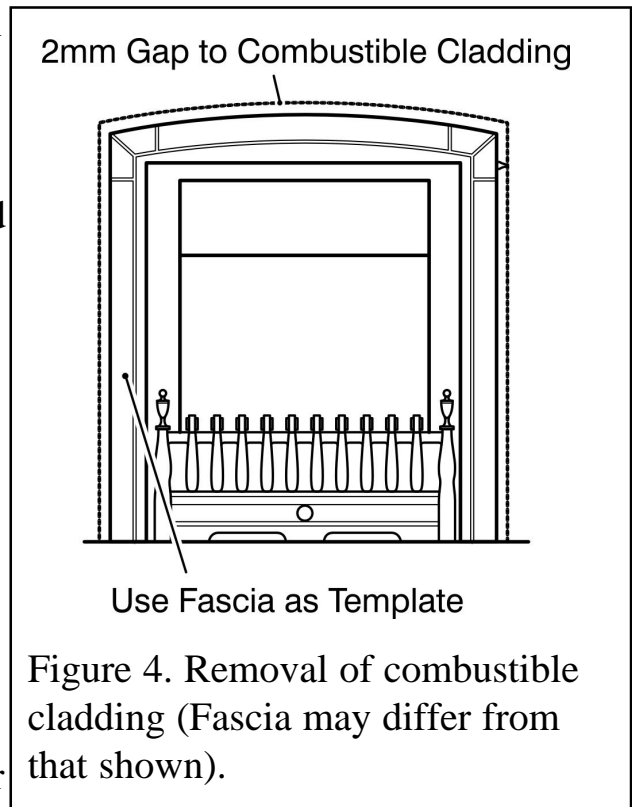

3.19 The minimum allowable distance from the outside of the appliance fascia to a corner wall having combustible material or any other combustible surface which projects beyond the front of the appliance is shown in figure 5. A 10mm access clearance from a non-combustible surface is necessary at the left side. (See figure 5).

3.20 The appliance is fitted with an A.S.D (Atmosphere sensing device). If the appliance closes down after a period of operation for no apparent reason, the consumer should be informed to stop using the appliance until the installation and appliance have been thoroughly checked. The A.S.D will shut the appliance down if an unacceptable amount of harmful products of combustion accumulate. Under no circumstances should the A.S.D be altered or bypassed in any way. Only a genuine manufacturers replacement part should be fitted. The individual A.S.D components are not replaceable.

3.21 A fireguard complying with BS 8423 should be fitted for the protection of young children, the elderly, or the infirm.

INSTALLER GUIDE

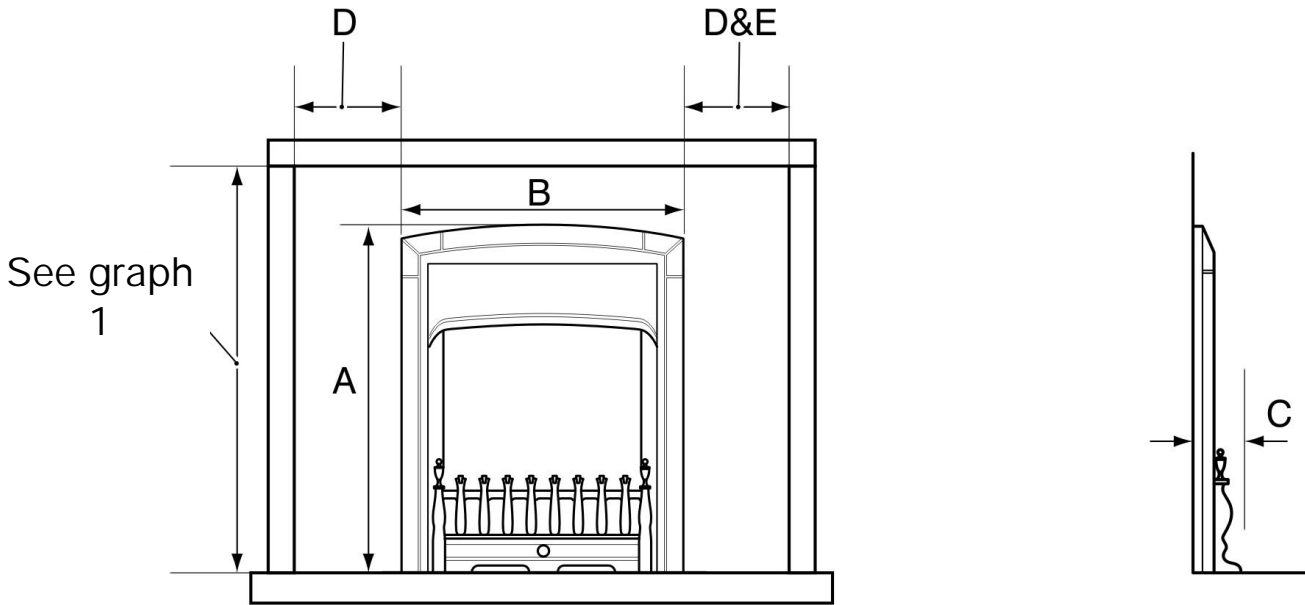

Key	Description	Dimension (mm)
A	Appliance height (mm)	606
B	Appliance width (mm)	518
C	Appliance depth into room (mm)	85
D	Minimum mandatory clearance to combustible surfaces projecting beyond the front of appliance (mm).	108
E	Recommended clearance to non-combustible surfaces for access purposes (mm).	108

Figure 5. Appliance dimensions and clearances (Fascia may differ from that shown)

INSTALLER GUIDE

4. PACK CONTENTS

The items required for this appliance are packed as below (See figure 6)

- 1 Burner and hotbox unit.
- 1 Nut and olive for 8mm inlet pipe.
- 1 Inlet 'T' connector and pressure test point.
- 1 Flue restrictor plate.
- 2 Screws (For flue restrictor).
- 2 Screws (For fireback spacing brackets).
- 2 Screws (For rear ceramic wall support bracket).
- 2 Washers (For fascia hanging).
- 2 Machine screws (For fascia hanging).
- 1 Ceramic back wall.
- 1 Pair of ceramic side walls.
- 1 Ceramic fuel effect pack (Not shown).
- 2 Small "U" seals for hotbox side flanges.
- 1 Strip of floor sealing tape.
- 6 Fibre plugs.
- 4 Woodscrews.
- 2 Fire retaining cables.
- 2 Cable clamps.
- 4 Eyebolts.
- 1 Rubber grommet.
- 1 PP3 Battery.
- 1 Knurled shouldered screw (For control linkage fixing).
- 1 Smoke match tube.
- 2 Fireback spacing brackets.
- 1 Rear ceramic wall support bracket.
- 1 Length of self adhesive foam seal.
- 1 Self adhesive control position label.
- 1 Literature pack.
- 1 Slider control unit .
- 2 Taptite or countersunk screws (For Slider control unit).
- 2 Fascia securing brackets.
- 1 Control position label.

Carefully remove all the contents. Take special care in handling the ceramic walls and the ceramic fuel effect. After fitting the slide control linkage, take care not to bend or distort the slide control linkage when handling the fascia.

Check that all the listed parts are present and in good condition.

INSTALLER GUIDE

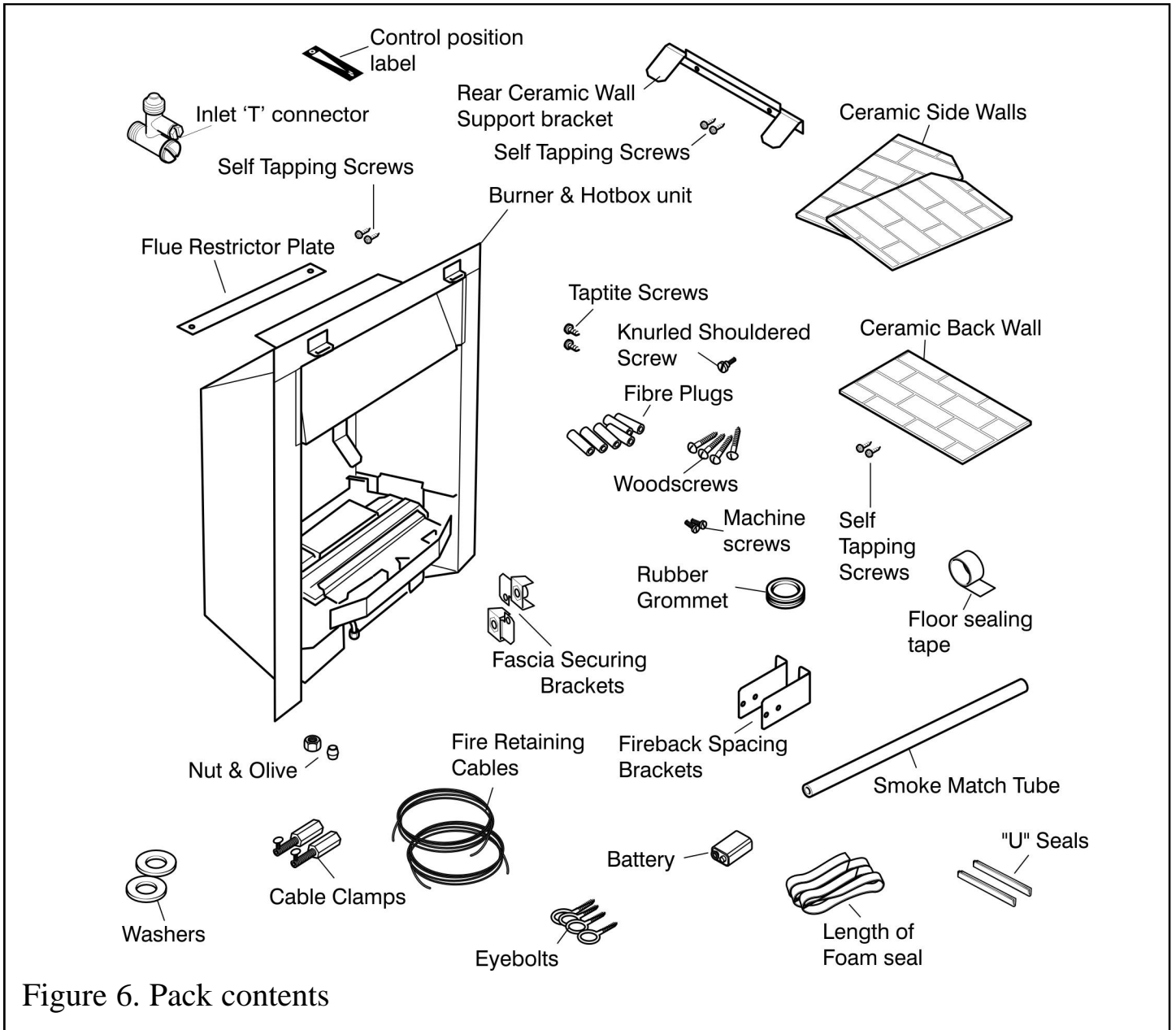

5. FIREPLACE CHECK

5.1 Fireplace check.

5.1.1 Fireplace size

The fireplace must comply with the requirements described in section 3.2. This will probably entail removing the fireback and infill material behind the fireback. On conventional fireplace openings the debris catchment area shown in figure 7 must be kept clear of obstructions.

5.1.2 Fireplace general condition

The fireplace floor should be reasonably flat to ensure that the hotbox can be installed without it rocking and so that a good seal can be made at the bottom front of the box. The front face of the fireplace should be reasonably flat over the area covered by the hotbox top and side flange seals to ensure good sealing. These faces should be made

INSTALLER GUIDE

good if necessary. If the appliance is to be fitted against a wall with combustible cladding, the cladding must be removed from the area covered by the fascia. The cladding must also not touch the fascia (See figure 4). We suggest that the actual fascia is used as a template to mark the area for combustible cladding removal and that this area is increased by at least 2mm all round.

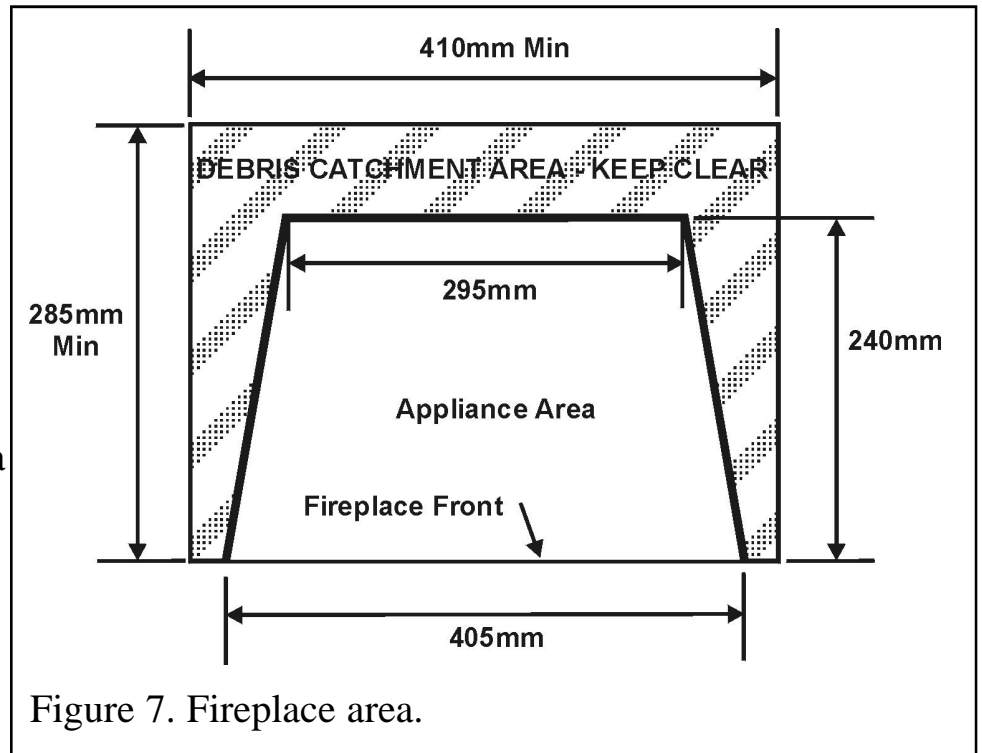

Figure 7. Fireplace area.

5.1.3 Soundness for appliance attachment

Two primary methods of retaining the appliance are provided: -

- 1) By fixing to the fireplace front surround.
- 2) Using concealed tension cables fixed to the rear of the fireplace opening together with secondary fixing to the fireplace floor.

The methods are detailed in section 9 of this manual. Before selecting the retention method, consult with the customer. Method 2 is provided for instances where drilling holes in the front surface of the fireplace surround is unacceptable to the customer or otherwise impractical. *N.B. It is unwise to attempt to drill into marble without the proper tools and equipment.*

If method 1 is chosen, make sure that the front surround area is sound enough to take the fibre plugs and woodscrews. If necessary, make sound with a suitable cement.

If method 2 is chosen, make sure that the areas at the back and towards the centre of the fireplace floor are sound enough to take the eyebolts and screws. If these areas have deteriorated due to prolonged use, they should be made sound with a suitable cement.

5.1.4 Installations using a metal flue box

The whole of the top surface of the metal flue box must be covered with a 100mm layer of mineral wool or equivalent insulation (See figure 2).

5.2 Fireplace flue pull.

Close all doors and windows in the room in which the appliance is to be installed. After confirming with a match that smoke is drawn into the flue, light a 13 gram smoke pellet and check that there is a definite flow through the flue. Verify outside that the smoke exits from one terminal only and that the termination is suitable. Observe, where possible, upstairs rooms and loft spaces for signs of escaping smoke indicating a

INSTALLER GUIDE

defective flue. If there is not a definite flow warm the flue for a few minutes and repeat the smoke pellet test. If there is still no definite flow the flue may need remedial work – **Do not fit the appliance until there is a definite flow through the flue.**

6. IGNITION CHECK

Before attempting to install, it is worth checking that the electronic ignition system performs satisfactorily.

Fit the battery to the ignition block located below the burner tray at the left side (See figure 8). The positive terminal (+) is to the bottom as you insert. Rotate the control pivot bracket clockwise as far as it will go and hold in this position (See figure 9). This should close the ignition circuit. Sparks should be seen tracking from the electrode pin to the pilot tip (See figure 9).

If there are no sparks make the following checks.

- Check condition of battery and that it is correctly fitted.
- If the above is satisfactory, check the ignition circuit and components - see the servicing section in this manual.

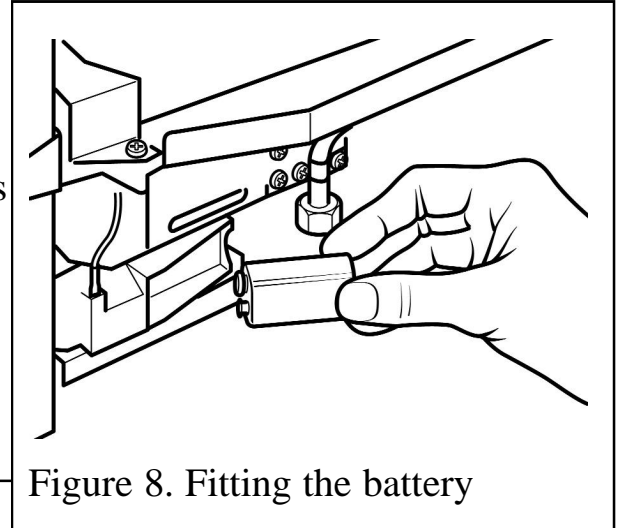

Figure 8. Fitting the battery

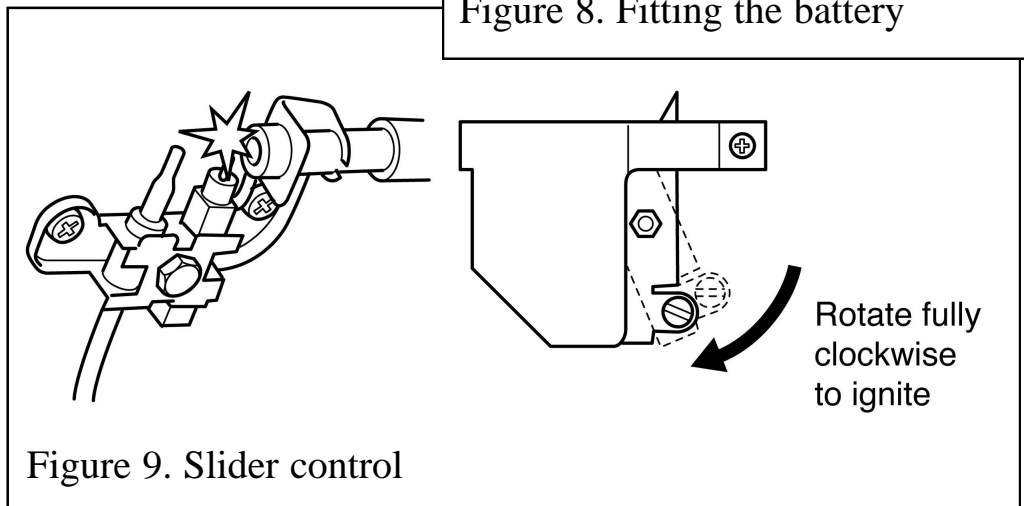

Figure 9. Slider control

7. GAS SUPPLY CONNECTION

A nut and olive are provided for an 8mm pipe inlet connection to the 'T' connector at the bottom front of the appliance. The 'T' connector can be rotated to allow a connection from any direction and includes a valve for isolating the gas supply and a pressure test point.

The supply pipe must be rigid material. Flexible pipe must not be used.

Concealed supply pipe connection.

If a concealed connection from inside the fireplace is required then, **before the appliance is fitted into the fireplace** it will be necessary to extend the supply line so that it will project through the hole in the back of the hotbox and run to the 'T' connector at the front. The pipe run from the supply line up to the rear opening in the

INSTALLER GUIDE

hotbox must be kept away from the area which will be taken by the hotbox when it is installed (See figure 7).

Note that the centre of the appliance inlet 'T' connector is 25mm above the fireplace floor. The inlet 'T' connector should be fitted to the supply pipe at this stage.

8. PREPARING APPLIANCE FOR INSTALLATION

IMPORTANT

Before continuing with the installation of this gas fire the aeration setting on the burner must be checked. The aeration is factory set, but will require adjustment (See section 16.1).

1. Detach the burner unit from the hotbox by removing two screws (See figure 10). Lift the burner unit clear.
2. Fit the two "U" section seals to the bottom edges of the hotbox side flanges (See figure 11).
3. **It is important that the grommet supplied in the loose parts pack is fitted to the hole in the rear of the hotbox.**

For concealed connection only:

4. Pierce the grommet to allow the pipe to pass through it. The grommet should envelop the pipe. If the hole is larger than the pipe, seal it with tape. **Do not pierce the grommet unless the supply pipe is to pass through it.**

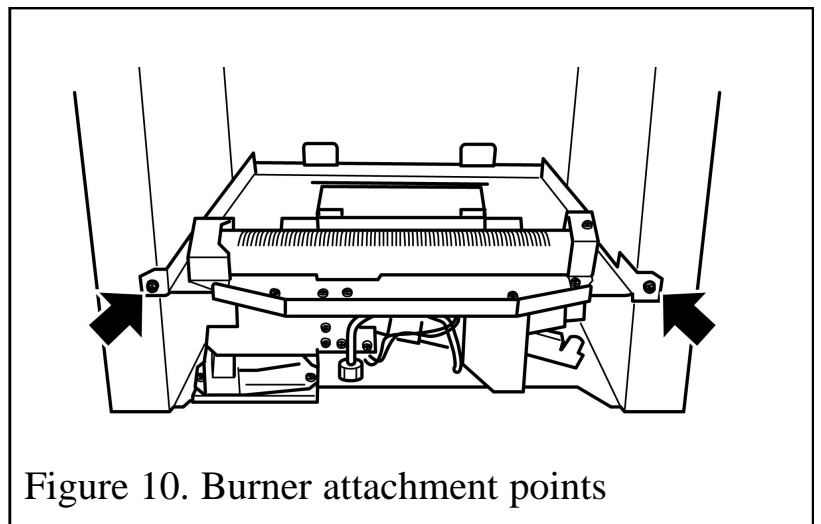

Figure 10. Burner attachment points

5. The appliance is supplied with two fireback spacers. **Do not fit the fireback spacers if the fire is to be installed into a precast or clay flue block system as in section 3.2.3.** These should extend backwards to ensure sufficient clearance from the back of the fireplace. Remove the label and retaining screws from the rear sides of the hotbox. Position the fireback spacer as shown in figure 12. Secure the fireback spacers using the screws removed previously and the two supplied with the fire.
6. This appliance is supplied with a flue restrictor for use where the flue draught is excessive. The restrictor must NOT be fitted where a precast flue or a flue liner is used. For all other installations the restrictor should be fitted.

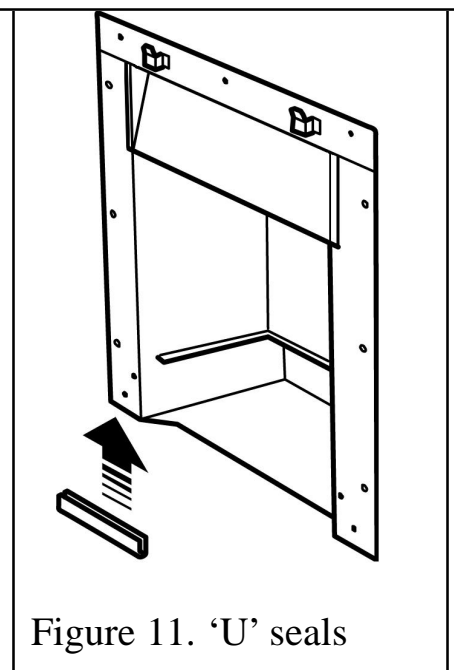

Figure 11. 'U' seals

INSTALLER GUIDE

There may however, be certain exceptional circumstances where fitting the restrictor causes the fire to fail the spillage test. In such cases the restrictor will have to be removed. After removal conduct the spillage check again. The restrictor is packed loose with the appliance and is fixed with two screws (See figure 13).

7. The upper corners of the hotbox flanges will have to be cut away. The area to be cut away is shown in figure 14.

8. There is a length of self adhesive foam seal supplied with the fire. This will need to be fitted to the outer rear edges of the side and top flanges of the hotbox. Be careful not to stretch the seal when measuring. Remove the protective backing from the foam seal and fit this to the flanges (See figure 15). Ensure that there is no gap between the foam seals where they meet at the top flange (See figure 15)

9. This appliance is supplied with a rear ceramic support bracket. Fit this using two screws supplied (See figure 16).

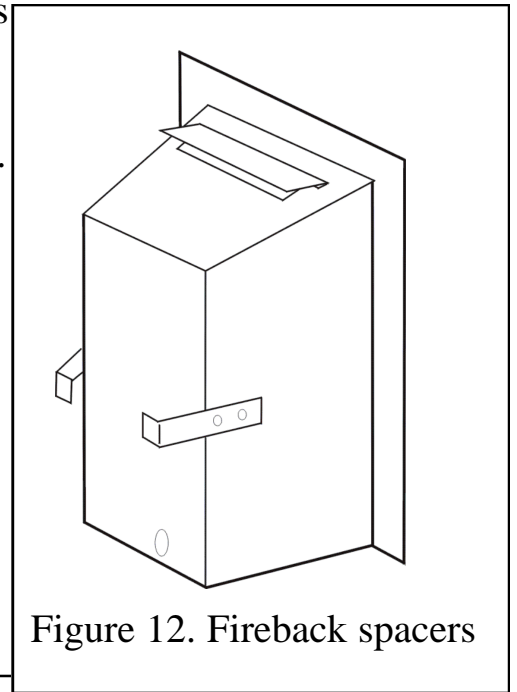

Figure 12. Fireback spacers

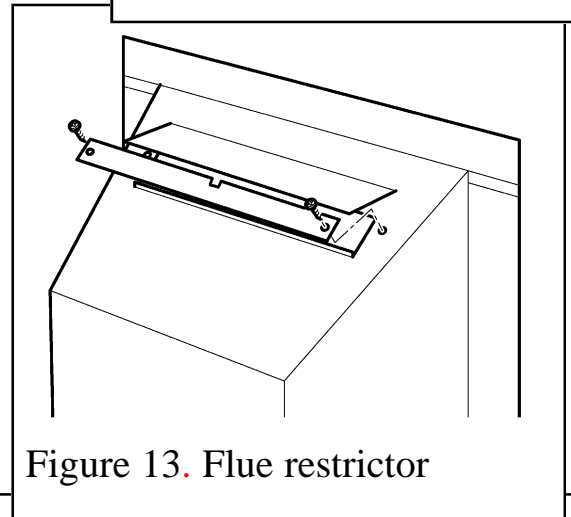

Figure 13. Flue restrictor

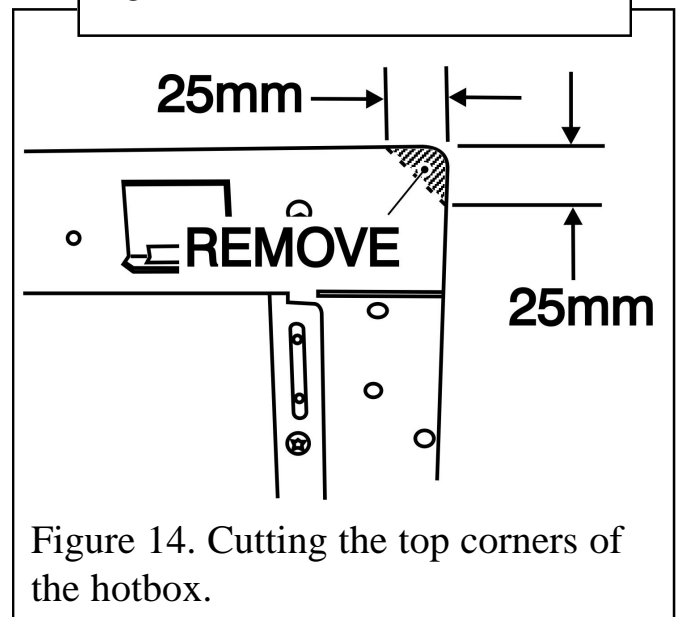

Figure 14. Cutting the top corners of the hotbox.

INSTALLER GUIDE

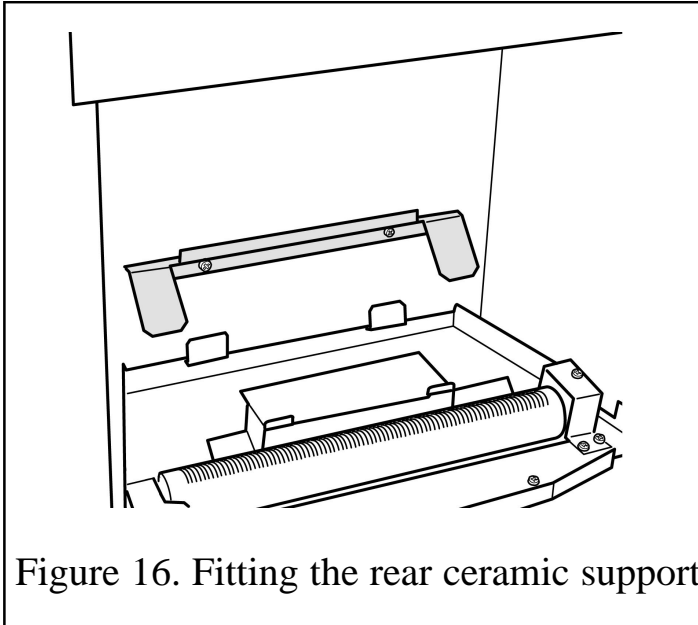

Figure 16. Fitting the rear ceramic support.

10. Fit the two surround securing brackets to the convection box side flanges with the screws supplied. Note the different orientation of the brackets at left and right sides (See figure 17)

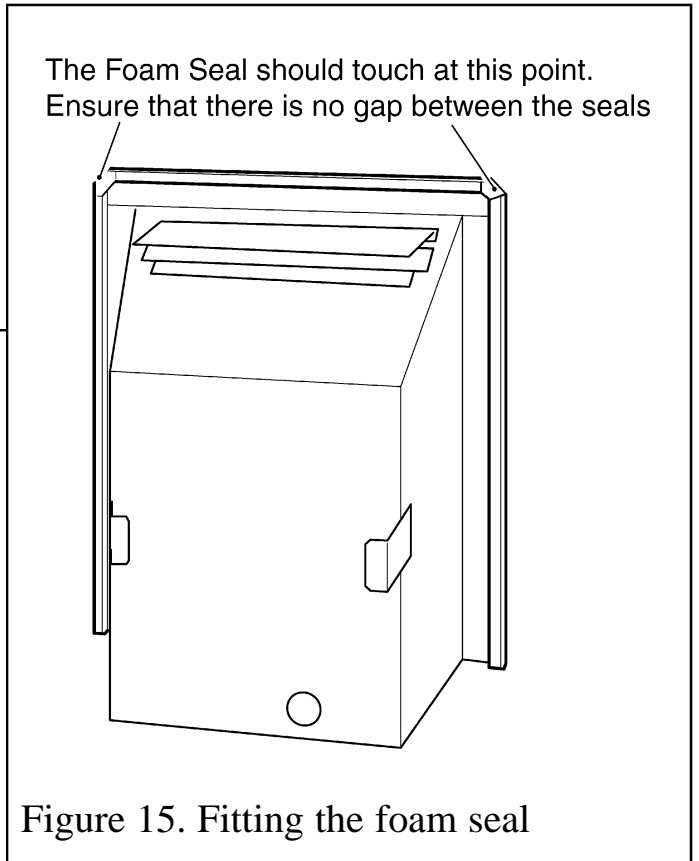

Figure 15. Fitting the foam seal

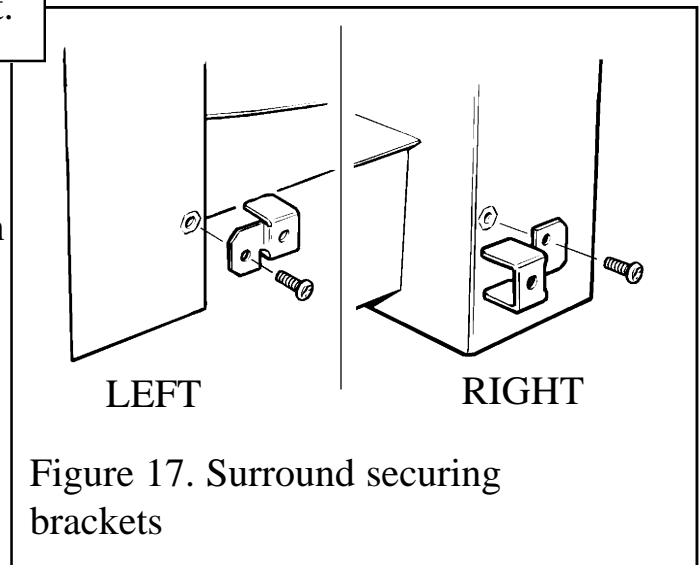

Figure 17. Surround securing brackets

9. HOTBOX INSTALLATION

9.1 Method 1 - Front fixing to fireplace surround.

1. Make sure that the fireplace front surround area is sound enough to take the fibre plugs and woodscrews. If necessary, make sound with a suitable cement.
2. Place the hotbox centrally in the fireplace in the position in which it is to be permanently installed. If a concealed connection is being used, insert the hotbox into the fireplace feeding the supply pipe through the pierced hole in the rear grommet.
3. Mark the fireplace front surround through the four fixing holes in the side flanges of the hotbox (See figure 18).

INSTALLER GUIDE

4. Remove the hotbox. Drill four holes in the fireplace front surround at the marked positions using a no.12 masonry drill.
5. Insert a fibre plug into each hole.
6. Place the hotbox back in position in the fireplace.
7. Fit a woodscrew through each hole in the hotbox flanges and tighten to seal the box to the fireplace surround.

9.2 Method 2 - Cable retention and floor fixing.

1. Make sure that the relevant areas at the fireplace back and floor are sound enough to take the eyebolts and screws. If these areas have deteriorated due to prolonged use they should be made sound with a suitable cement.

2. Drill four holes in the rear wall of the fireplace for the eyebolt plugs. The holes should be drilled within the range of positions shown in figure 19 using a no.12 masonry drill. The holes should be equidistant each side of the centre line of the fireplace to ensure that the appliance finishes centrally in the opening when tension is applied to the cables.

3. Insert a fibre plug into each hole. Use the fibre plugs supplied with this appliance - **Never use plastic plugs instead of the fibre plugs supplied.**

4. Place the hotbox unit close to the fireplace but allow sufficient access into the fireplace opening so that the cables can be threaded through the eyebolts and returned

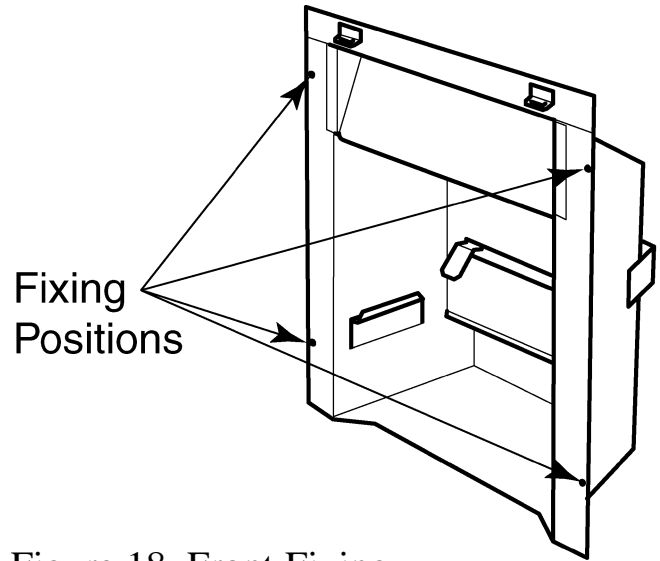
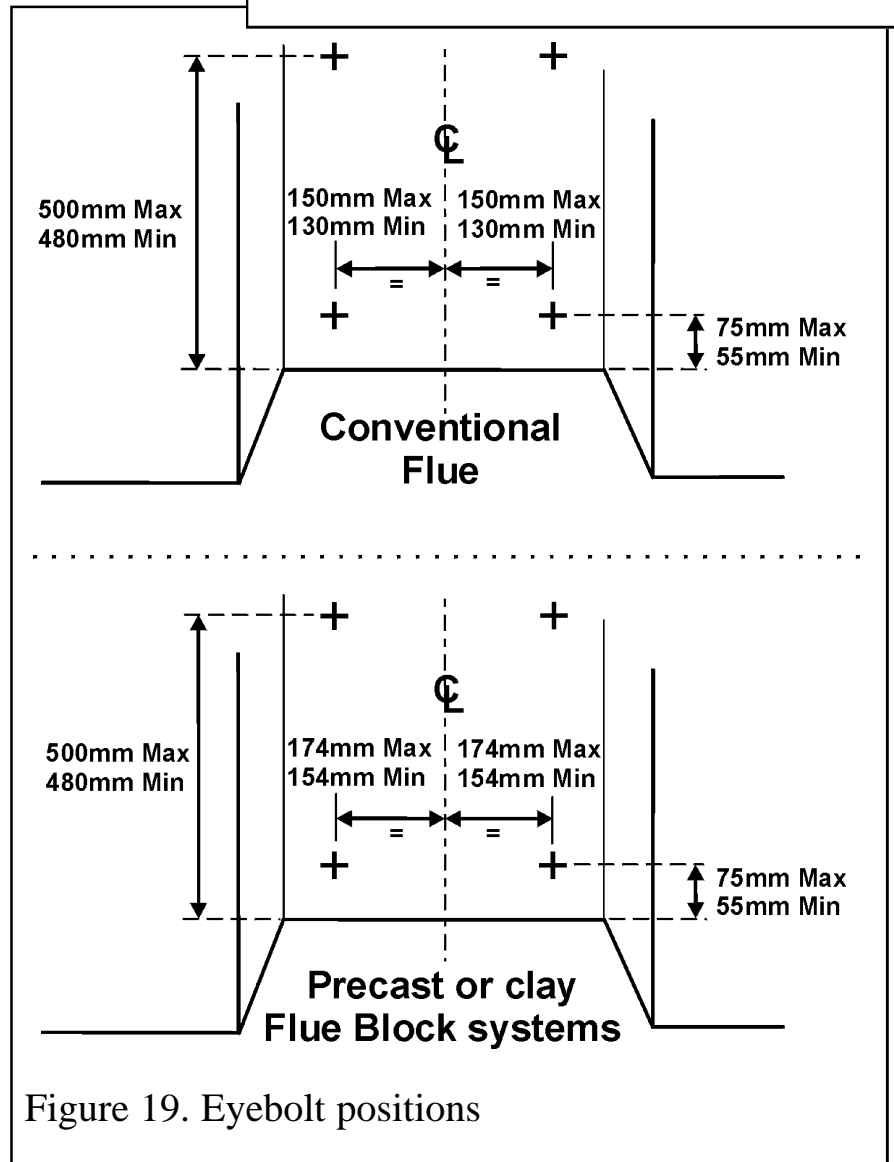

Figure 18. Front Fixing



INSTALLER GUIDE

through the back of the hotbox. If a concealed connection is being used, insert the hotbox into the fireplace feeding the supply pipe through the pierced hole in the rear grommet.

5. The hotbox has two holes at each side of the spillage plate. Insert one end of each cable (one cable each side) from the back through the lower of the two holes and return the end through the upper of the holes (See figure 20). Give the cables a pull so that they grip against the hotbox flanges.

6. Thread the cables through the eyebolts. Return the cables through the holes near the bottom of the hotbox back panel (See figure 21). **(For precast or clay block flue systems return the cables through the slotted holes in the side of the hotbox).**

7. Place the hotbox fully back into the fireplace opening so that it is sealed against the fireplace front surround.

8. Drill a hole into the fireplace floor through each of the two holes in the base of the hotbox using a no.12 masonry drill (See figure 22).

9. Insert a fibre plug into each hole. Use the fibre plugs supplied with this appliance - **Never use plastic plugs instead of the fibre plugs supplied.** Fit a woodscrew in each plug and tighten.

Always screw the base into position before applying tension to the cables. This will ensure a tight seal between the top of the hotbox and wall

10. Fit a cable retainer over the bottom end of each cable.

11. Pull each cable taut. Push the cable retainers hard up against the back panel. The end of the cable adjuster will pass into the hole. Tighten the screws in the retainers so that they clamp the cables in position. Apply tension to the cables by turning the hexagonal adjusters by hand (See figure 23).

12. Inspect the installation of the hotbox against the fireplace surround. If the hotbox is aligned squarely and the sealing is satisfactory, fully tighten the cable retainers.

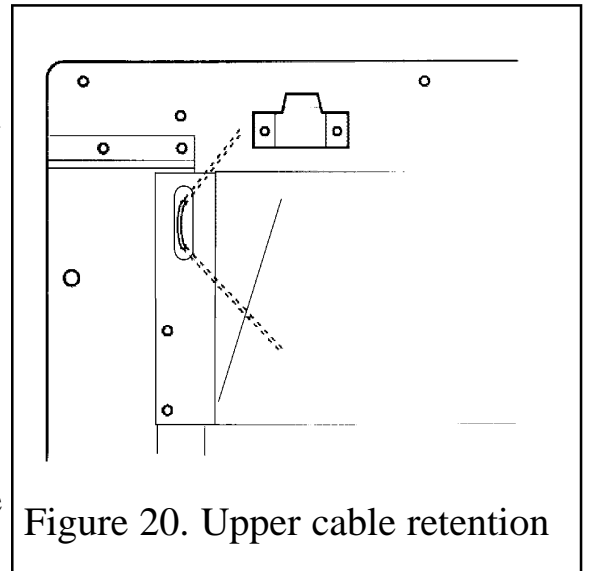

Figure 20. Upper cable retention

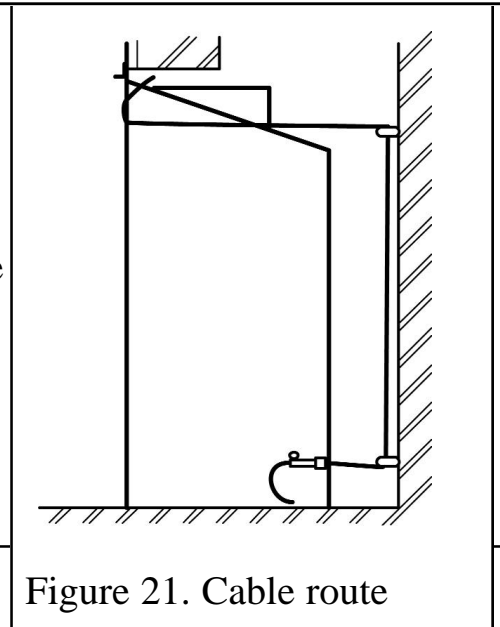

Figure 21. Cable route

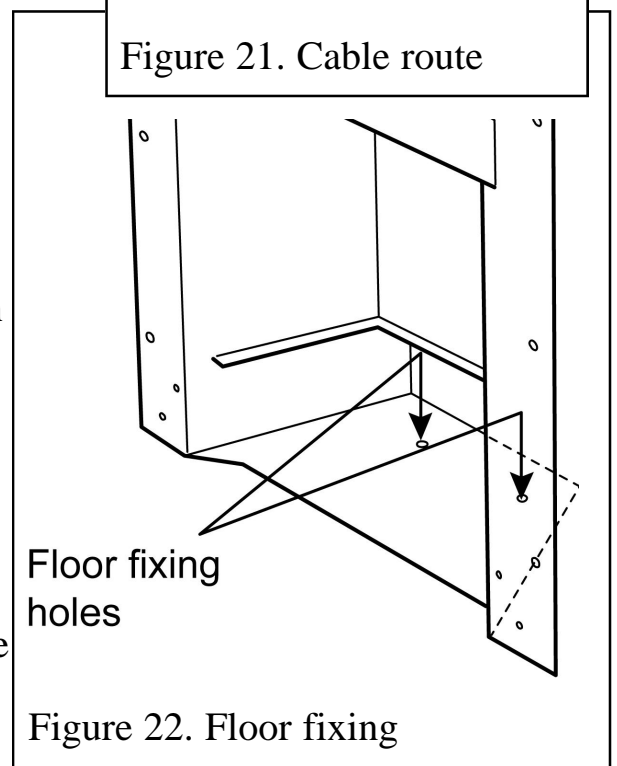

Figure 22. Floor fixing

INSTALLER GUIDE

13. If the hotbox is not correctly aligned, release the tension on the cables by slackening the screws and turning the hexagonal adjusters fully anticlockwise. The hotbox should then automatically realign itself. Pull each cable taut again and push the cable retainers back against the back panel / side panel. Again, tighten the screws in the retainers and apply tension to the cables by turning the hexagonal adjusters clockwise as far as possible.

14. Feed the free length of the cables into the gap between the inner and outer back panels so that they are available to allow easy removal and refitting of the appliance during subsequent service calls. **Do not cut off the free lengths of cable.** On precast flue installations feed the cables into the small holes at the base of the side panels (See figure 23).

9.3 Sealing floor front - All installations.

Using the floor sealing tape supplied, seal the bottom of the hotbox to the fireplace and hearth floor (See figure 24).

Make sure that the whole length of the front edge of the hotbox is fully sealed.

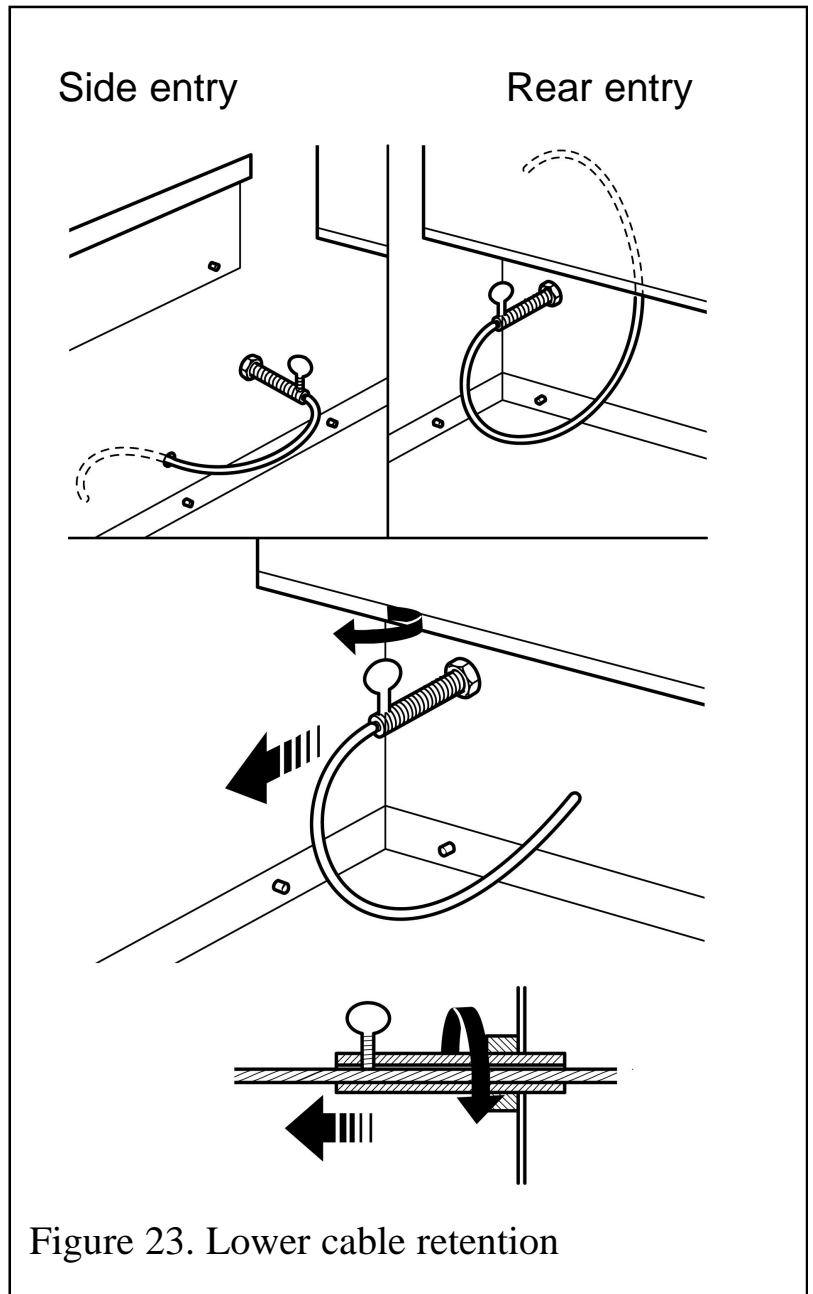

Figure 23. Lower cable retention

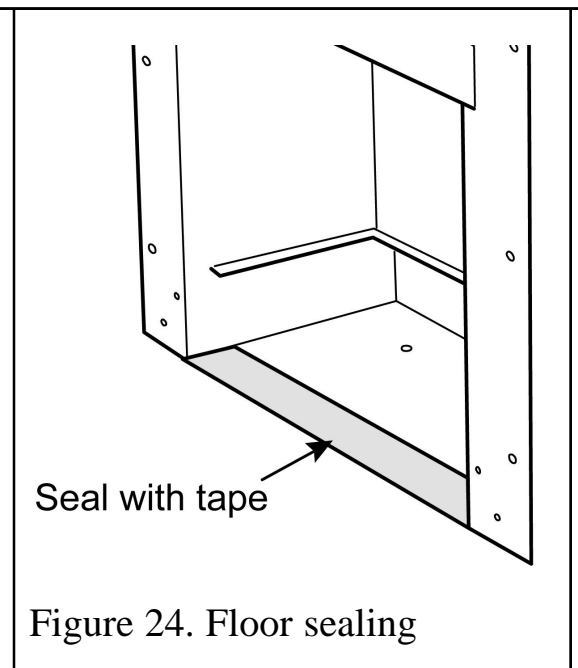

Figure 24. Floor sealing

INSTALLER GUIDE

10. BURNER & SUPPLY PIPE INSTALLATION

10.1 Burner and supply pipe installation.

1. Fit the burner unit to the hotbox with two screws previously removed.
2. Connect the supply line to the appliance.
3. Turn on the gas supply and pressure check the installation pipework for gas soundness. In the United Kingdom (GB) check in accordance with the current edition of BS 6891. In the Republic of Ireland (IE) check in accordance with the current edition of IS 813 “Domestic Gas Installations”.

10.2 Preliminary burner checks.

Some burner operations can be checked at this stage. Checking now will mean that less disassembly will be required if any problems are found. ***A full check should still be made, however, after final installation.***

1. If closed, open the isolating valve at the inlet ‘T’ connector.
2. Rotate the control pivot bracket clockwise as far as it will go and hold in this position (See figure 25). This should close the ignition circuit and simultaneously open the gas tap allowing the gas to flow to the pilot. Wait a few seconds while the air is purged. The electronically generated sparks should light the pilot. The pilot should then light the main burner at its low setting. There may be a delay of up to four seconds between the pilot lighting and ignition of the gas at the main burner. This is normal and is due to the time required to fill the main burner compartment with sufficient gas for ignition.
3. When the burner is operating properly, gradually turn the control pivot bracket anti-clockwise. The burner flames should gradually increase until the pivot bracket is nearly at its furthest anti-clockwise rotation. Rotating further until the pivot bracket comes to a stop should then turn the burner and pilot off.
4. If the above checks are satisfactory, continue with the installation. If not, check the control and ignition circuitry and components as described in the servicing section of this guide.

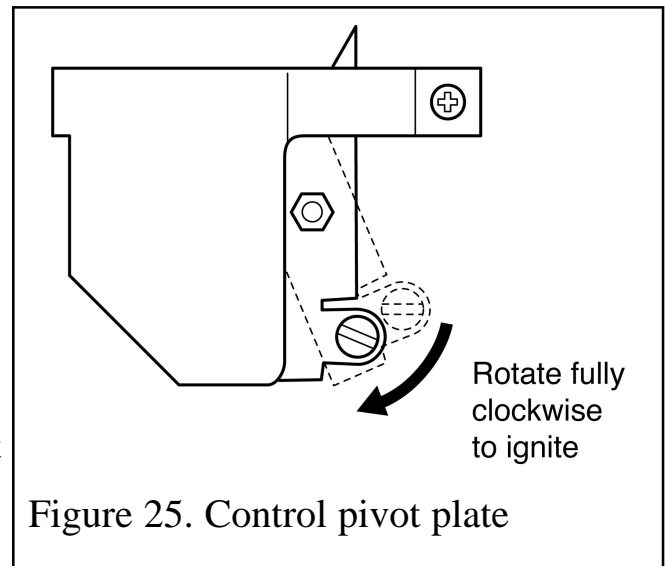

Figure 25. Control pivot plate

10.3 Inlet pressure check.

The appliance is pre-set to give the correct heat input at the inlet pressure shown in section 2 of this manual. No adjustment is necessary.

1. Check the inlet pressure by fitting a pressure gauge at the test point. The test point is on the inlet ‘T’ connector (See figure 26). Check the pressure with the appliance alight

INSTALLER GUIDE

and set at maximum output.

2. After checking, turn off the appliance. Remove the pressure gauge and replace the test point sealing screw.

3. Light the appliance. Turn to the maximum output position and test around the sealing screw for gas soundness with a suitable leak detection fluid.

When the above checks from section 10.2 and 10.3 have been completed close the isolating valve on the inlet 'T' connector.

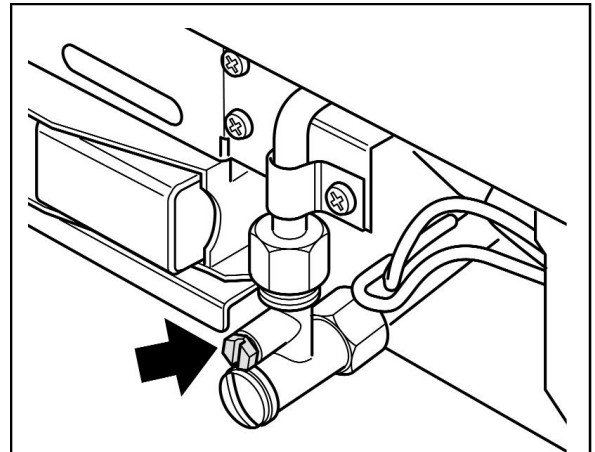

Figure 26. Pressure test point

11. CERAMIC WALLS INSTALLATION

1. Fit the ceramic rear wall inside the "L" bracket on the back face of the burner compartment. Push the ceramic wall flat against the back face of the burner compartment (See figure 27).

2. Fit the ceramic side walls against the side faces of the burner compartment. The bottom edges of the walls should rest in the ledges at the sides of the firebox. Slide them in from the front and ensure that they touch the rear wall. Be careful not to damage the edges of the side walls (See figure 28).

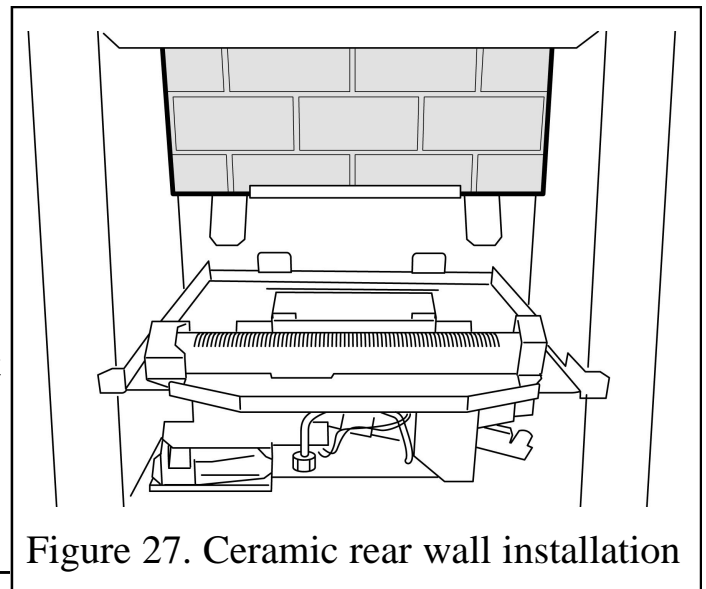

Figure 27. Ceramic rear wall installation

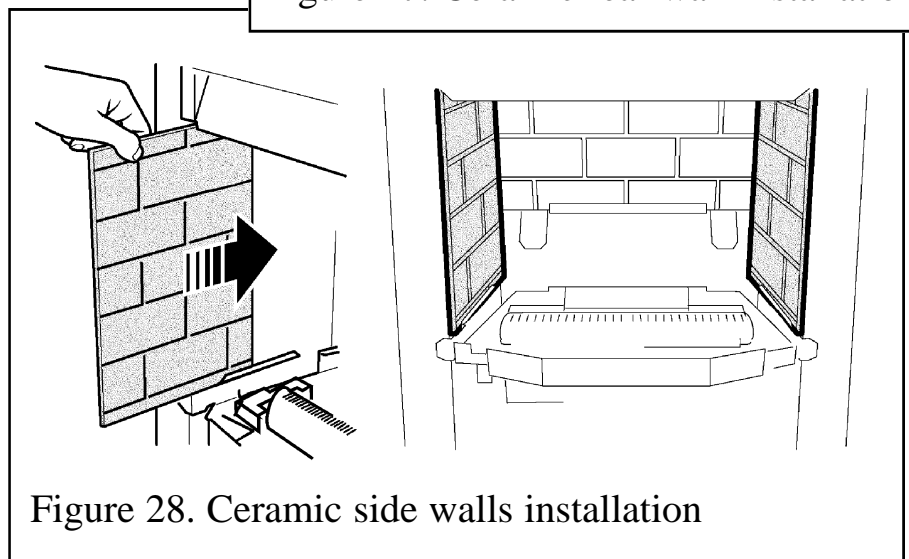
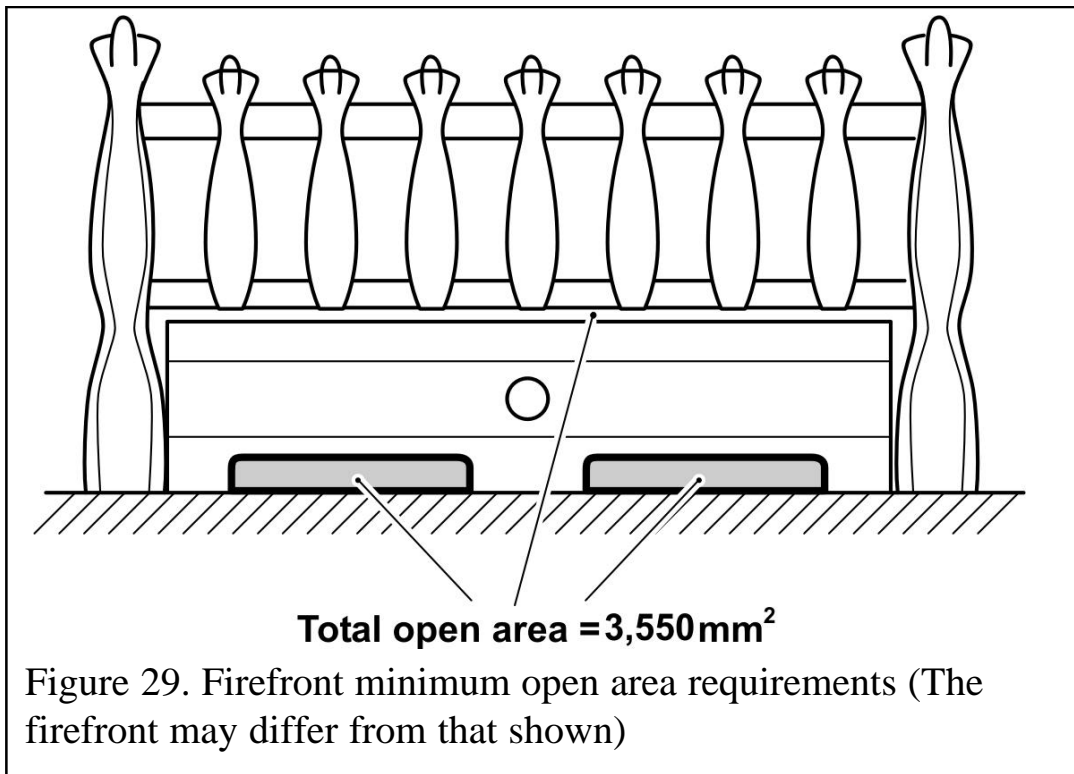

Figure 28. Ceramic side walls installation

INSTALLER GUIDE

12. FITTING THE FASCIA

- There is a self adhesive control position label and control slider assembly supplied with this fire. These should be fitted to the fascia as shown in the fascia fitting guide. The fitting guide for the fascia is supplied with the fascia and the fascia should be fitted in accordance with it. The control position label should be located close to the control knob.
- A slotted firefront with a **minimum** free area as shown in figure 29 must always be used.



13. FITTING THE CERAMIC FUEL EFFECT

The fitting guide for the ceramic fuel effect is supplied with the ceramic fuel effect. It is important that the fitting guide for the ceramic fuel effect be placed inside or attached to this guide and handed to the customer following completion of the ‘final review’ section.

14. FULL OPERATING CHECKS

14.1 Check the control settings.

The control position markings on the fascia are shown in figure 30.

Please note:

- *When first turned on from cold, the flames will appear predominantly blue.*

INSTALLER GUIDE

- When operating the fire for the first time, some vapours may be given off which could set off smoke alarms in the vicinity. These vapours are quite normal with new appliances. They are totally harmless and will disappear after a few hours use.

1. Make sure the slider button is at the off position (At topmost position marked “O” on the fascia).
2. Open the isolating valve on the inlet ‘T’ connector. Replace the sealing screw and test around the sealing screw for gas soundness with a suitable leak detection fluid.
3. Slide the button to the bottom (ignition) position

marked . Retain in this position to ignite the pilot. The

burner should ignite at its lowest setting within 4 seconds of the pilot igniting. Keep at this position for a further 10 seconds to allow the pilot flame to stabilise.

4. Release the button. The button should automatically spring up to the low heat position. If the flames go out at this stage or when checking the rest of the setting positions, try the full lighting sequence again. If the flames fail after two attempts, investigate the pilot unit.
5. Gradually slide the button up to increase the burner setting. The burner should be at its maximum setting at the high heat position shown in figure 30. You should feel a check to the button movement at this position.
6. Slide the control button up past the high heat position to the off (“O”) position at the top of the slide slot. Both pilot and main burner should go out. While cooling the ceramic fuel effect may make some crackling noises. This is quite normal.

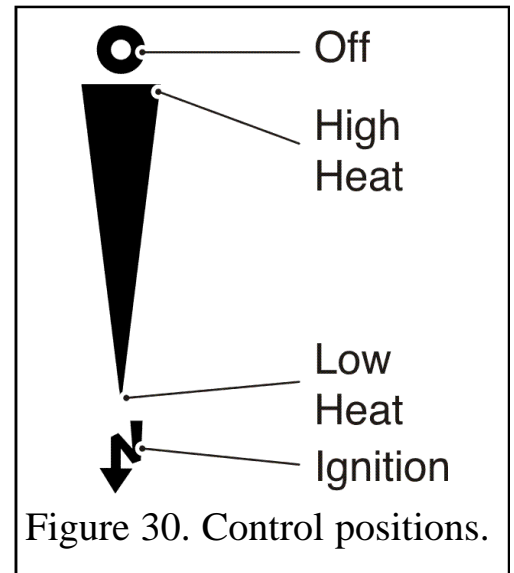

Figure 30. Control positions.

14.2 Check for spillage.

A spillage check must be made before leaving the installed appliance with the customer. Make this with all the ceramic fuel effect pieces in position.

1. Close all doors and windows in the room containing the appliance.
2. Light the appliance and set the slide control to the maximum burning position.
3. Leave the appliance on for five minutes.
4. The smoke match should be placed horizontally into the hotbox at the right hand side (See figure 31). The installation is satisfactory if the smoke is drawn into the appliance. If the smoke is not drawn into the appliance leave the appliance alight at the maximum setting for a further ten minutes and then repeat the test. If the smoke is still not drawn into the appliance inspect the sealing to the fireplace surround. If the sealing is satisfactory but the appliance is installed with the flue restrictor (See section 8 point 6)

INSTALLER GUIDE

remove the restrictor, reseal the appliance and retest. If smoke is still not drawn into the appliance **disconnect the appliance and seek expert advice.**

5. If the above test is satisfactory open all internal connecting doors, hatches, etc. in the room. Keep all doors and windows that open to the outside of the building closed. Check for spillage as above. If an extractor fan is installed in the same room as the appliance or a connecting room, check that spillage does not occur with the fan operating and all doors and other openings between the fan and the appliance open.

If the smoke is drawn into the appliance, continue with the installation. If the test is not satisfactory **disconnect the appliance and advise the customer of the cause of failure.**

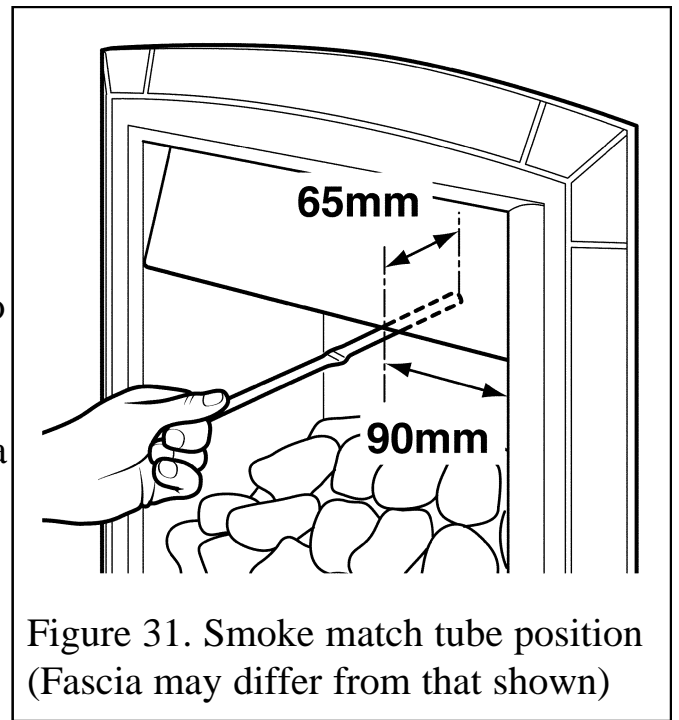

Figure 31. Smoke match tube position (Fascia may differ from that shown)

15.3 Flame supervision and spillage monitoring system.

This pilot unit includes a system that will automatically shut off the gas supply if the pilot flame goes out or if there is insufficient oxygen due to spillage or poor ventilation. Check that the system operates properly as follows;

1. Light the appliance. Set the slide control to the maximum burning position and leave for one minute.
2. Set the control to the low burning position. Isolate the gas supply at the inlet 'T' connector. The pilot and main burner will go out. **Note the time when the pilot goes out.** Listen for a snap sound at the gas tap. **Note the time when the sound is heard.** This sound is caused by an electromagnetic valve shutting off the gas supply through the tap. The valve is located in the body of the tap. The valve should operate **within 60 seconds of the pilot going out.** If the valve does not operate within this time limit do not allow the appliance to be used until the fault has been corrected.
This monitoring system must not be adjusted, bypassed or put out of operation. This monitoring system, or any of its parts, must only be exchanged using authorised parts.
3. Open the isolating valve on the inlet 'T' connector. Screw on the end cap and test for leaks.
4. Set the slider to the "Off" ("O") position.

INSTALLER GUIDE

15. FINAL REVIEW

1. If a gap is visible between the inner sides of the fascia and the ceramic side walls, gently slide the walls forward.
2. Visually inspect the appliance. Clean off any marks incurred during installation.
3. Advise the customer how to operate the appliance. Point out that lighting instruction details are on the metal plate attached at the bottom of the appliance. Explain to the customer that the appliance has a flame failure & spillage monitoring system. Point out the explanation of this system shown in the owner guide under “Operating the fire”. Advise that if the fire goes out for any reason, wait at least three minutes before relighting. Stress that if the monitoring system repeatedly shuts off the fire, the appliance should be switched off and a specialist should be consulted.
4. Advise the customer that they should read their owner guide before operating the fire and always follow the advice in the section headed “Cleaning your fire”.
Stress that no extra ceramic fuel effect pieces must be added over and above those supplied with the appliance and that any replacements must only be the authorised spares. Warn that ignoring this advice could cause incomplete clearance of the products of combustion with consequent health hazards.
6. Advise the customer that the appliance will operate to its maximum potential if the flue is primed during the first 20 – 30 minutes of use. To do this, simply slide the control to its highest setting. This will also burn off any carbon deposits that may have formed during previous use.
If using the appliance for long periods it is beneficial to change between settings. This will also help to remove any carbon deposits that may form during use.
7. Recommend that the appliance should be serviced by a competent person at least annually.
8. If the appliance is in premises in the United Kingdom occupied by a tenant, point out that by law a landlord must have any gas appliance, flue and pipework which is situated in a tenant’s premises checked for safety at least every 12 months.
9. Advise that the fire may give off a slight odour while new. This is quite normal and it will disappear after a short period of use.
10. **Inform the customer that the Serial number for the appliance is located on the data label / swing plate, located behind the lower front casting and underneath the burner module.**
11. Hand the literature pack with this guide to the customer.

INSTALLER GUIDE

16. SERVICING & PARTS REPLACEMENT

Always turn off the gas supply and allow the appliance to cool completely before commencing any servicing (The appliance inlet 'T' connector incorporates an isolating valve).

It is recommended that, at least once a year, the appliance is disconnected and the fireplace opening checked and cleared of any debris.

This product uses fuel effect pieces and burner compartment walls containing Refractory Ceramic Fibres (RCF), which are man-made vitreous silicate fibres. Excessive exposure to these materials may cause irritation to eyes, skin and respiratory tract. Consequently, it is important to take care when handling these articles to ensure that the release of dust is kept to a minimum. To ensure that the release of fibres from these RCF articles is kept to a minimum, during installation and servicing we recommend that you use a HEPA filtered vacuum to remove any dust and soot accumulated in and around the fire before and after working on the fire. When replacing these articles we recommend that the replaced items are not broken up, but are sealed within a heavy duty polythene bag, clearly labelled as RCF waste. This is not classified as "hazardous waste" and may be disposed of at a tipping site licensed for the disposal of industrial waste. Protective clothing is not required when handling these articles, but we recommend you follow the normal hygiene rules of not smoking, eating or drinking in the work area and always wash your hands before eating or drinking.

- Check that the appliance is clean and that soot or debris is not blocking the gaps between the ceramic fuel effect pieces causing an imperfect flame.
- Check that soot or debris is not impairing the electrode spark or pilot burner.
- Check that soot or debris is not blocking any of the slots in the main burner.
- After servicing, make sure that the ceramic walls are replaced correctly as described in this guide and the ceramic fuel effect pieces are replaced correctly as described in the installer and owner guide supplied with the ceramic fuel effect. The ceramic fuel effect guide may have been placed inside or attached to this guide.
- **Always test for gas soundness and spillage after servicing the appliance.**

INSTALLER GUIDE

16.1 Checking the aeration setting of the burner.

1. The aeration shutter is factory set and **will** require adjustment. **It is important to ensure that the aeration setting is correct (See figure 32).**
2. To adjust the aeration setting, loosen the two aeration shutter screws, slide the aeration shutter to the position shown in figure 32 and tighten the fixing screws.

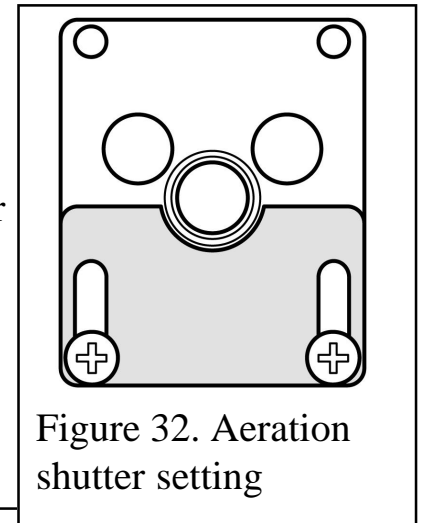

Figure 32. Aeration shutter setting

16.2 To remove the ignition microswitch.

(See figures 33 & 34).

The ignition microswitch is stamped V4NT9C4YC

1. Remove the fascia.
2. Detach the microswitch cover by removing one screw and pulling clear of the location lug (See figure 33).
3. Disconnect the leads from the ignition microswitch (The lower of the two microswitches (See figure 34).
4. Detach the microswitch and insulation pad by removing two screws.
5. Replace in the reverse order. Check that the microswitch operates correctly by fully closing it and observing that there are sparks at the pilot electrode.

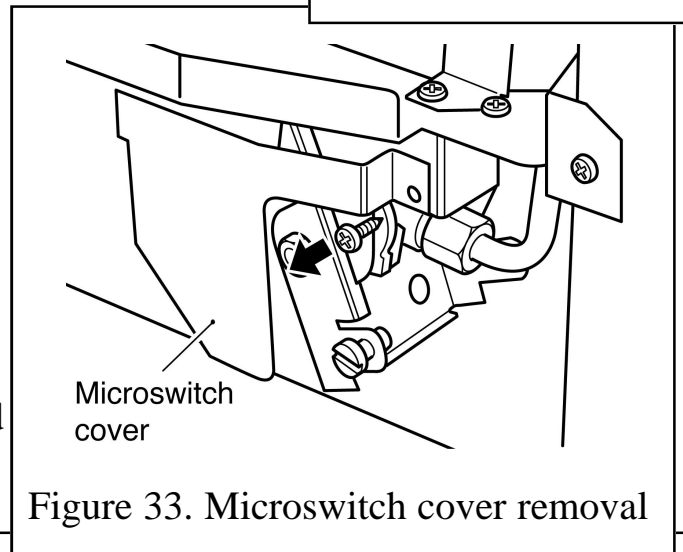

Figure 33. Microswitch cover removal

16.3 To remove the gas shut-off microswitch.

(See figures 33, 34 & 35).

The gas shut-off microswitch is stamped V4NT9C2YCGPX or V4NT9C2YCAUX.

1. Remove the fascia. as in section 16.4
2. Detach the microswitch cover by removing one screw and pulling clear of the location lug (See figure 33).
3. Loosen the thermocouple nut to free the microswitch leads and pull the leads clear of the thermocouple interrupter block (See figure 35).
4. Detach the bridging bracket, microswitch assembly by removing two screws (See figure 34).
5. Replace in the reverse order. When refitting the leads to the interrupter block, make sure that they are secured firmly to give a good electrical contact.

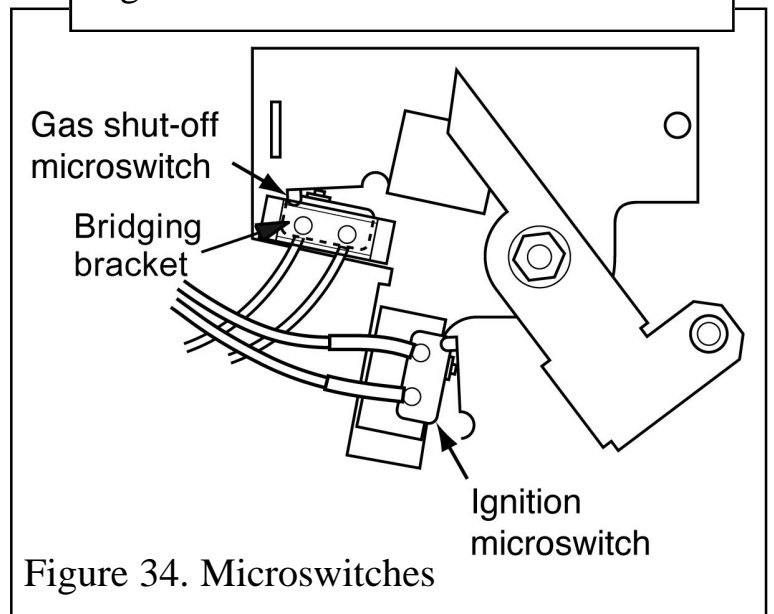

Figure 34. Microswitches

INSTALLER GUIDE

16.4 To remove the fascia.

1. Remove the bottom front cover.
2. Detach the control-linking bar from the control pivot bracket by removing the knurled screw, which joins the control linking bar to the control pivot unit (See figure 36).
3. Remove the two screws and washers securing the bottom of the fascia to the sides of the hotbox (See figure 37).
4. **Make sure that the control linking bar has been detached (See 2 above).** Carefully lift the fascia unit upward to clear the upper retaining brackets on the hotbox (See figure 38). Pull the fascia clear and place carefully aside.
5. Refit in the reverse order. Make sure that the fascia is properly located over the upper retaining brackets.

16.5 To replace the control slide unit.

1. Remove the fascia (See section 16.4).
2. Detach the slide unit by removing two screws securing the plastic slide mechanism to the rear of the fascia (See figure 39).
3. Replace in the reverse order.

16.6 To replace the control slide button.

1. Remove the fascia (See section 16.4).
2. Remove the control slide unit as in section 16.5
3. Detach the slide button by removing two screws
4. Replace in the reverse order.

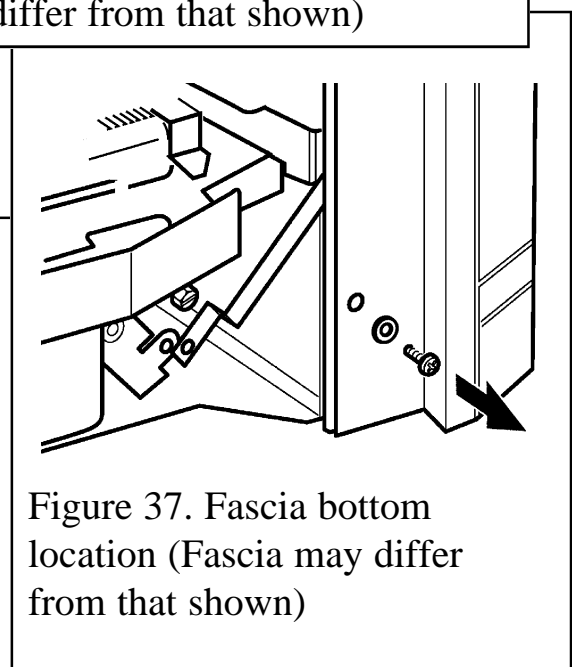
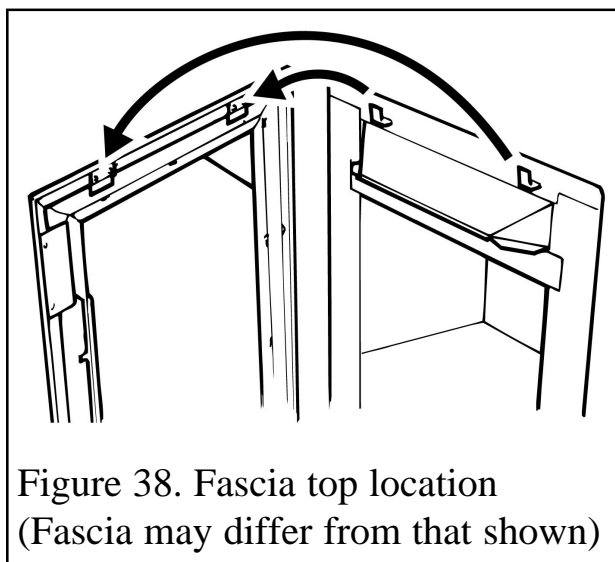
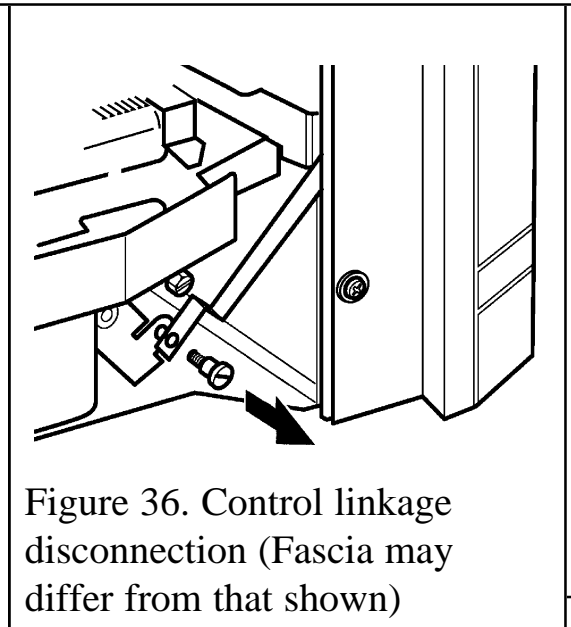
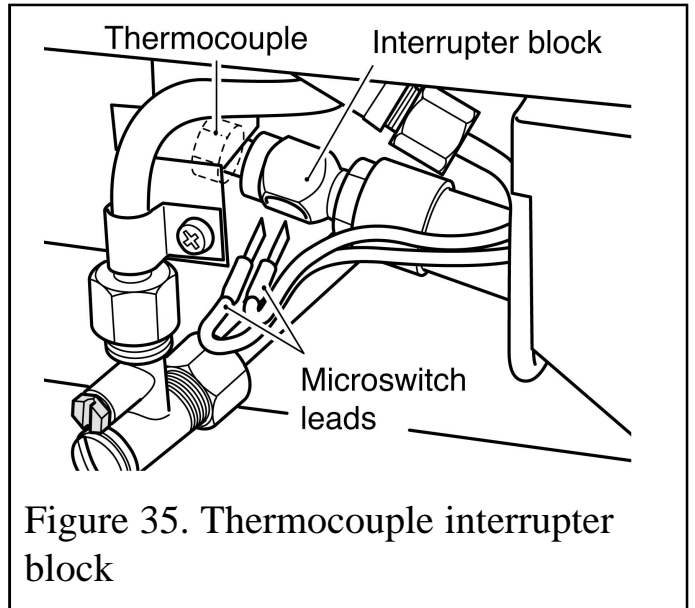

INSTALLER GUIDE

16.7 To remove the burner unit.

1. Remove the fascia (See section 16.4).
2. Remove the ceramic fuel effect
3. Support the inlet 'T' connector to avoid straining the pipework and disconnect the appliance from the inlet 'T' connector.
4. Detach the burner unit from the hotbox by removing two screws (See figure 40).
5. Replace in the reverse order.

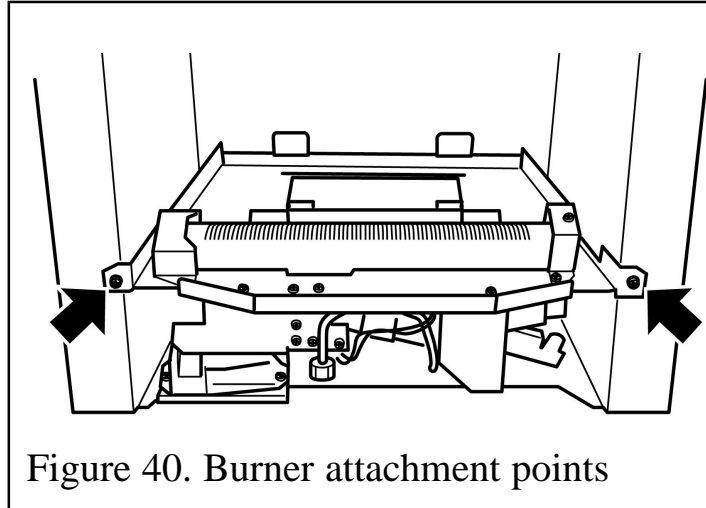

Figure 40. Burner attachment points

16.8 To remove the electronic ignition generator.

1. Remove the bottom front and fire front castings (See section 16.4).
2. Remove the ceramic fuel effect.
3. Remove the battery.
4. Remove the spark lead.
5. Unscrew the four support bracket screws (See figure 41). The generator and its support bracket can now be moved forward. Be careful not to apply tension to the microswitch leads.
6. Remove the two fixing screws that attach the generator unit to the support bracket. The igniter generator can now be removed (See figure 41).
7. Remove the two leads to the switch and remove the spark lead. If necessary, mark them to ensure that they are replaced on to the correct terminals.
8. Replace the generator
9. Refit in the reverse order.

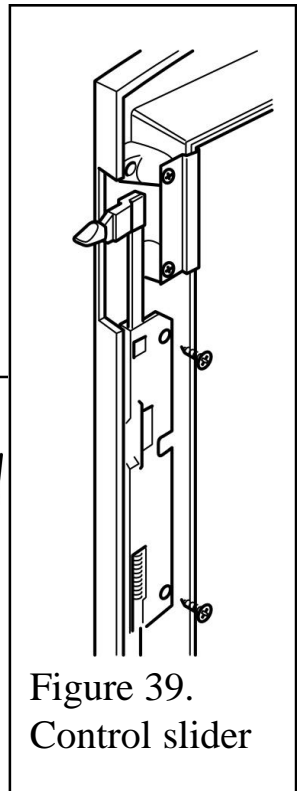

Figure 39.
Control slider

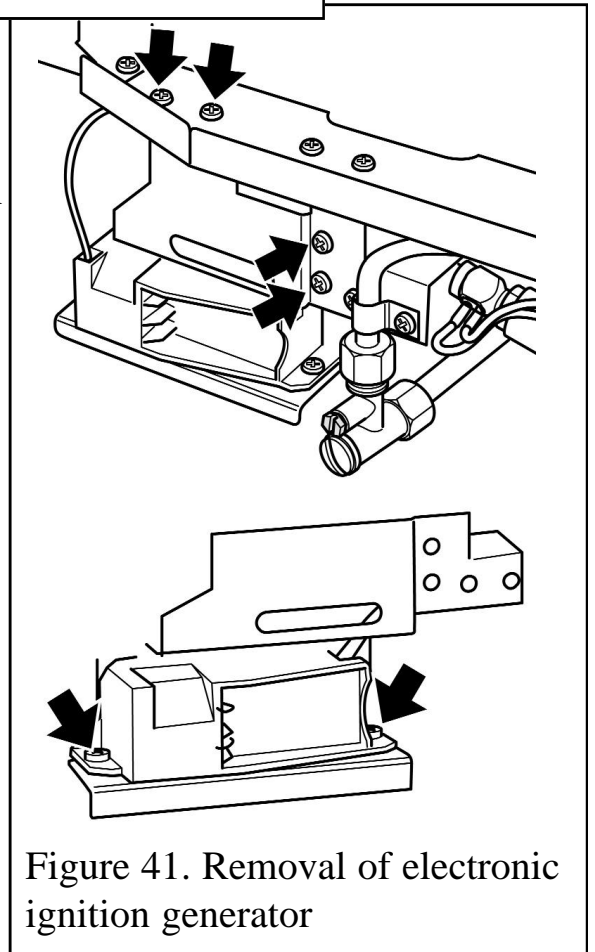

Figure 41. Removal of electronic ignition generator

INSTALLER GUIDE

16.9 To remove the thermocouple interrupter block.

(See figure 35).

1. Remove the burner unit (See section 16.7).
2. Detach the thermocouple from the interrupter block by unscrewing the thermocouple nut.
3. Detach the two microswitch leads from the interrupter block.
4. Remove the interrupter block by unscrewing from the gas shut-off tap.
5. Refit in the reverse order. If the microswitch leads cannot be easily attached to the interrupter block when it is fully tightened to the gas shut-off tap, slacken it and rotate to allow the leads to be fitted. Retighten making sure that the leads remain in place in the interrupter block. Fit and tighten the thermocouple nut making sure that the leads are secured in the interrupter block to give a good electrical contact.

16.10 To remove the pilot unit.

1. Remove the burner unit (See section 16.7).
2. Detach the pilot pipe from the pilot unit.
3. Detach the thermocouple from the interrupter block by unscrewing the thermocouple nut.
4. Detach the electrode lead from the underside of the electrode tab.
6. Remove the two screws securing the pilot unit (See figure 42).
7. Refit in the reverse order.

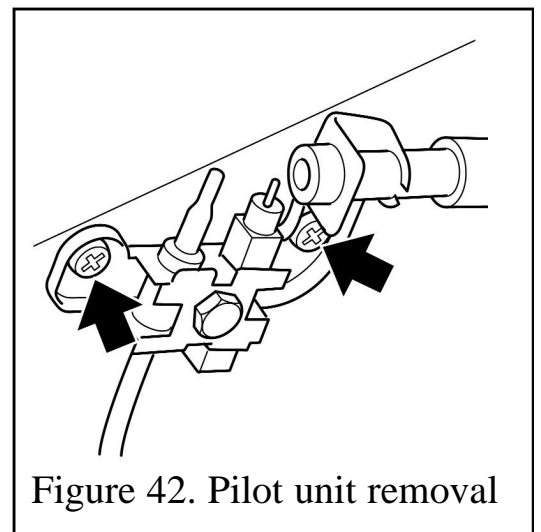

Figure 42. Pilot unit removal

Note:

1. *The pilot unit is an atmosphere sensing device. It must be replaced as a whole assembly. Its individual components are not separately replaceable.*
2. *When the thermocouple is removed from the interrupter block, the microswitch lead terminals in the interrupter block will be loose. Make sure that they are properly secured to give a good electrical contact when retightening the thermocouple nut.*

16.11 To remove the shut-off tap.

(See figure 43).

1. Remove the burner unit (See section 16.7).
2. If lying the burner on its back, ensure that the work surface is suitably protected. This will avoid damage to the work surface. Turn the burner unit upside down. Detach the thermocouple and interrupter block from the tap (See section 16.9 paragraphs 2 - 4).
3. Detach the pilot pipe from the tap.
4. Detach the inlet pipe.
5. Remove the hexagonal nut securing the tap to the mounting bracket.
6. Detach the elbow by unfastening the hexagonal nut connecting it to the flow rate

INSTALLER GUIDE

controller. Lift the tap (complete with elbow) clear.

7. Loosen the hexagonal locknut securing the elbow to the tap. Remove the elbow by rotating it.

8. If fitting a new tap, remove the hexagonal nut at the mounting bracket end of the old tap and fit to the replacement tap. Refit in the reverse order. When refitting, make sure that the tap spindle is in the correct relationship relative to the control pivot bracket. Rotate the pivot bracket fully clockwise. The tap spindle should “bottom out” (i.e. the tap should be fully open) after the pivot

bracket has actuated the ignition microswitch but before it has pushed the microswitch leaf against the microswitch body.

When refitting the thermocouple and interrupter block, make sure that the microswitch wires are properly secured to give a good electrical contact.

16.12 To remove the gas flow rate controller .

(See figure 44).

1. Remove the burner unit (See section 16.7).

2. If lying the burner on its back, ensure that the work surface is suitably protected This will avoid damage to the work surface.

3. Detach the microswitch cover (See section 16.2 paragraph 2).

4. Detach the shut-off tap as detailed in section 16.11 paragraphs 2-6.

5. Detach the burner pipe from the controller. Support the controller while detaching to prevent excessive strain.

6. Remove the nut and washer securing the control pivot bracket to the controller at the front. Support the pivot bracket while removing the nut to prevent possible damage to the microswitch.

7. Remove the hexagonal bolt securing the control pivot bracket to the controller at the rear.

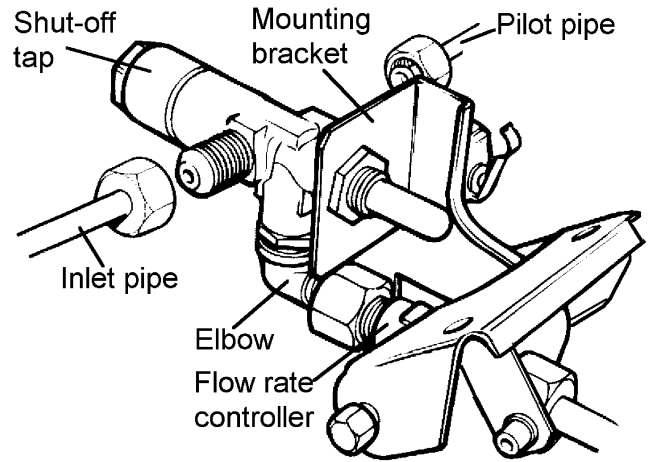

Figure 43. Shut-off tap (Viewed from rear with burner turned over)

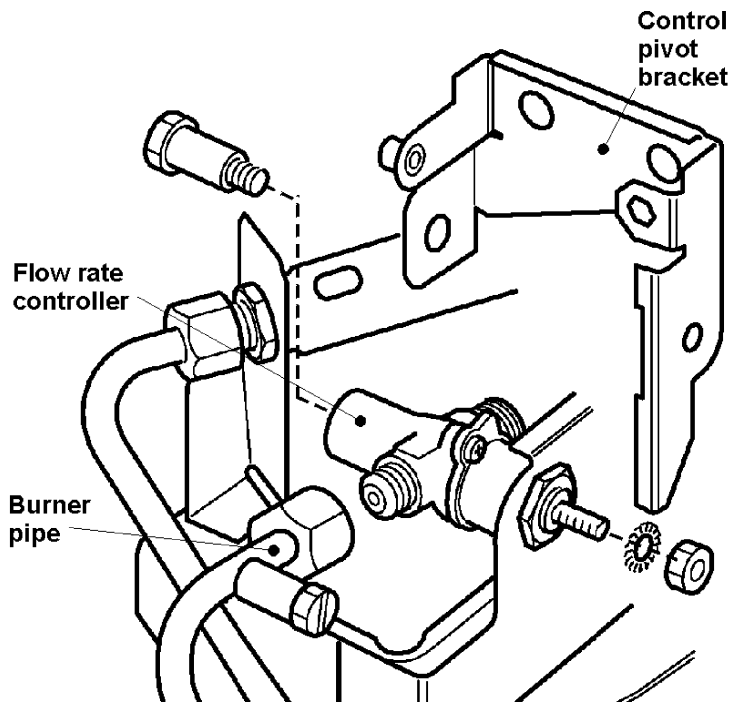

Figure 44. Flow rate controller

INSTALLER GUIDE

8. Detach the control pivot bracket.
9. Remove the hexagonal nut securing the controller to the front mounting bracket and remove the flow rate controller.
10. Refit in the reverse order.

16.13 To replace the burner.

(See figure 45).

1. Remove the burner unit (See section 16.7).
2. Support the elbow injector and unscrew the injector nut.
3. Remove the two screws from the burner clamping plate (See figure 45).
4. Lift the right hand side of the burner, slide it to the right and lift clear
5. Refit in reverse order.

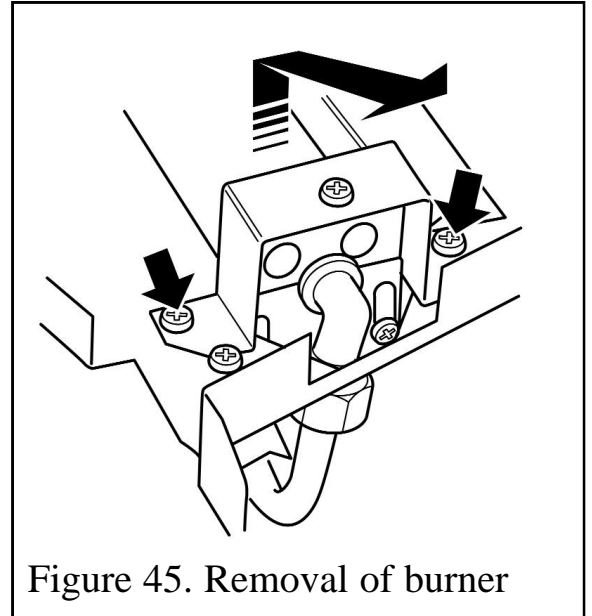

Figure 45. Removal of burner

16.14 To remove the main burner injector.

(See figure 46).

1. Remove the burner (See section 16.13).
2. Remove the burner clamping screw (See figure 46).
3. Unscrew the injector from the burner
4. Refit in the reverse order.

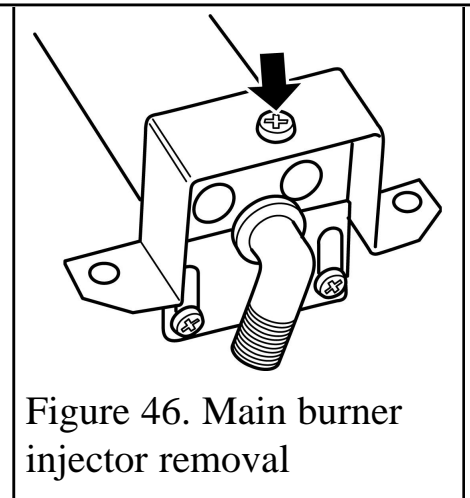

Figure 46. Main burner injector removal

16.15 To remove the appliance from the fireplace.

1. Remove the burner unit (See section 16.7).
2. If the fire retention is as method 1 (See section 9.1 of installation instructions), remove the screws.
If the fire retention is as method 2 (See section 9.2 of installation instructions), slacken the hexagonal adjusters on the cable retainers and unscrew the thumbscrews to release the cables.
3. Refit as described in the relevant installation sections. Make sure gas soundness, sealing, spillage test and performance are satisfactory.