

HI-SPEC J25 WARM AIR HEATERS

SYSTEM E-T and Basic Control

INSTALLATION, COMMISSIONING & SERVICING INSTRUCTIONS

G.C. No 42 451 04

Publication No. ZZ 753/12
January 2010

This appliance has been tested and certified by G. L. Industrial Services UK Ltd. for use with natural gas G20.

Note: If a HIJAN 6 or SUPERJAN 6 circulator is fitted, the relevant Installation, Commissioning and Servicing instructions provided with that appliance must also be observed.

1. BRIEF DESCRIPTION

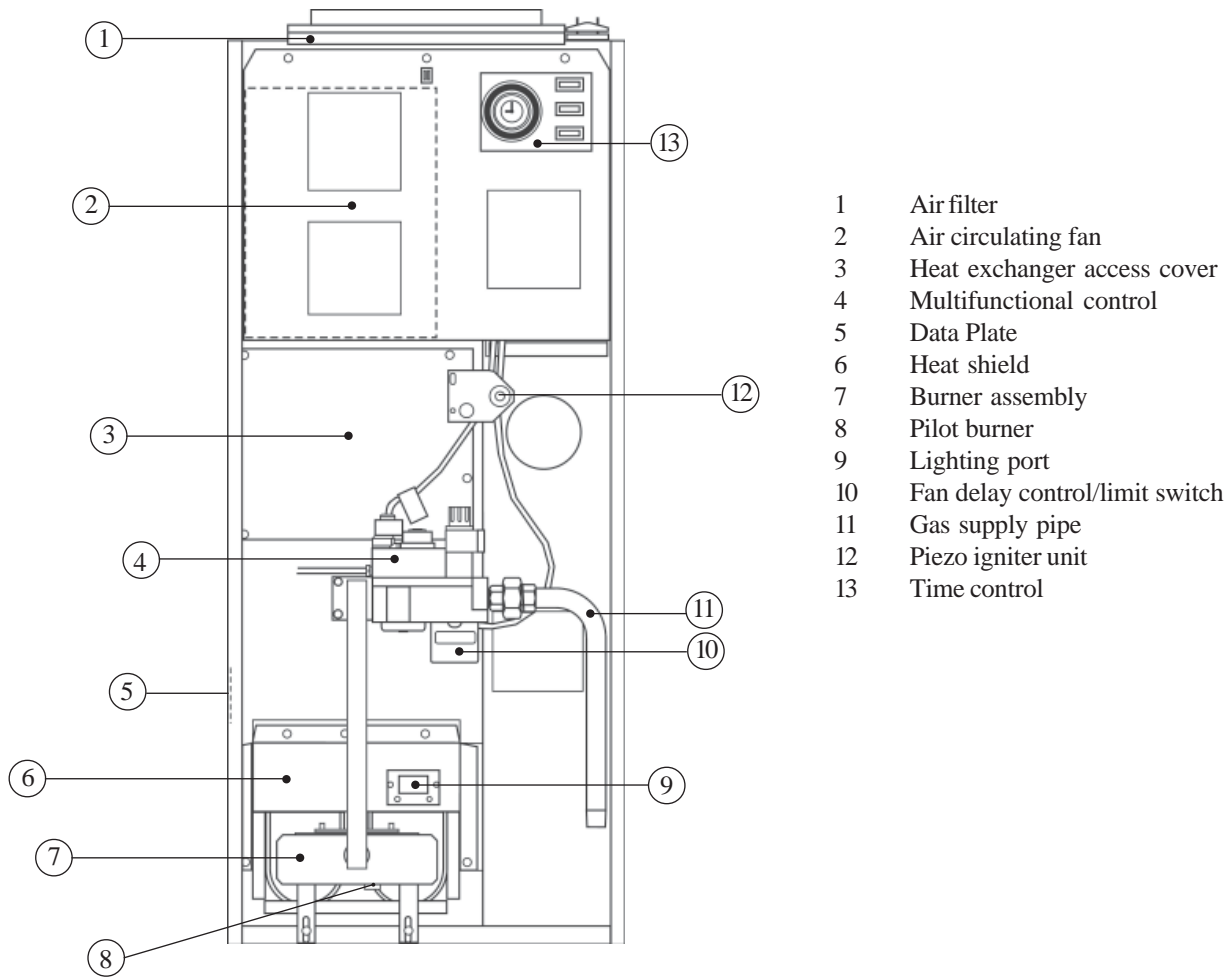

Fig. 1

- 1.1 HI-SPEC J25 is an open-flued, fan assisted downflow, ducted warm air heater, which may be supplied with SYSTEM E-T or Basic control. A HIJAN 6 or SUPERJAN 6 circulator is available as an option. A pilot burner incorporating an Atmospheric Sensing Device (ASD) is fitted which responds to the presence of flue gases and shuts down the appliance.
- 1.2 The Air heater output can be adjusted between 5.6kW (20.0MJ/h, 19,000Btu/h) and 7.3kW (26.4MJ/h, 25,000Btu/h). "Summer air circulation" of unheated air is available by manual selection (see User's Instructions). HIJAN 6 output is 3.81kW (13.7MJ/h, 13,000Btu/h), whilst SUPERJAN 6 output is 6.0kW (21.6MJ/h, 20,470Btu/h).

THIS APPLIANCE CONFORMS TO BS EN 45014

Installation shall be in accordance with the current editions of:

Building Standards (Scotland) (Consolidation) Regulations
Building Regulations
Gas Safety (Installation and Use) Regulations (as amended)
BS7671 Institute of Electrical Engineers (I.E.E.) Wiring Regulations
BS6891 Installation of Low Pressure Gas Pipework of up to 28mm (R1) in domestic premises (2nd family gases).
BS5440 Pt.1 (Flues for Gas Appliances)
BS5440 Pt.2 (Air Supply for Gas Appliances)
BS5864 Installation of Gas Fired Ducted Air Heaters
British System Design Manual “Gas Fired Warm Air Heating”
Model and Local Authority Bye-laws
BS5546 Installation of Domestic Hot Water Supplies.

IMPORTANT: STATUTE LAW DEFINES THAT ALL GAS APPLIANCES MUST BE INSTALLED BY COMPETENT PERSONS, (i.e. GAS SAFE REGISTERED INSTALLERS) IN ACCORDANCE WITH THE GAS SAFETY (INSTALLATION AND USE) REGULATIONS (CURRENT EDITION). FAILURE TO COMPLY WITH THESE REGULATIONS MAY LEAD TO PROSECUTION.

2. HEATER COMPARTMENT AND CLEARANCES (SEE BS5864)

- 2.1 **IMPORTANT:** If the heater is to be fitted to an existing base duct (warm air plenum), always ensure that installation is carried out such that the rear left hand corner of the heater is aligned with the rear left hand corner of the base duct, so that any overhang or blanking off will be at the front and/or right hand side. In any event, blanking plates must be mechanically secured and all joints sealed.
- 2.2 When the heater is fitted into a compartment, a minimum clearance from the compartment walls of 15mm at the sides and rear, and 25mm at the front must be left. Consideration should also be given to the space required for the removal and replacement of the filter tray and the entry of the gas and electrical supplies.
- 2.3 For service access, a minimum of 450mm (18ins) is required at the front of the heater. Space must also be allowed, in a compartment installation, to permit the removal of the heater. The clearance between the appliance and the compartment should be not less than 75mm (3 in). However, if clearances are less than 75mm, the internal surface of the compartment must be lined with non-combustible material. The compartment must be of a fixed rigid structure.
- 2.4 In airing cupboard installations, the part used as the air heater compartment must comply with the relevant section of BS5864 and must be completely separated by either a non-combustible partition or a perforated metal partition with the perforations not exceeding 13mm (1/2in). The secondary flue must be a tight fit where it passes through the partition and must be suitably protected (see BS5440: Part 1).
- 2.5 In under-stairs installations, the compartment must comply with the relevant section of BS5864, provided that in addition, all internal surfaces, including the base, are non-combustible or lined with non-combustible material. This requirement is applicable only to dwellings of more than two storeys.
- 2.6 If the Air Heater is to be installed onto a combustible surface, a suitable base tray (BT25) is required. However, when a base duct is used, this provides sufficient protection for combustible material and no further insulation is required.

3. VENTILATION AND COMBUSTION AIR

- 3.1 The room or internal space in which the heater is installed requires a permanent air vent of minimum effective area 36cm² (5in²). The air vent should be either direct to outside air or to an adjacent room or internal space (other than a toilet or bathroom) that itself has an equivalent air vent direct to outside.
- 3.2 Combustion air may be introduced, via a 100mm (4in) nominal bore pipe, connected to a return air duct or plenum from a ventilated area and fitted with a lockable damper. The damper should be adjusted to control combustion airflow to 0.0083m³/s (17.6cfm), (i.e. 1.06m/s [210ft/min] velocity in a 100mm [4in] bore pipe). If this arrangement is used, a non-closeable warm air register **MUST** be provided in the same area as the front of the air heater or heater compartment if a return air grille is not located in that area.
- 3.3 When installed in a compartment, two permanent ventilation openings into the compartment are required, one at high level and one at low level, both communicating either directly with outside air or with a ventilated room or space. The minimum effective areas specified in Table 1 are related to the rated heat input of the Air Heater, and assuming that a HIJAN 6 circulator is fitted. If a SUPERJAN 6 circulator is fitted, the minimum area is greater, and reference made to the relevant installation instructions for the circulator.
- 3.4 If any room or area from which air is drawn for ventilation or combustion contains an extract fan, the permanent vents must be sized to ensure that the operation of the appliance(s) at full rate is/are not adversely affected. A spillage test as specified in sub-para 6.8 (Safety Checks) is carried out and any remedial work undertaken.

Ventilated from inside building.	Low level grille	284cm ² (44in ²)
	High level grille	142cm ² (22in ²)
Ventilated from outside building.	Low level grille	142cm ² (22in ²)
	High level grille	71cm ² (11 ²)

Table 1: Minimum Effective Areas

4

DUCT SYSTEM

(See British Design Manual- Gas Fired Warm Air Heating)

4.1 RETURN AIR

- 4.1.1 It is NOT recommended that the return air duct be routed directly from the main living area, but from a convenient central area serving the remainder of the dwelling.
- 4.1.2 All return air shall be POSITIVELY ducted from outside the compartment to the top of the unit via a return air duct. Where required, return air can be ducted to the side of the heater by transferring the return air spigot. Referring to fig. 9 (page 25), remove the 4 x knockouts and use the return air spigot as a template in order to mark out where to cut the heater casing. Using a 2.9 mm bit, drill the fixing holes and secure using the previously removed screws. Fit the supplied blanking plate to the top of the heater and secure using the screws supplied with the blanking plate. **NB remove swarf from the air heater compartment prior to installation and commissioning!**
- 4.1.3 The return air system should be constructed of fire-resistant material. The flue shall not be run through an area serving as a return air path. It is extremely important that the correct size of return air grilles and ducting is used. For heaters on maximum output the return air duct size should not be less than the equivalent of 200mm x 200mm (8" x 8"). If flexible duct is used the duct diameter should not be less than 250mm (10") dia. The return air grille should have a free area of not less than 645cm² (100in²).
- 4.1.4 An adequate and unobstructed return air path is essential from areas not served by a directly ducted return and to which warm air is delivered. All such rooms should be fitted with relief grilles which have a free area of 0.0088m²/kW (1in²/250Btu/h) of heat supplied to the room. The only exceptions are kitchens, bathrooms and WC.'s.
- 4.1.5 The return air duct should allow for ease of removal for access to the flue.
- 4.1.6 All duct work in the room or internal space in which the heater is installed shall be mechanically secured, and sealed with ducting tape.

4.2 WARM DELIVERED AIR

- 4.2.1 All duct work, including riser ducts, should be fully insulated with 50mm (2in) fibreglass or similar. If short extended duct runs are taken below floor level these should be similarly insulated, and in addition wrapped with a sound vapour proof barrier, and protected from crushing.
- 4.2.2 The duct system should be carefully designed (as given in the guidelines in the British System Design Manual) to suit the needs of its specific heating requirements and building layout. The type of duct system, (i.e. radial/extended plenum/stepped) should be installed using the least number of fittings to minimise airflow resistance. The base duct, which equalises the air pressure to supply ducts, shall be constructed to support the weight of the heater, which shall be secured to the plenum with screws on at least two sides, and sealed using self-adhesive foam strip, ducting tape or sealing compound. All ducting and blanking plates shall be mechanically secured and sealed.

5.

INSTALLATION REQUIREMENTS

Note: For circulator Installation Instructions, refer to the relevant instructions provided with the circulator.

5.1 FLUES (SEE BRITISH STANDARDS BS5440 PT.1 FLUES)

- 5.1.1 All joints shall be soundly sealed.
- 5.1.2 The flue should be kept as short and warm as possible.
- 5.1.3 Sufficient support brackets shall be installed to bear the weight of the total flue system.
- 5.1.4 The spigot connection of the heater draught diverter will accept internally the spigot end of a non-asbestos flue to BS567 or twin wall metal flue to BS715 of nominal 100mm (4in) diameter.

- 5.1.5 A split collar should be fitted to provide for flue maintenance or inspection.
- 5.1.6 The flue shall be in accordance with the Building Regulations and British Gas Materials and Installations specification (3rd edition) with regard to clearance and shielding from combustible materials.
- 5.1.7 All materials shall be in accordance with Building Regulations requirements.
- 5.1.8 The flue should run as vertically as possible. Horizontal runs should be avoided if at all possible and any directional change should be as gentle as possible. If there is any doubt about the flue configuration, the equivalent flue height should be determined (see 5.1.10).
- 5.1.9 If the appliance to be fitted is a replacement, the old appliance should be checked for signs of spillage prior to commencement of the installation and appropriate action taken, (i.e. check flue system and renew as necessary).
- 5.1.10 It is recommended that at least 600mm of vertical flue should be provided from the top of the draught diverter (for new installations this shall be incorporated into the flue design). However, when carrying out replacement installations, an existing flue system may be encountered, where the vertical flue above the appliance to the first bend is less than 600mm. In the first instance, the installer must judge whether this distance can be achieved practicably by some means. Where this is not practicable, the existing flue system may be used, providing there is no evidence of spillage from the old appliance (see 5.1.9 above). Every effort must be made, however, to ensure that the existing flue complies in every other way to BS 5440 Part 1, including the visual inspection, flue flow and spillage test described in 4.3.2 of the above standard. Flue configurations may be assessed in terms of equivalent vertical height - details are given below. For air heaters, the minimum equivalent vertical height is 1 metre. The installer must make a judgement based on his knowledge and experience and the examination and testing described above as to whether an existing flue system can be used.

Note: Ventilation of the compartment, room or internal space in which the appliance is to be installed must be checked for compliance with the requirements of BS 5440 Part 2, (Ref. Section 3 of these instructions) and upgraded as necessary.

5.1.11 Calculation method for flue sizing: (BS 5440: Part 1, Appendix A)

- a. This appendix provides a procedure for estimating whether a given flue design is likely to ensure full clearance of combustion products.
- b. The procedure is based on calculating the ‘equivalent height’ of the flue under consideration, i.e. that height of the straight vertical circular flue pipe of specific size which will produce the same flow rate as the flue under consideration. The equivalent height is calculated from the formula:

$$H_e = H_a \times \frac{(K_i + K_o)_e}{(K_i + K_o)_a - K_e H_a + \text{Sum K}}$$

where:

H_e is the height of the equivalent flue;

H_a is the vertical height of the actual or proposed flue;

K_i is the inlet resistance of the flue;

K_o is the outlet resistance from the flue;

subscript e refers to the equivalent flue diameter;

subscript a refers to the actual or proposed flue diameter;

K_e is the resistance per unit length of the equivalent flue;

Sum K is the resistance (other than the inlet and outlet resistance) of the actual or proposed flue.

Note: K and Sum K are obtained from Table 2. K_o and K_i are obtained from Table 3.

- c. Table 2 gives resistance factors for common flue components for use in the formula. Table 3 contains the appropriate inlet and outlet flue resistances. The flue is likely to be satisfactory if its equivalent height exceeds 1m.

d. Worked Calculation Example:

A warm air unit with a 100 mm diameter flue spigot, fitted with a pre-fabricated flue system leading to a ridge tile in the loft (refer Fig. 2):

From table 3:

K_{ia}	Inlet resistance of actual flue	2.5
K_{oa}	Outlet resistance of actual flue	2.5
K_{ie}	Inlet resistance of equivalent flue	2.5
K_{oe}	Outlet resistance of the actual flue . . .	2.5

Component	Internal Size (mm)	Resistance	Components	Internal Size (mm)	Resistance
Flue Blocks	197 x 67	0.85 per metre	45° bend	100mm pipe	0.61 per fitting
	231 x 65	0.65 run		125mm pipe	0.25 per fitting
	317 x 63	0.35		150mm pipe	0.12 per fitting
	140 x 102	0.60		197 x 67	0.30 per fitting
	200 x 75	0.60		231 x 65	0.22 per fitting
	183 x 90	0.45		317 x 63	0.13 per fitting
Pipe	100	0.78	Raking Block	Any	0.30 per block
	125	0.25			
	150	0.12	Adaptor Block	Any	0.50 per block
Chimney	213 x 213	0.02	Terminal	100mm ridge	2.5
				125mm ridge	1.0
90° Bend	100mm pipe	1.22 per fitting		150mm ridge	0.48
	125mm pipe	0.50 per fitting		100mm GCI	0.6
	150mm pipe	0.24 per fitting		125mm GCI	0.25
				150mm GCI	0.12

Table 2
Resistance factors for use in calculating equivalent lengths

Appliance	Inlet Resistance (K _i)	Flue	Outlet resistance (K _o)
100mm Dia Spigot	2.5	100mm	2.5
125mm Dia Spigot	1.0	125mm	1.0
150mm Dia Spigot	0.48	150mm	0.48

Table 3
Inlet and outlet resistance

From table 2:

Other resistances of actual flue:

Terminal	2.5
Pipe bend (2 x 0.61)	1.22
Pipe (4 x 1m @ 0.78)	3.12
(5 x 0.3m @ 0.78)	1.17
Sum K	8.01

Equivalent height :

From the formula

$$H_e = 6.2 \times \frac{(2.5 + 2.5)}{(2.5 + 2.5) - (0.78 \times 6.2) + 8.01}$$

H_e = 3.793 This flue exceeds 1.0m equivalent height and is therefore satisfactory.

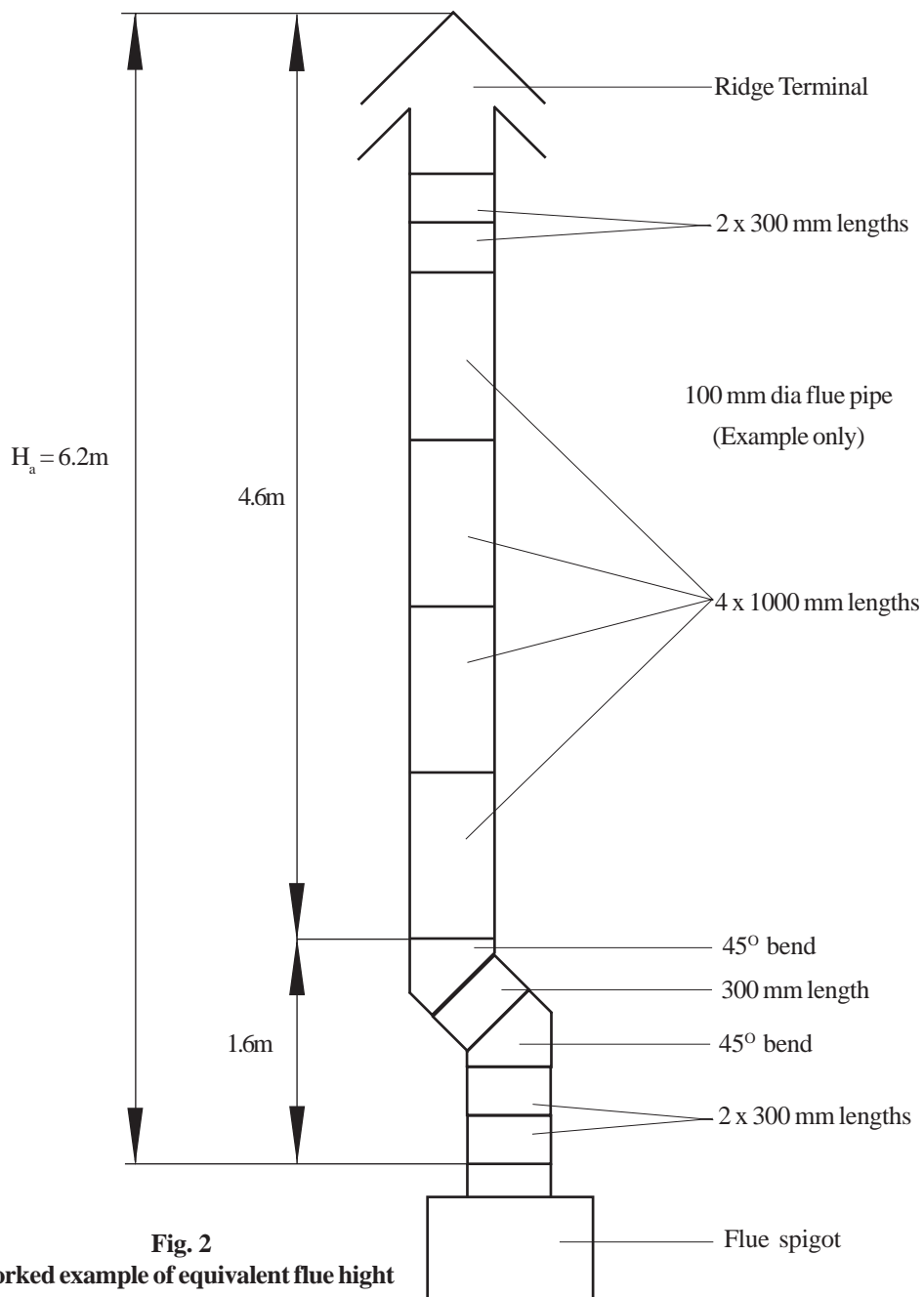

Fig. 2
Worked example of equivalent flue height

Note: Ventilation of the compartment, room or internal space in which the appliance is to be installed must be checked for compliance with the requirements of BS 5440 Part 2 (Ref. Section 3 of these instructions) and upgraded as necessary

5.1.12 Consideration must be given to external flues with a view to prevention of condensation and weathering problems.

5.1.13 An approved terminal should always be used; a ridge terminal or “GC1” terminal is specifically recommended. The latter should be positioned in a free air space where it is not shielded by any structure. A minimum of 1m (3ft.) from any vertical or inclined roof structure must be allowed for.

5.1.14 Where flue blocks are used, builders should ensure that no obstruction is created during erection. The installer should ensure that the connection flue does not project beyond the internal wall of the flue blocks and that there is provision for examination and servicing.

5.1.15 **Important:** Before installing the appliance, carry out a visual check of the flue system as directed in the relevant section of BS5440 Pt.1, then check the flue performance as follows:

- a. close all doors and windows in the room in which the appliance is to be installed;
- b. introduce some heat into the flue, using a blow torch or other means;
- c. carry out a flow visualisation check with a smoke pellet at the intended position for the appliance. Ensure that there is discharge of smoke from the correct terminal only, and no spillage into the room. Smoke coming out of other than the correct terminal only, or a down draught or ‘no flow’ condition, indicates that the flue has failed the test, and the appliance shall not be connected until the defect has been found and rectified, and the test satisfactorily completed.

5.2 ELECTRICAL

5.2.1 Mains.

- a. The heater is supplied with mains cable (PVC sheathed, heat resisting to 85°C), 3-core Brown-Blue-Green/Yellow, 6A, 0.75mm²), connected to a terminal block and exiting through the heater at the right hand top. The cable is suitable for a 230V 50Hz supply and shall be connected to the fixed wiring using a double pole switched, fused spur, incorporating a protective earth link. The fuse fitted shall be rated 5A to BS1362. Connections shall be in accordance with the current edition of I.E.E Regulations BS 7671.
- b. The Fan Delay Control and Limit Switch are not adjustable and are set as follows:
 - i. Basic Models: Fan Delay Control closes at 54°C± 4.5°C; opens at 40°C±3°C.
 - ii. All Models: Limit Switch opens at 80°C; closes at 60°C.
- c. **SYSTEM E-T MODELS:** An electronic controller (Thermista-stat) is supplied which acts as a room thermostat.
- d. **BASIC CONTROL MODELS:** A 24V room thermostat (not supplied), that complies with BS800, BS3955 and BS4201 is essential to ensure close control of comfort conditions. An anticipator is located within the thermostat and is graded in amps. The anticipator should be checked and adjusted to 0.2A.

5.2.2 Thermista-stat/Room Thermostat and its location.

- a. The Thermista-stat/Room Thermostat should be located where there is free air circulation approx. 1.5m (5ft) from the floor.
- b. Avoid the following locations:
 - i. In a room where temperature is greatly affected by the sun or any other heat source, e.g. radiant fire, wall light fittings or TV set.
 - ii. Near an outside door or windows, or on an outside wall.
 - iii. Where affected by warm air ducts, diffusers, waste pipes or the heater itself.
 - iv. Where subject to vibration.
- c. Connect Thermista-stat/Room thermostat wires to control panel terminals '7' and '8' (see Fig. 7a/b or 8a/b).

5.2.3 IMPORTANT: SUPERJAN 6 circulator.

- a. If the air heater is fitted with a SUPERJAN 6 circulator, this will contain a pump overrun switch (CK6), which is connected via the air heater terminal block terminals '6', '10' and '12'. Ensure that the red wire link connecting terminals '10' and '12' has been removed, as this would cause the effective short circuit of the pump overrun switch.

5.3 GAS (SEE BS5864 AND BS6891)

- 5.3.1 An independent gas supply pipe from the meter is to be preferred wherever possible. When this is not possible, the pipe must be capable of taking the complete input of the heater and all other gas appliances being served by this same pipe. This supply should be suitably sized to conform to British Standards requirements of no more than 1.0 mbar (0.4in wg) pressure drop (See table of discharge in BS6891).
- 5.4.2 The 1/2in union gas cock (supplied) must be fitted to the gas inlet of the heater for easy isolation during servicing. The gas pipe should be so fitted and installed as to be durable, substantial and gas tight. To assist in determining where a gas connection may not be tight, a leak detection fluid should be applied around the connection. Under no circumstances should a flame be used to locate a gas leak. Gas entry to the air heater is through either side to a Rc1/2 (1/2in BSP. external [taper] thread).

5.4 DRAUGHT DIVERTER & DEFLECTOR PLATE:

- 5.4.1 The HI-SPEC J25 heater is supplied with a draught diverter that requires fitting to the rear of the heater prior to installation, using 3 x 4mm screws and lock washers (provided).
- 5.4.2 The deflector plate prevents spillage from the draught diverter in the event of a leak between the air heater and the base plenum and MUST be fitted as shown in fig 3 using the pre-drilled holes and the 2 x No8 screws provided.

5.5 DEFLECTOR PLATE SAFETY CHECK:

In order to ensure that the deflector plate is preventing warm air from entering the draught diverter and therefore causing spillage, the following test MUST be carried out BEFORE commissioning:

- 5.5.1 Turn on the power supply to the heater.
- 5.5.2 Set the summer airflow switch to "on".
- 5.5.3 Using a smoke match, introduce smoke into the heat exchanger at the burner opening.

- 5.5.4 Ensure that the smoke is drawn into the heat exchanger and not blown back from the burner opening.
- 5.5.5 If smoke is blown back from the burner opening, check for air leaks between the heater and the base plenum, paying particular attention to the rear of the heater directly beneath the draught diverter.

6. COMMISSIONING

6.1 PREPARATION:

- 6.1.1 Ensure that:
 - a. Gas and Electrical supplies are **OFF**.
 - b. Filter, fan and fan compartments are free from obstructions.
 - c. All registers or grilles are open and conform to design specifications.
 - d. Return, relief and ventilation air installations are adequate.

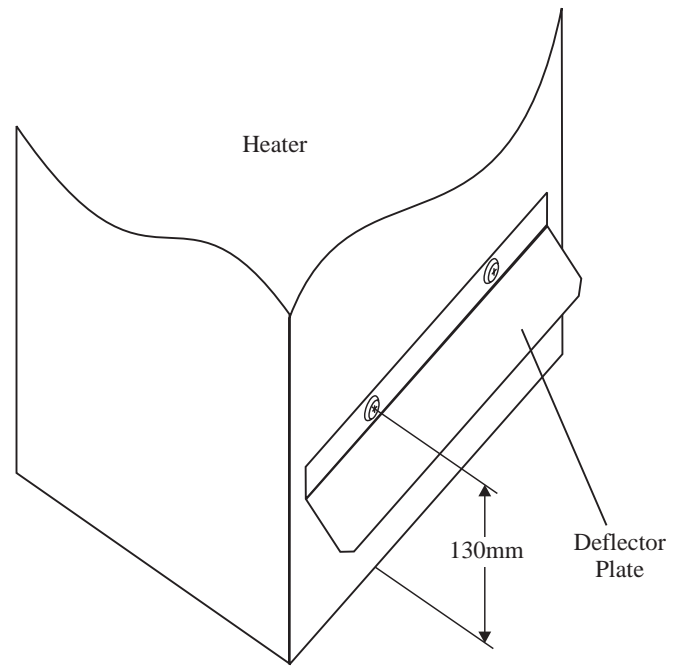

Fig. 3
Deflector Plate

6.2 SYSTEMBALANCING:

- 6.2.1 Set the Air Heater electrical supply **ON**.
- 6.2.2 Set the SUMMER AIRFLOW switch to '1'.
- 6.2.3 Balance the system to provide the required volume proportions at the warm air outlets.

Note: If the system includes ceiling diffusers, the air through these should be NOT LESS THAN 1.5m/s (300ft/min), except for very small rooms, (i.e., bathrooms etc.). Outlet faces may require partial blanking in order to achieve this.

6.3 IGNITION OF PILOT AND MAIN BURNERS:

WARNING: If the Pilot Bight is extinguished either intentionally or unintentionally, no attempt should be made to relight the gas for a minimum of 3 minutes. Ensure that the Electrical supply, time control and Selector switches are set to 'OFF'.

- 6.3.1 Set the Thermista-stat/room thermostat to its lowest or **OFF** setting.
- 6.3.2 On the Multifunctional Control, remove the Outlet Pressure test point cover, and fit a pressure test gauge (refer fig. 5).
- 6.3.3 Turn the heater Gas supply **ON**, test for gas soundness and purge the whole gas pipe as described in BS6891.
- 6.3.4 Referring to Fig. 5, partially depress the OPERATING CONTROL and set the control $\frac{1}{4}$ turn anti-clockwise to the 'SPARK' symbol. Press and hold the OPERATING CONTROL, and whilst observing the Pilot Burner, repeatedly press the Piezo igniter button until the Pilot Burner ignites.

Note: If the Piezo unit should fail to spark, the Pilot Burner may be lit by applying a lighted taper to the Pilot Burner whilst the OPERATING CONTROL is pressed and held.

- 6.3.5 After 20 seconds release the OPERATING CONTROL and let it spring out; ensure that the Pilot Burner remains alight. If the Pilot Burner extinguishes, rotate the OPERATING CONTROL clockwise to the '1' position and ensure that the OPERATING CONTROL is fully reset. Wait three minutes and repeat steps 6.3.4 and 6.3.5, holding the OPERATING CONTROL depressed for a longer period, until the Pilot Burner remains alight.
- 6.3.6 With the Pilot Burner lit, depress the OPERATING CONTROL and turn it to the position indicated by the flame symbol.
- 6.3.7 Ensure that the pilot flame envelops the thermocouple tip, if not, check that the pilot orifices and aeration port are free from obstruction. The pilot is factory set and is non-adjustable.
- 6.3.8 Set the air heater Electricity supply **ON**.
- 6.3.9 Set the Time Control to the required Heating On periods.
- 6.3.10 Set the Selector switch to 'TIMED'.
- 6.3.11 Set the Thermista-stat or room thermostat to **MAXIMUM**.
- 6.3.12 Ensure that the Main Burner has now ignited.

- 6.3.13 Test for gas leakage at the supply, Multifunctional Control, Pilot and Main Burners using a proprietary detection fluid, sealing any leaks found.
- 6.3.14 Allow the heater to operate for a minimum of 15 minutes to ensure stability.

6.4 MAINBURNER PRESSURE TEST:

NOTE: AIR HEATER BURNERS ARE FACTORY SET TO PROVIDE A NOMINAL HIGH RATE OUTPUT AS DETAILED IN SUB PARA 1.2

- 6.4.1 Referring to Table 4 and Fig. 5 below, ensure that the pressure test gauge indicates the correct burner pressure, resetting if required as follows:

At the Multifunctional Control:

- i. Remove the Burner Pressure Adjuster cover.
- ii. Set the Burner Pressure Adjuster to provide a pressure test gauge indication for the correct burner pressure as detailed in Table 4.
- iii. Refit the Burner Pressure Adjuster cover.

- 6.4.2 Apply the pressure set arrow to indicate the appropriate burner pressure on the data badge.

6.5 EXTINGUISHING OF PILOT AND MAIN BURNERS:

- 6.5.1 On the Multifunctional Control, rotate the OPERATING CONTROL clockwise to the '1' position and ensure that the OPERATING CONTROL fully resets and both Pilot and Main Burners are extinguished.

- 6.5.2 On the Multifunctional control, remove the pressure test gauge and refit the Outlet Pressure test point cover.

6.6 TEMPERATURE RISE CHECK:

- 6.6.1 Ignite the Pilot and Main Burners and allow 15 minutes for stability before continuing.
- 6.6.2 Check that the temperature rise across the heater is between 45°C - 55°C, setting the fan speed as follows:
 - i. SYSTEM E-T heaters: System E-T provides a fan speed corresponding to the above temperature rise, if the appliance is to be set to operate at the minimum rate and the ducting has been sized accordingly, set the 'RATE SWITCH' to 'MIN', thus reducing the fan speed.
 - ii. BASIC Control heaters, the fan speed is adjusted by selecting the fan speed at control panel (decrease voltage selection to decrease fan speed).

Note: Tapping 1 = 230V, Tapping 2 = 220V, Tapping 3 = 210V, Tapping 4 = 200V, Tapping 5 = 190V, Tapping 6 = 170V.

6.7 AUTOMATIC CONTROLS CHECK

- 6.7.1 Set the TIME CONTROL to 'ON'.
- 6.7.2 Turn the Thermista-stat or room thermostat slowly clockwise until the Main Burner ignites.
- 6.7.3 Ensure that the fan starts to operate after a short period (approx. 1-2 minutes).

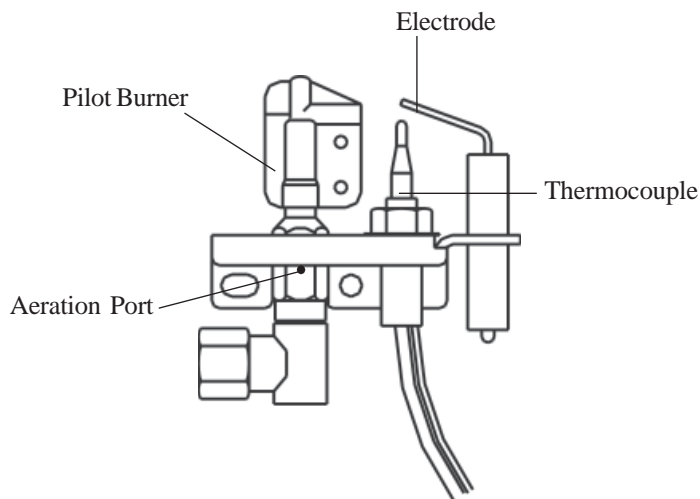
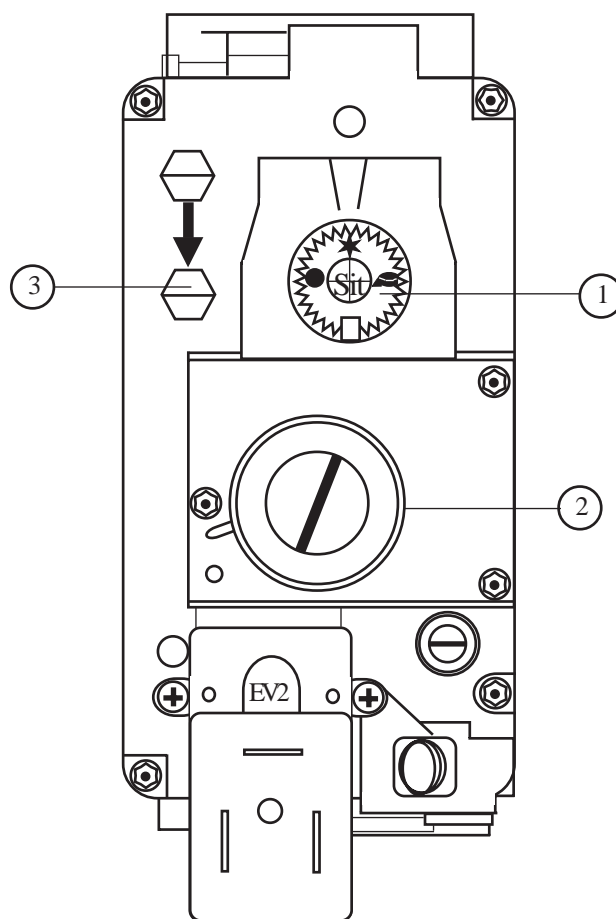

Fig. 4
Pilot Burner Assembly



- 1. Operating control
- 2. Burner pressure adjuster
- 3. Outlet pressure test point

Fig. 5
Multifunctional Control

SYSTEME-T models:

- 6.7.4 Ensure that the fan speed increases to full speed.
- 6.7.5 When the temperature reaches the control setting, check that the Main Burner cycles ON and OFF, at approximately 75 to 120 seconds.

BASIC CONTROL models:

- 6.7.6 When the temperature reaches the control setting, ensure that the Main Burner extinguishes followed by the fan switching off after a short period.
- 6.7.7 When the temperature falls below the control setting, ensure that the Main Burner re-ignites followed by fan operation.

6.8 SAFETY CHECKS:

- 6.8.1 Check for gas soundness within the appliance.
- 6.8.2 **Spillage test:** Carry out a full spillage test as follows, and ensure that the flue operates effectively with all doors closed and any extractor fans in operation.

NOTE: If an extractor fan is situated in an adjoining or adjacent room, carry out the spillage test with the interconnecting doors open.

If the draught diverter is accessible:

- a. Introduce smoke into the draught diverter adjacent to an exit from the heat exchanger, by means a smoke match or puffer.
- b. Ensure that there is no spillage present (indicated by displacement of smoke downwards and out of the draught diverter).

If the Draught Diverter is not accessible:

- a. Introduce smoke, by means of **part** of a smoke pellet on a non-combustible support, into the heat exchanger.
- b. Extinguish the Main and Pilot burners.
- c. Ensure that there is no spillage evident by visually observing the draught diverter location on the air heater.
- d. If spillage is evident, further investigation and rectification is required before re-testing the appliance.

WARNING: The appliance shall not be left connected to the gas supply unless it has successfully passed the above spillage test.

- 6.8.3 Turn OFF the gas supply at the service cock and ensure that the Multifunctional Control fail-safe operates within 60 secs (indicated by loud click from Multifunctional Control).
- 6.8.4 Turn gas supply ON at service cock.
- 6.8.5 Switch the appliance electrical supply OFF.
- 6.8.6 Disconnect the Air Circulation Fan at the flying lead socket.
- 6.8.7 Switch the appliance electrical supply ON.
- 6.8.8 Ignite the Pilot and Main Burners as detailed in 6.3.1 to 6.3.5.
- 6.8.9 Ensure that the Limit Switch operates, indicated by the Main Burner extinguishing, within 120 and 180 seconds.
- 6.8.10 Switch the appliance electrical supply OFF.
- 6.8.11 Reconnect the Air Circulation Fan.
- 6.8.12 Switch the appliance electrical supply ON.
- 6.8.13 Ensure that the Main Burner re-ignites when the appliance temperature reduces, (note: with the Air Circulation Fan disconnected, there may be some delay before the Main Burner re-ignites).

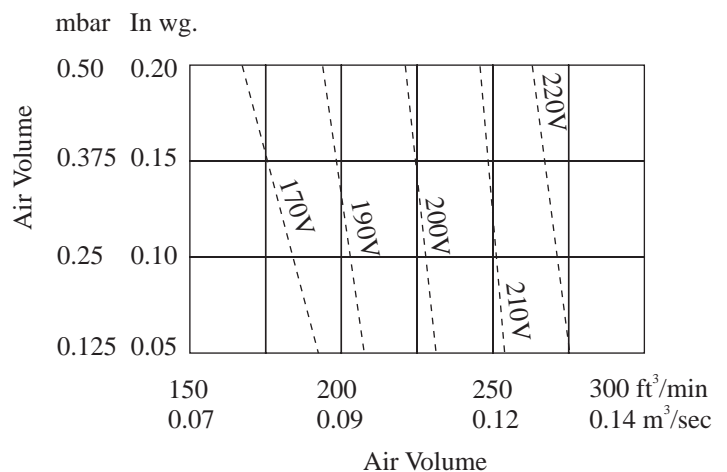

Table 5
Fan Performance Curve

	Low Rate			Medium Rate			High Rate		
	kW	MJ/h	Btu/h	kW	MJ/h	Btu/h	kW	MJ/h	Btu/h
Input	7.6	27.1	25,780	8.7	31.2	29,560	9.7	35.1	33,250
Output	5.6	20.0	19,000	6.5	23.2	22,000	7.3	26.4	25,000
Gas rate CV 1037Btu/ft ³	0.70 m ³ /h (24.9ft ³ /h)			0.80m ³ /h (28.5ft ³ /h)			0.91m ³ /h (32.1ft ³ /h)		
Burner setting pressure (hot)	10.0 mbar (4.0 in wg)			14.0 mbar (5.6 in wg)			17.0 mbar (6.8 in wg)		
Main injector	BRAY CAT 33/700								

**Table 4
Main Burner Pressure Settings**

7. INSTRUCTIONS FOR USERS

- 7.1 If the building is unoccupied, ensure that the Instructions for User are left taped to the air heater for the User, and the Installation Instructions are left at or near the air heater for use on future service calls.
- 7.2 If the building is occupied, hand the User Instructions over and ensure the User understands:
- 7.2.1 How to ignite the pilot and burner.
 - 7.2.2 How to operate the Thermista-stat/room thermostat, time and heater ON/OFF switch and summer air circulation switch, and that the time control must be reset following a power failure.
 - 7.2.3 How to extinguish the pilot and main burner at the Multifunctional control, and switch off electrical supply to the heater.
 - 7.2.4 How to remove, clean and refit the air filter and at what intervals (i.e. fortnightly, or for new houses, weekly).
 - 7.2.5 How to control the heating system by opening and closing warm air outlets.
 - 7.2.6 How to obtain summer air circulation.
 - 7.2.7 That the air grilles on the heater or heater compartment; grilles and ventilators in the walls, windows or doors of the building must not be obstructed.
 - 7.2.8 That the heater must be serviced at least once a year by a competent person to ensure efficient and safe operation.
 - 7.2.9 That the red instructions for safe use have been pointed out and understood.
 - 7.2.10 That expert help must be obtained if persistent failure of the pilot burner occurs.

8. MAINTENANCE

IMPORTANT: Ensure that the gas and electricity supplies are isolated before commencing any maintenance or replacement of components. After completion of any maintenance, always test for gas soundness and carry out a complete functional test of the appliance in accordance with the Commissioning Instructions at Sect 6.1 to 6.8 inclusive.

8.1 ROUTINE MAINTENANCE:

- 8.1.1 Operate the appliance and check for the correct function of the burner and controls.
- 8.1.2 Turn OFF the gas and electrical supplies to the appliance.
- 8.1.3 Remove the air heater front panel.
- 8.1.4 Remove and check the return air filter/cleaner for cleanliness, remove and clean the Air Circulation fan as detailed in para 8.7.

Note: During annual servicing, ASD pilots must be inspected for damage to any component part, the aeration port and lint arrestor must be cleaned to remove lint or debris. No attempt should be made to clean ASD pilots with any hard tool that could result in swarf or foreign bodies, since this can block the pilot injector, thereby affecting the safety performance. Upon ignition, both pilot flames should appear stable and 'clean', and the pilot assembly replaced if this is not so. If any damage is found, then the complete pilot assembly will require replacement.

- 8.1.5 Remove the Burner and Controls Assembly as detailed in para 8.2. Inspect and clean the main burner and injector as necessary. Examine the main burner for cracks, including hairline cracks, exchanging the burner as necessary.
- 8.1.6 Inspect and clear the Pilot Burner orifice.

- 8.1.7 Clean the heat exchanger flueways by thoroughly brushing from above and below.
 - 8.1.8 By viewing through the Fan Aperture, and using a torch or similar, examine the heat exchanger externally for signs of cracks or holes, particularly around welded joints.
 - 8.1.9 Using a torch or similar, introduce a light source into the heat exchanger burner aperture and upper access port, and again examine the heat exchanger for signs of cracks or holes, particularly around welded joints, whilst again viewing through the Fan Aperture.
 - 8.1.10 Refit the Air Circulation fan, Burner and Controls Assembly, and air filter/air cleaner.
 - 8.1.11 Light the appliance and note the main burner flame profile. If the flame profile is affected when the Air Circulation fan switches on, check for any air leaks between the air heater and the base plenum, paying particular attention to heaters with rear draught diverters. Rectify any air leaks before continuing with this procedure.
 - 8.1.12 Allow the air heater to operate for approximately 15 minutes to ensure stability, and with the main burner lit, ensure that the operation of Air Circulation fan does not affect the main burner flame profile.
- 8.2 **BURNER AND CONTROL ASSEMBLY REMOVAL:**
- 8.2.1 Ensure that the Gas and Electrical supplies are switched OFF
 - 8.2.2 Remove the appliance door.
 - 8.2.3 Disconnect the igniter at the Piezo unit.
 - 8.2.4 Disconnect the Multifunctional Control electrical connections.
 - 8.2.5 Disconnect the gas supply by breaking the union at the input side of the Multifunctional Control.
 - 8.2.6 Slacken the 2 lower Burner Assembly securing screws.
 - 8.2.7 Whilst supporting the Burner and Control Assembly, release the 2 upper Burner assembly fixing screws and withdraw the Burner and Control Assembly
 - 8.2.8 Refit the Burner and Control Assembly in reverse order.
- 8.3 **BURNER AND CONTROL ASSEMBLY CLEANING:**
- 8.3.1 Remove the Burner and Controls Assembly as detailed in 8.2.
 - 8.3.2 Disconnect the Pilot Feed Pipe and Thermocouple from the Multifunctional Control.
 - 8.3.3 Remove the lint arrestor from the Pilot Assembly, which is secured by a 'Terry clip'.
 - 8.3.4 Release the single screw securing the Pilot Assembly to the Burner and Controls Assembly, and remove the Pilot Assembly.
 - 8.3.5 Release the 3 nuts and lock washers securing the Main Burner to the mounting bracket, and remove the Main Burner.
 - 8.3.6 Release the 2 nuts securing the burner back plate and gasket, and withdraw back plate and gasket from the burner.
 - 8.3.7 Clean the burner thoroughly both inside and out with a soft brush. **DO NOT ENLARGE, DISTORT OR DAMAGE BURNER HOLES.**
 - 8.3.8 Reassemble in reverse order, replacing the burner gasket if damaged. The Pilot Assembly is located by a tag on the burner bracket. DO NOT over tighten the Thermocouple connection at the Multifunctional Control, (finger tight plus 1 flat).
- 8.4 **PILOT BURNER ASSEMBLY REMOVAL AND REPLACEMENT:**
- Note:** The relationship between the Pilot and Thermocouple is critical and must not be disturbed. Do not attempt to dismantle the Pilot Assembly. If any part of the Pilot Assembly is considered defective, the complete assembly must be replaced.
- 8.4.1 Remove the Burner and Controls Assembly as detailed in 8.2.
 - 8.4.2 Disconnect the Pilot Feed Pipe and Thermocouple from the Multifunctional Control.
 - 8.4.3 Remove the lint arrestor from the Pilot Assembly, which is secured by a 'Terry clip'.
 - 8.4.4 Release the single screw securing the Pilot Assembly to the Burner and Controls Assembly, and remove the Pilot Assembly.
 - 8.4.5 Disconnect the Pilot Feed Pipe from the Pilot Injector.
 - 8.4.6 Refitting or replacement is in reverse order. The Pilot Assembly is located by a tag on the burner bracket. DO NOT over tighten the Thermocouple connection at the Multifunctional Control, (finger tight plus 1 flat).

8.5 MULTIFUNCTIONAL CONTROL REMOVAL:

- 8.5.1 Remove the Burner and Controls Assembly as detailed in 8.2
- 8.5.2 Disconnect the Thermocouple at the Multifunctional Control, avoiding damage to the capillary.
- 8.5.3 Disconnect the Pilot Feed Pipe from the Multifunctional Control.
- 8.5.4 Disconnect Multifunctional Control input and output supply feeds.
- 8.5.5 Refitting or replacement is in reverse order.

NOTE: When refitting or replacing the Multifunctional Control, the 'O' ring seal is to be replaced.

8.6 PIEZO UNIT REMOVAL:

- 8.6.1 Disconnect the 2 conductors from Piezo unit.
- 8.6.2 Release the retaining nut and remove the Piezo unit from its mounting bracket.
- 8.6.3 Refitting or replacement is in reverse order.

8.7 AIR CIRCULATING FAN, REMOVAL AND CLEANING:

- 8.7.1 Ensure that the electrical supply is isolated.
- 8.7.2 Remove the appliance front door, release the 3 x securing screws and hinge down the fan chamber door.
- 8.7.3 Disconnect the fan flying leads from the Fan Assembly.
- 8.7.4 Release the Fan Assembly securing screw and withdraw the Fan Assembly from the Heater cabinet, avoiding damage to the fan blades.
- 8.7.5 Remove all dust from both the impeller and motor, taking care to not disturb the balance of the fan.
- 8.7.6 Refitting or replacement is in reverse order.

8.8 ELECTRICAL ASSEMBLY REMOVAL:

- 8.8.1 Ensure that the electrical supply is isolated.
- 8.8.2 Remove the appliance front door, release the 3 x securing screws and hinge down the fan chamber door.

SYSTEME-T models:

- 8.8.3 Disconnect the following
 - a. Air circulation fan flying leads from the capacitor,
 - b. 230V mains 'L', 'N' and 'E' from connection block terminals '1' and '2', and **Earth stud** respectively,
 - c. Thermosta-stat connections from connection block terminals '7' and '8',
 - d. Limit switch from connection block terminals '13' and '14',
 - e. Fan Delay Control from connection block terminals '18' and '17',
 - f. Multifunctional Control from connection block terminals '16 (N) and '15' (L),
 - g. Water heater from connection block terminals '10' (L) and '9' (N),
 - h. Water Pump from connection block terminals '12' (L) and '11' (N),
 - i. Cleanflow from connection block terminals '19' (24V) and '20' (0V),
 - j. Earth lead from the fan chamber floor,

BASIC Control models:

- 8.8.4 Disconnect the following:
 - a. Air circulation fan flying leads from the Fan assembly,
 - b. 230V mains 'L', 'N' and 'E' from connection block terminals '1' and '2', and **Earth stud** respectively,
 - c. Room thermostat connections from connection block terminals '7' and '8',
 - d. Limit Switch from connection block terminals '13' and '14',
 - e. Fan Delay Control from connection block terminals '18' and '17',
 - f. Multifunctional Control from connection block terminals '16 (N), '15' (L) and **Earth stud**.
 - g. Water heater from connection block terminals '10' (L) and '9' (N),
 - h. Water Pump from connection block terminals '12' (L) and '11' (N),
 - i. Cleanflow from connection block terminals '19' (24V) and '20' (0V),
 - j. Earth lead from the fan chamber floor,

Both model types:

- 8.8.5 Release the 2 x hinge pins and withdraw the Electrical Assembly, releasing wiring from cable clamps and grommets as required.
- 8.8.6 Refitting or replacement is in reverse order.

8.9 **ELECTRONIC MODULE REMOVAL (SYSTEME-T models only):**

- 8.9.1 Ensure that the electrical is isolated.
- 8.9.2 Remove the appliance front door, release the 3 x securing screws and hinge down the fan chamber door.
- 8.9.3 Disconnect terminals '21' to '33' from the Electronic Module.
- 8.9.4 Release the 2 x screws and nuts securing the Electronic Module to the Electrical assembly and remove the module.
- 8.9.5 Refitting or replacement is in reverse order.

8.10 **TRANSFORMER REMOVAL (BASIC Control models only):**

- 8.10.1 Ensure that the electrical is isolated.
- 8.10.2 Remove the appliance front door, release the 3 x securing screws and hinge down the fan chamber door.
- 8.10.3 Disconnect the conductors from the large Transformer.
- 8.10.4 Release the 2 x screws and nuts securing the Transformer to the Electrical Assembly, and remove the Transformer.
- 8.10.5 Refitting or replacement is in reverse order.

8.11 **TIME CONTROL and SWITCH REMOVAL:**

- 8.11.1 Ensure that the electrical is isolated.
- 8.11.2 Remove the appliance front door, release the 3 x securing screws and hinge down the fan chamber door.

Time Control removal:

- 8.11.3 Disconnect conductors 'C1', 'C2', 'C3' and 'C5' from the Time control.
- 8.11.4 Release the 3 x fixing screws, and withdraw the Time control.
- 8.11.5 Refitting or replacement is in reverse order.
- 8.11.6 Set the Time Control to the required ON and OFF times.
- 8.11.7 Set the Time Control to the correct time.

Switch removal:

- 8.11.8 Disconnect the conductors from the switch terminals.
- 8.11.9 Depress the retaining clips and press the switch out of the fascia panel.
- 8.11.10 Refitting or replacement is in reverse order.

WARNING: The fascia panel is held in place by push fit retainers which must be removed with caution to avoid causing damage to the support pins. Removal of the fascia is not advised unless it is intended to be replaced.

8.12 **FAN DELAY CONTROL/LIMIT SWITCH REMOVAL:**

- 8.12.1 Ensure that the electrical supply is isolated.
- 8.12.2 Remove appliance front door, release the 3 x securing screws and hinge down the fan chamber door.
- 8.12.3 Disconnect the following at the Electrical Panel:
 - a. Limit Switch from connection block terminals '13' and '14',
 - b. Fan Delay Control from connection block terminals '18' and '17',
 - c. Earth connection from common earth stud.
- 8.12.4 Release 2 x 4mm screws securing Limit switch mounting plate, and withdraw the control from the appliance by drawing the conductors through the grommet in the fan chamber floor.
- 8.12.6 Refitting or replacement is in reverse order.

8.13 **HEAT EXCHANGER ACCESS:**

- 8.13.1 Ensure that the electrical supply is isolated.
- 8.13.2 Remove the appliance front door.
- 8.13.3 Remove the Burner and Controls Assembly as detailed in sect 8.2.
- 8.13.4 Release the 6 screws securing the access plate to the bulkhead, and withdraw the access plate and gasket.
- 8.13.5 Release the 8 screws securing the top access cover plate, and withdraw the cover plate and gasket.
- 8.13.6 Reassembly is in reverse order.

NOTE: When reassembling, ensure that the baffles are pushed fully home, the gaskets are soundly sealed, and fully re-commission the heater.

9.

DEFECT DIAGNOSIS

9.1 **IMPORTANT:** If an electrical defect occurs after installation of the appliance; preliminary earth continuity, polarity, and resistance to earth checks should be carried out with a multimeter. On completion of any maintenance/fault-finding task that has required the breaking and remaking of electrical connections, then checks of continuity, polarity, and resistance to earth must be repeated.

9.2 **WARNINGS:**

9.2.1 When purging or checking gas supplies, ensure that the ventilation to the room or cupboard is adequate, and that all naked lights are extinguished.

9.2.2 If a defect occurs concerning the Pilot Burner, Thermocouple or Igniter Electrode, then the complete Pilot Assembly **MUST** be replaced.

9.2.3 **SYSTEME-T models:**

- a. When carrying out any electrical testing, a test meter **MUST** be used, since low resistance test devices can cause damage to the Electronics module.
- b. Before commencing defect diagnosis, ensure that the Thermista-stat is set to maximum, mains supply is 'ON' and that the time control is at an 'ON' position.
- c. Care is to be taken during the replacement and handling of electronic assemblies (i.e. electronic panel, airflow sensor or Thermista-stat). It is not practical to rectify defects on these assemblies, except at the manufacturer, and any attempt to do so may render the guarantee or factory replacement arrangement invalid.

	SYMPTOM	POSSIBLE CAUSE	REMEDY
a.	Pilot will not light.	<ol style="list-style-type: none"> i. No gas supply to heater. ii. Gas supply pipe not purged. iii. Pilot orifice restricted. iv. Pilot aeration port obstructed. v. Piezo system faulty. vi. Excessive gas supply pressure. 	<p>Check for gas at inlet pressure test point on Multifunctional Control.</p> <p>Purge gas supply pipe in accordance with BS 6891.</p> <p>Clear pilot orifice or replace pilot assembly.</p> <p>Clear obstruction or replace pilot assembly.</p> <p>Check igniter, lead, and electrode.</p> <p>Check that mains gas pressure is 20mbar, and reduce if necessary.</p>
b.	Pilot lights but goes out on releasing START button during initial light-up, or after normal operation.	<ol style="list-style-type: none"> i. Connection between thermocouple and Multifunctional Control not secure. ii. Faulty Multifunctional Control. iii. Faulty thermocouple. iv. Pilot flame affected by draught. v. Combustion air contaminated. 	<p>Check connection is secure.</p> <p>Replace Multifunctional Control.</p> <p>Replace Pilot Assembly.</p> <p>Eliminate draught.</p> <p>Carry out spillage test and rectify.</p>
c.	Main burner operating intermittently with fan running.	<ol style="list-style-type: none"> i. Gas rate or burner pressure setting high. ii. Temperature rise excessive. iii. Air filter or return air path restricted. iv. Excessive number of outlets closed. 	<p>Check gas rate and burner pressure setting.</p> <p>Adjust fan speed or gas rate accordingly.</p> <p>Check filter is clean and air path is clear.</p> <p>Open additional outlets.</p>

SYSTEME-T models:

d.	Incorrect operation of fan or main burner.	Fault related to SYSTEME-T Control system (refer to pages 18-21)	Consult diagnostic chart and follow recommended procedure.
----	--	--	--

Basic control models:

e.	Pilot alight but main burner not igniting.	i. Mains electrical supply not connected to heater.	Check mains supply.
----	--	---	---------------------

	ii. Controls not demanding heat	Check that time control and room thermostat are operating correctly.
	iii. T3.15A fuse failed.	Replace. If failure occurs again, check wiring for short circuits.
	iv. Loose connection to room thermostat, limit switch, gas control lead, time control, or transformer.	Check connections.
	v. 230V/24V transformer failure.	Check 24V side with test meter, if voltage missing, replace transformer.
	vi. Faulty relay module	Check 230V at white wire from switch S5
	vii. Multifunctional Control faulty.	Replace Multifunctional Control.
	viii. Limit Switch faulty.	Short circuit control and replace if necessary.
	ix. Room thermostat or external wiring faulty.	Fit temporary loop in heater thermostat socket. If heater ignites, external circuit or room thermostat is faulty.
f.	Main burner lights but fan fails to run after approx. 3 min.	
	i. Loose electrical connection at fan control.	Check connections.
	ii. Fan Delay Control faulty.	Replace.
	iii. Faulty fan assembly.	Replace, taking care not to damage impeller.
	iv. Burner pressure setting incorrect.	Adjust pressure as necessary.
g.	Main burner operating with intermittent fan operation.	
	i. Gas rate or burner pressure setting too low.	Check gas rate and burner pressure setting.
	ii. Fan Delay Control faulty	Replace.
h.	Noisy operation.	
	i. Gas pressure too high.	Check burner pressure setting.
	ii. Noisy fan motor.	Replace fan assembly.
	iii. Fan speed setting too high.	Adjust fan speed.
i.	Fan runs for excessive period or operates intermittently after main burner shuts down.	
	i. Fan delay control faulty.	Replace.

9.3 The SYSTEM E-T module is fitted with a diagnostic light emitting diode (LED) which is visible through a hole in the module cover, as shown in Fig. 5 below. If the LED is flashing, this means that :

- 9.3.1 The fan is not connected, or
- 9.3.2 The capacitor is not connected, or
- 9.3.3 There is a short circuit in the fan supply.

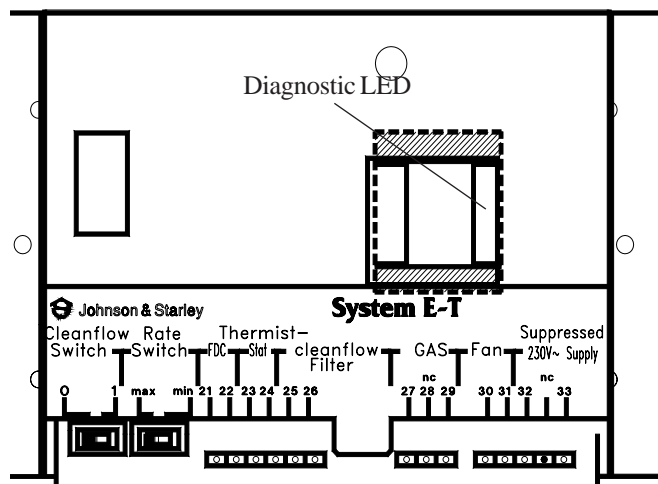
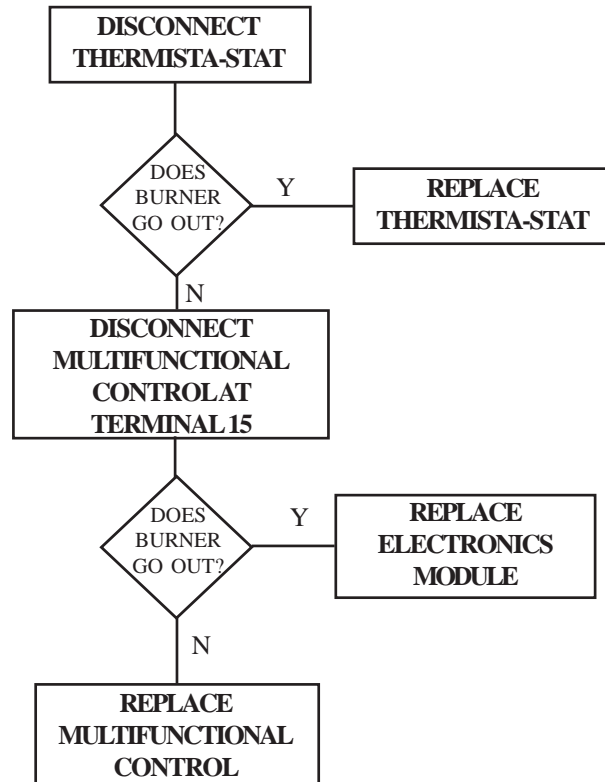

Fig. 6
SYSTEM E-T Electronic Module

SYSTEM E-T DEFECT DIAGNOSTIC FLOW CHART

MAIN BURNER NOT CYCLING (ROOM TEMPERATURE TOO HIGH)



FAN CONTINUES TO RUN, OR CYCLES AFTER HEATING IS TURNED OFF

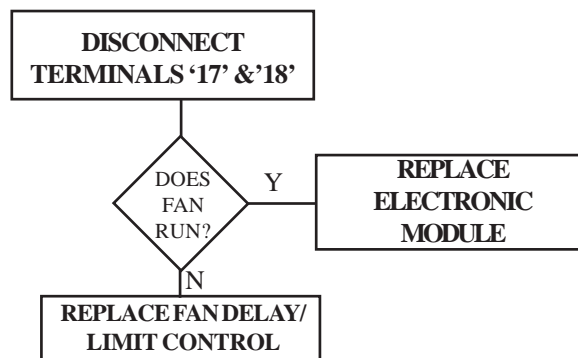

MAIN BURNER NOT OPERATING

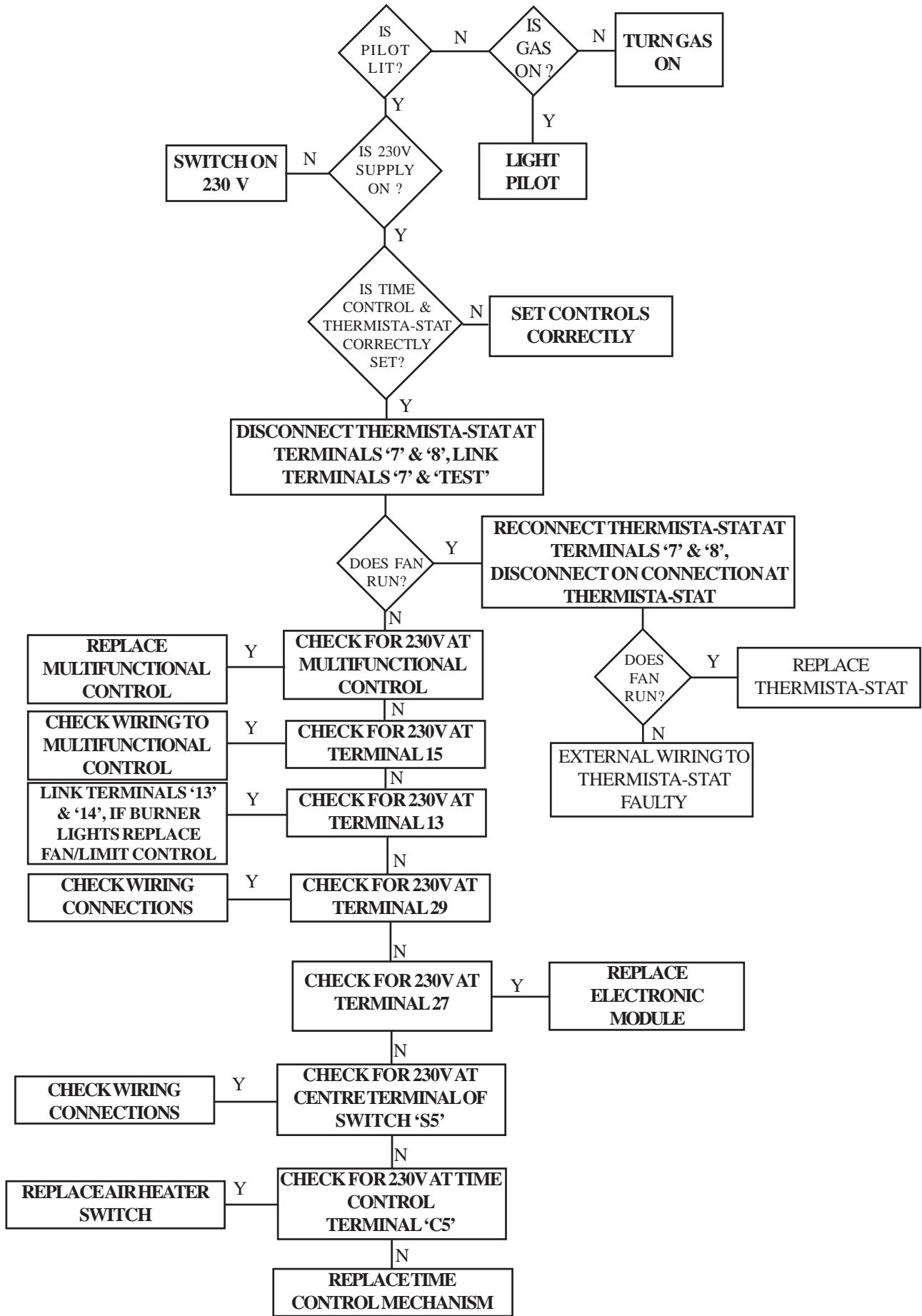

FAN OPERATES BUT BURNER CYCLES BEFORE REQUIRED TEMPERATURE IS REACHED

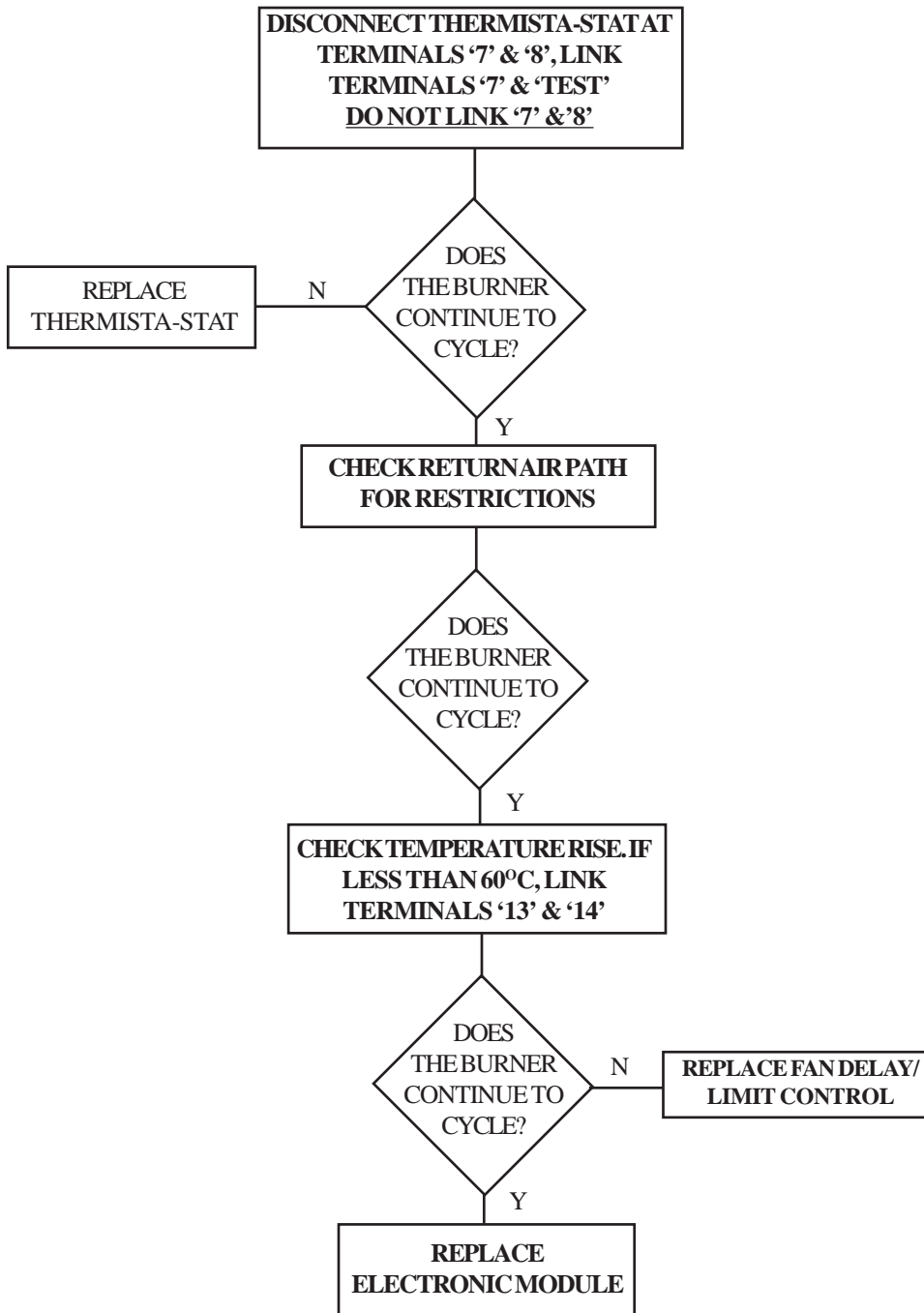

MAIN BURNER ON BUT FAN NOT RUNNING

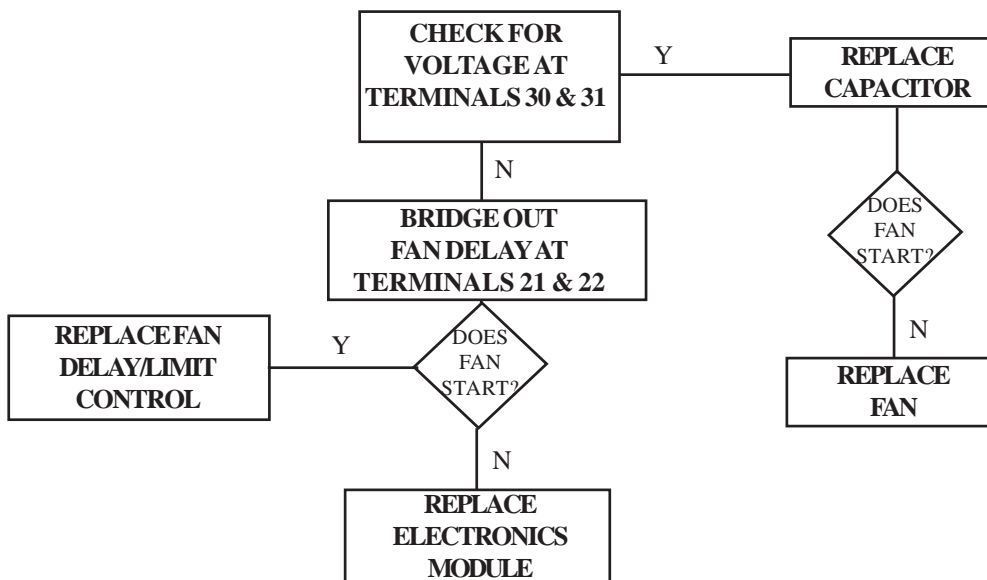

FAN RUNS BUT MAIN BURNER NOT OPERATING

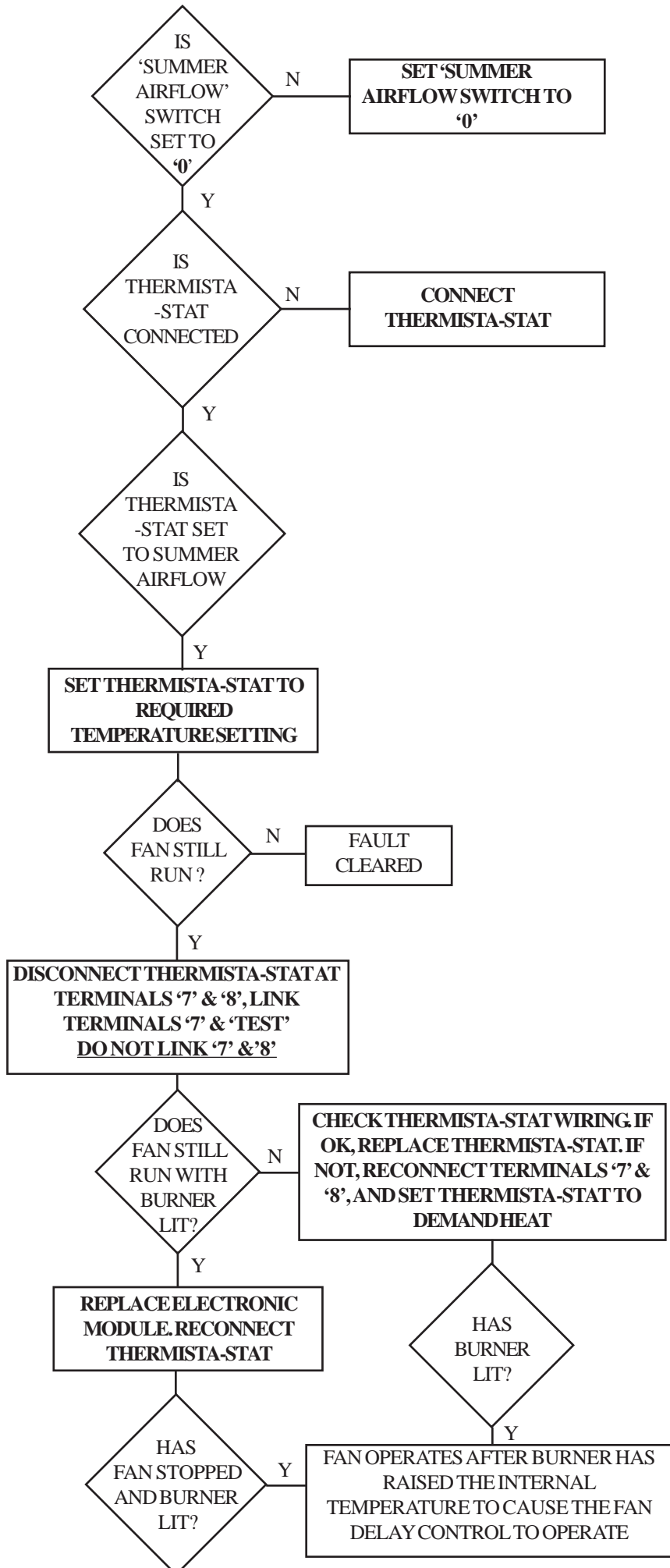

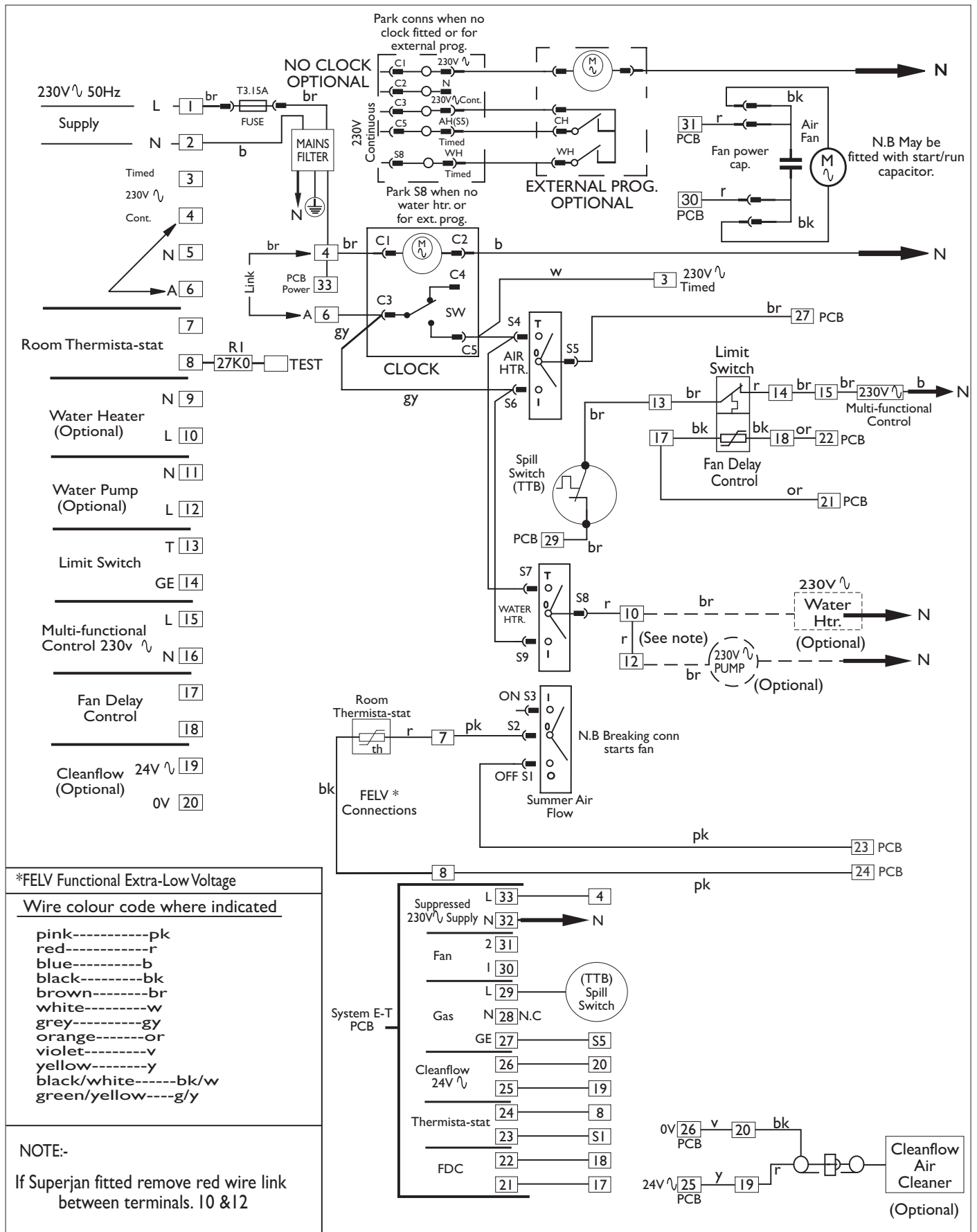

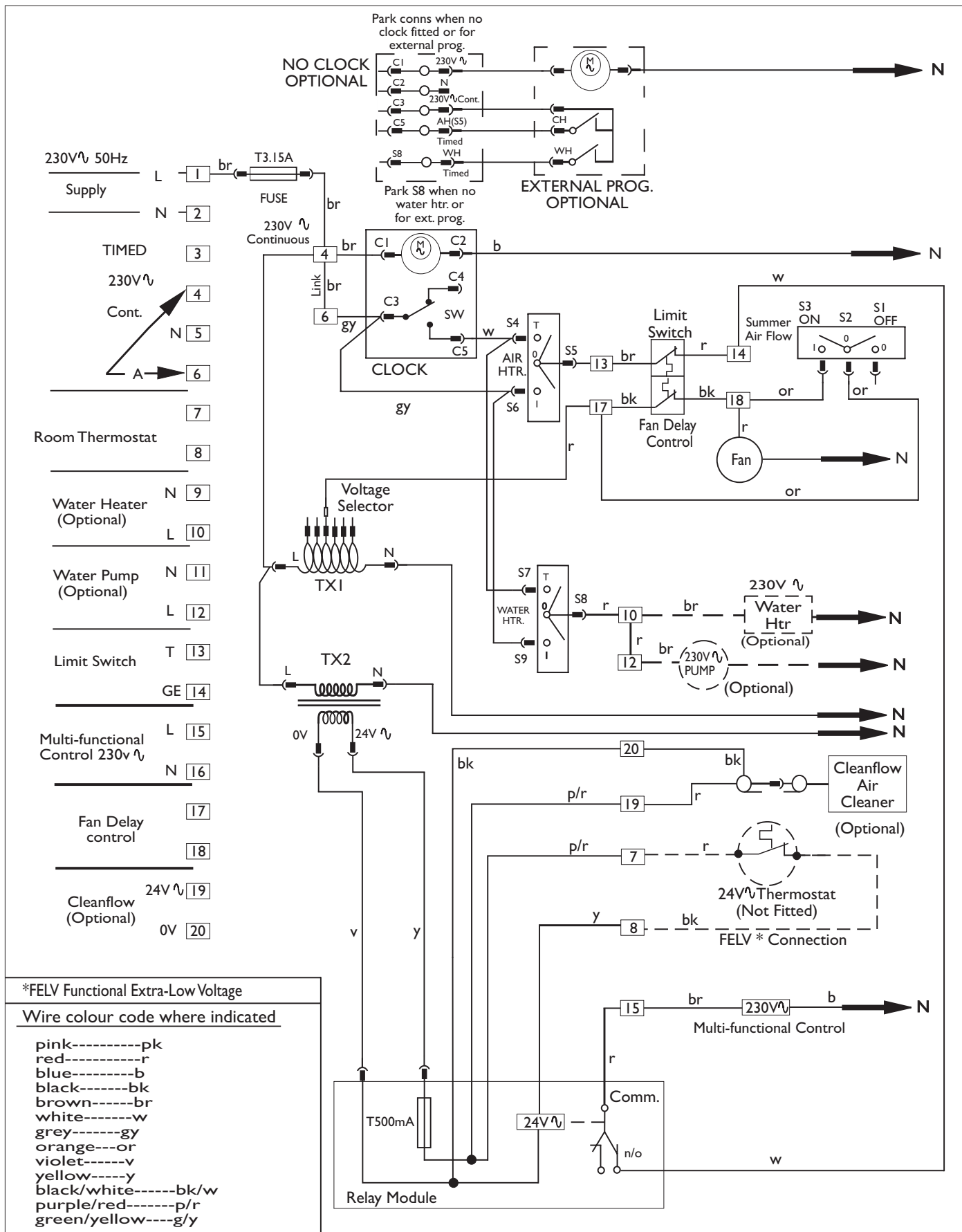

Fig. 7b Basic Control
Functional Diagram

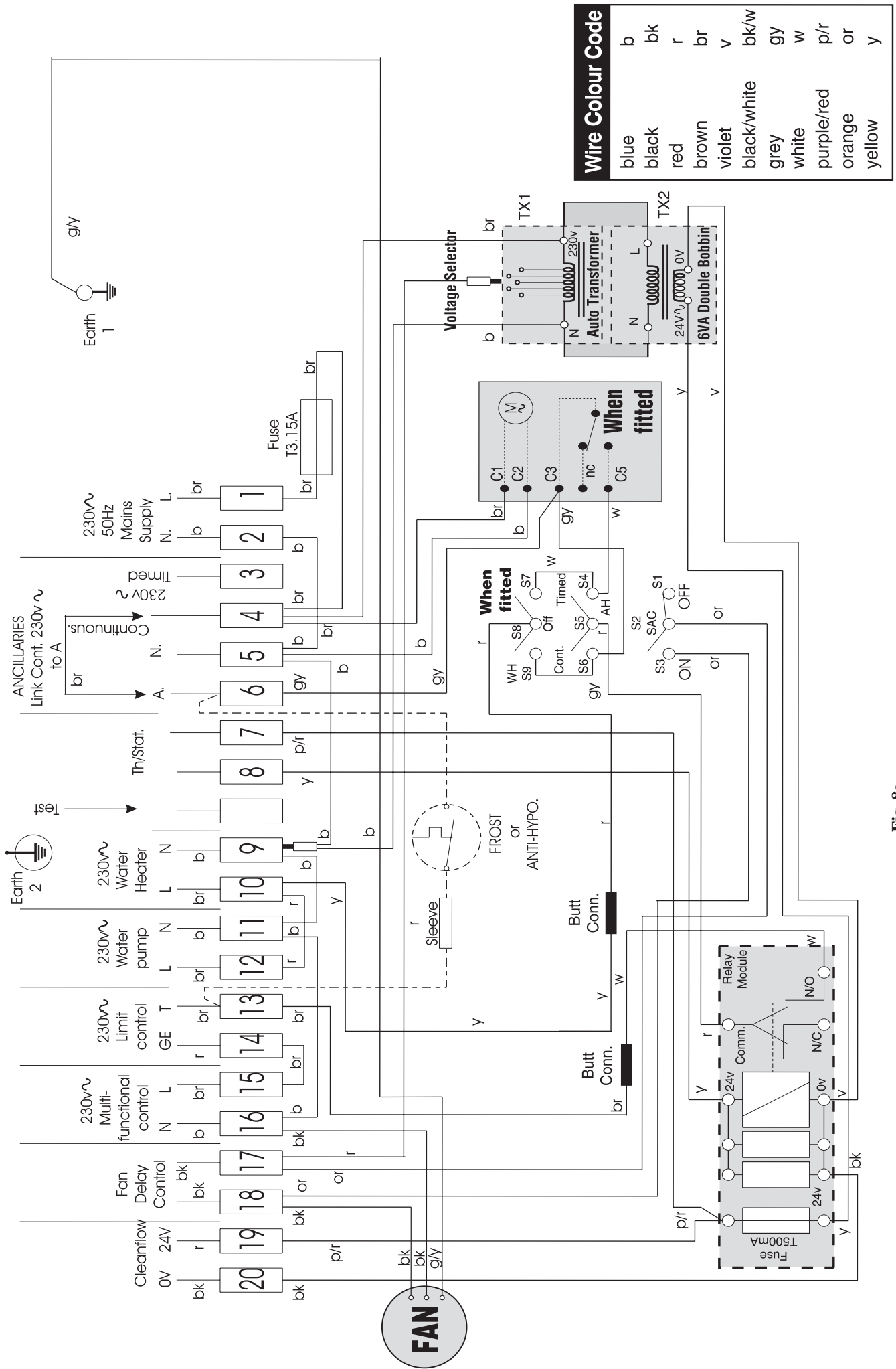
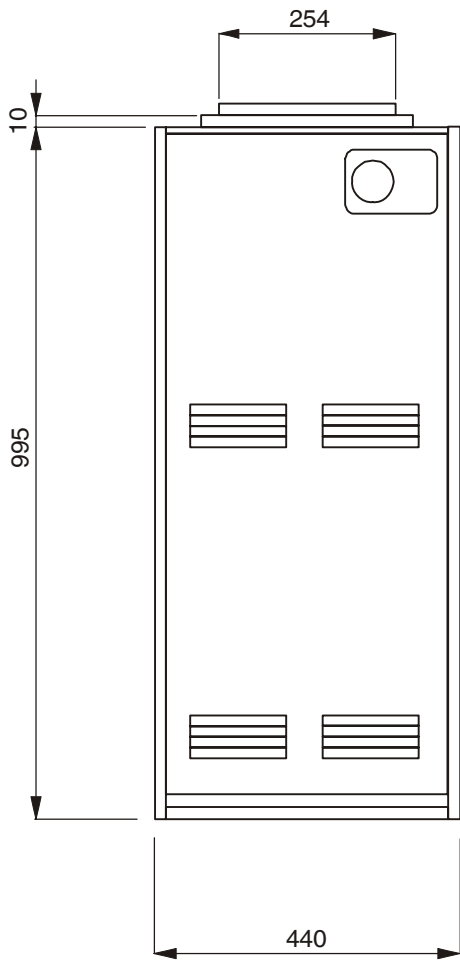
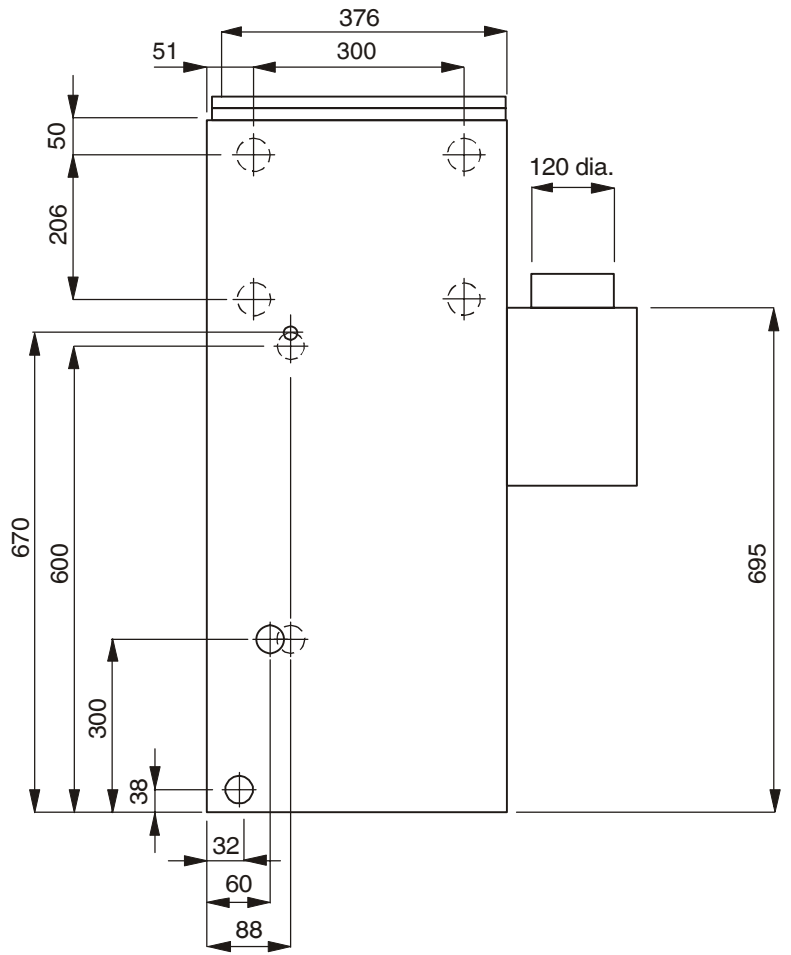

Fig. 8a
System ET Circuit Diagram



FRONT VIEW



SIDE VIEW

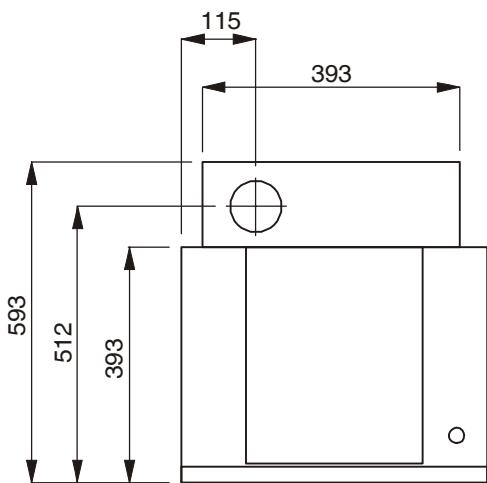

TOP VIEW

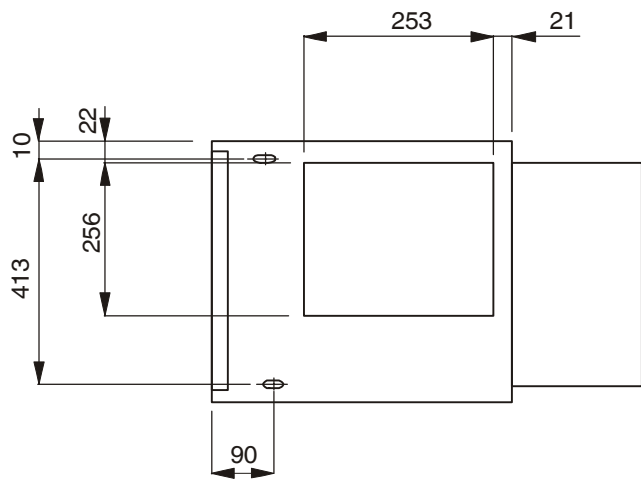

BASE VIEW

Fig. 9
Principal Dimensions

SERVICE RECORD

It is recommended that your heating system is serviced regularly and that the appropriate Service Record is completed.

Service Provider

Before completing the appropriate Service Record below, please ensure you have carried out the service as described in the manufacturer's instructions.

Always use the manufacturer's specified spare part when replacing controls.

SERVICE 1 Date

Energy Efficiency Checklist completed? Yes No

Engineer Name

Company Name

Telephone Number

Gas Safe Register Number

Comments

Signature

SERVICE 2 Date

Energy Efficiency Checklist completed? Yes No

Engineer Name

Company Name

Telephone Number

Gas Safe Register Number

Comments

Signature

SERVICE 3 Date

Energy Efficiency Checklist completed? Yes No

Engineer Name

Company Name

Telephone Number

Gas Safe Register Number

Comments

Signature

SERVICE 4 Date

Energy Efficiency Checklist completed? Yes No

Engineer Name

Company Name

Telephone Number

Gas Safe Register Number

Comments

Signature

SERVICE 5 Date

Energy Efficiency Checklist completed? Yes No

Engineer Name

Company Name

Telephone Number

Gas Safe Register Number

Comments

Signature

SERVICE 6 Date

Energy Efficiency Checklist completed? Yes No

Engineer Name

Company Name

Telephone Number

Gas Safe Register Number

Comments

Signature

SERVICE 7 Date

Energy Efficiency Checklist completed? Yes No

Engineer Name

Company Name

Telephone Number

Gas Safe Register Number

Comments

Signature

SERVICE 8 Date

Energy Efficiency Checklist completed? Yes No

Engineer Name

Company Name

Telephone Number

Gas Safe Register Number

Comments

Signature

SERVICE 9 Date

Energy Efficiency Checklist completed? Yes No

Engineer Name

Company Name

Telephone Number

Gas Safe Register Number

Comments

Signature

SERVICE 10 Date

Energy Efficiency Checklist completed? Yes No

Engineer Name

Company Name

Telephone Number

Gas Safe Register Number

Comments

Signature

SHORT LIST OF SPARES**HI-SPEC J25**

KEY	G.C No	MFR'S No	DESCRIPTION	QTY
1	232 878	BOS 02064	Fan Assembly	1
2	381 627	1000-0701140	Multifunctional Control (S.I.T. Nova)	1
3	379 837	1000-0704250	Pilot Assembly (S.I.T.)	1
4	378 466	BOS 02031	Time Control	1
5	245 503	T193-0751000	Burner Assembly	1
6	398 388	BOS 02060	Main Injector (Bray 33/700)	1
7	395 945	1000-0701160	Piezo Unit (High Energy)	1
8	245 509	1000-0513820	Fuse T3.15A anti-surge	1
9		T193-0145000	Filter Tray	1
10	364 835	S00832	Solenoid Valve	1
11	242 228	S00174	Heat Exchanger	1
12	245 542	1000-0515970	Capacitor 15 uF	1

System E-T Models only

13	245 510	ET001	Electronic Panel Assembly with daughter board	1
14	245 514	1000-0515620	Thermista-stat	1
15	245 515	1000-0515455	Fan Delay/Overheat (limit) switch	1
16		1000-0515090	Mains Filter	1
18		T193 0531000	Complete Electrical panel	1
		T193 0131000	Cabinet Door Assembly	1

Basic Control Models only

19		T193 0530000	Electrical Panel	1
20	245 520	1000-0516125	Fan delay/Overheat (limit) switch	1
21	245 522	1000-0515200	Transformer Fan Speed	1
22	245 525	1000-0515730	Transformer 24 volt	1
23	245 413	1000-0511760	Relay Module	1

Johnson and Starley prides itself on its ability to supply spare parts quickly and efficiently. If you have a problem in obtaining a spare part, please contact Johnson and Starley Spares Department at the address below.

Telephone: (01604) 762881

Fax: (01604) 767408

JOHNSON & STARLEY LTD.
Rhosili Road,
Brackmills,
Northampton NN4 7LZ