

# THE HENRAD USERS GUIDE

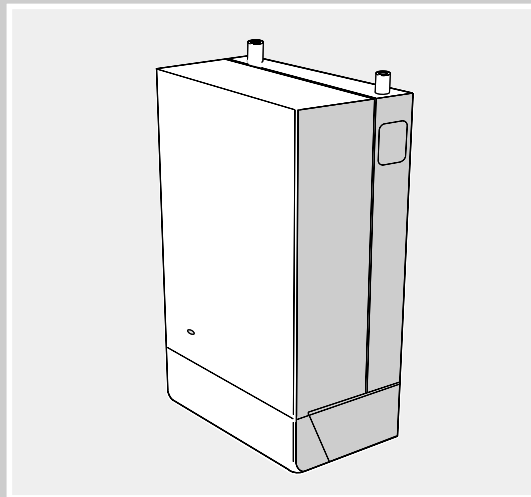

*Henrad*

the wall hung boiler

Wall mounted, fanned,  
balanced flue gas boilers

WH LX 30-80 FF

WH 30-100 FF

**HENRAD**



**Deluxe**

WH LX 30 FF .....	G.C. No. 41 349 94
WH LX 40 FF .....	G.C. No. 41 349 95
WH LX 50 FF .....	G.C. No. 41 349 96
WH LX 60 FF .....	G.C. No. 41 349 97
WH LX 70 FF .....	G.C. No. 41 349 98
WH LX 80 FF .....	G.C. No. 41 349 99

**Standard**

WH 30 FF .....	G.C. No. 41 349 87
WH 40 FF .....	G.C. No. 41 349 88
WH 50 FF .....	G.C. No. 41 349 89
WH 60 FF .....	G.C. No. 41 349 90
WH 70 FF .....	G.C. No. 41 349 91
WH 80 FF .....	G.C. No. 41 349 92
WH 100 FF .....	G.C. No. 41 349 93

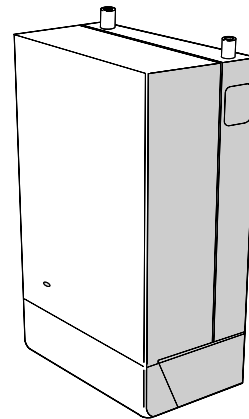
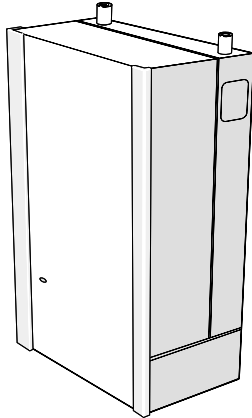

**Introduction**

It is essential that the instructions in this booklet are strictly followed, for safe and economic operation of the boiler.

**Gas Safety (Installation & Use) Regulations 1994, amendments 1996, or the rules in force.**

In your own interest, and that of safety, it is the law that this boiler must be installed by a registered installer, in accordance with all national and local regulations.

**Electricity Supply**

**This appliance must be efficiently earthed.**

Supply: 230 V ~ 50 Hz. The fusing should be 3A.

Connection must be made in a way that allows complete isolation of the electrical supply such as a double pole switch having a 3mm (1/8") contact separation in both poles, or a plug and socket, serving only the boiler and system controls. The means of isolation must be accessible to the user after installation.

**Important notes**

- a. This appliance must not be operated without the casing correctly fitted and forming an adequate seal.
- b. If the boiler is installed in a compartment then the compartment MUST NOT be used for storage purposes.

- c. The ventilation provided for the boiler during installation MUST NOT be blocked, and a check should be made periodically that the ventilation areas are free from any obstruction.
- d. If it is known or suspected that a fault exists on the boiler then it MUST NOT be used until the fault has been corrected by a CORGI registered installer.
- e. Inflammable materials must not be placed in close proximity to the appliance. Materials giving off flammable vapours must not be stored in the same room as the appliance.
- f. Under NO circumstances should any of the sealed components on this appliance be used incorrectly or tampered with.

**Minimum clearances**

A clearance of 533mm (21") MUST be available at the front of the boiler for servicing.

The minimum clearances given below MUST be complied with in order to maintain the safe running of the boiler and to facilitate servicing.

<b>Above the boiler</b>	100 mm	(4")
<b>At each side of the boiler</b>	5 mm	(1/4")
<b>Underneath the boiler</b>	100 mm	(4")
<b>In front of the boiler</b>	450 mm	(17 3/4 ")

**CAUTION. To avoid the possibility of injury during the installation, servicing or cleaning of this appliance care should be taken when handling edges of sheet steel components**

## To light the boiler. Refer to Frame 1

- CHECK THAT THE ELECTRICITY SUPPLY TO THE BOILER IS OFF.
- Deluxe Model (LX)** - Lift the glass fascia and support it with the sliding catch.  
**Standard Model** - Open the controls access door by hinging downwards.
- Ensure that the gas inlet cock (B) is OPEN.
- Press the overheat reset button (D), located as shown in Frame 1.
- Ensure that the mains on/off switch (E) is in the OFF position.
- Switch ON the electricity supply to the boiler. Check that all external controls, e.g. room thermostat etc., are ON.
- Turn the boiler thermostat knob (C) to position 6 and the mains on/off switch (E) to ON. After about 15 seconds the boiler will light automatically - this can be viewed through the sight glass (A). Set the boiler thermostat to the desired position.
- Deluxe Model (LX)** - Lower the glass fascia after pushing in the sliding catch.  
**Standard Model** - Close the controls access door.

In **winter conditions**, i.e. central heating and domestic hot water, the thermostat should be set at position 5 or 6.

For **summer conditions**, i.e. domestic hot water only, the thermostat should be set at position 3.

These settings, however, are offered for general guidance only and other settings may be found preferable, dependent upon the type of system installed or as recommended by the installer.

Approximate flow temperatures for the boiler thermostat settings are:

Knob Setting	Flow Temperature	
	°C	°F
1	56	133
2	61	142
3	66	152
4	72	161
5	77	170
6	82	180

### 1 BOILER CONTROLS

Deluxe Model (LX)

Standard Model

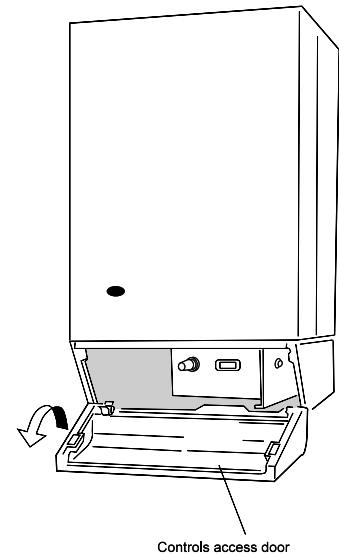
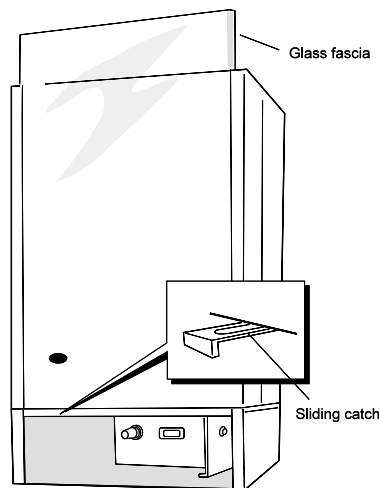

View inside boiler controls area

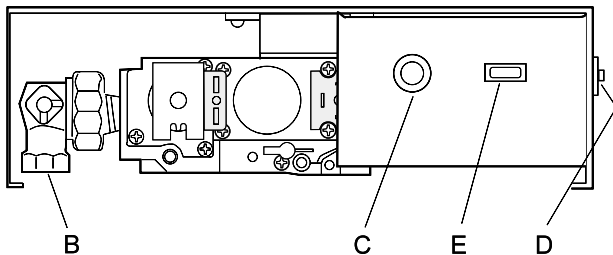

#### LEGEND

- A Sightglass
- B Gas inlet cock (shown in the OPEN position)
- C Thermostat knob
- D Overheat thermostat reset button
- E Mains on/off switch

THE LOG BOOK SHOULD BE COMPLETED AFTER EACH SERVICE AND KEPT WITH THESE INSTRUCTIONS



## ***To shut down the boiler***

### **1. For short periods**

Turn the boiler on/off switch (E) to OFF.  
When heating is again required, restore the switch to ON.

### **2. For longer periods**

Turn the boiler ON/OFF switch (E) to OFF.  
Switch the electricity supply to OFF.

## ***Frost protection***

If no frost protection is provided and frost is likely during a short absence from home, leave the heating controls at a reduced temperature setting.

For longer periods, the entire system should be drained - including the domestic water supply. If the system includes a frost thermostat then, during cold weather, the boiler should be turned OFF at the time switch(es) ONLY. The mains supply should be left switched ON, with the boiler thermostat left in the normal running position.

## ***Boiler Overheat Thermostat***

**(Fitted for sealed systems only)**

The boiler is fitted with a safety 'cutout' thermostat. This will shut down the boiler in the event of overheating. Should this occur allow the boiler to cool, press the reset button (D) then relight as detailed in steps 1-8 in 'To light the boiler'.

*If the cutout condition still persists turn off the boiler and consult a CORGI registered installer.*

## ***Control of water temperature***

1. Adjust the boiler thermostat (C) to give the required temperature for central heating.
2. The boiler thermostat automatically switches the main burner OFF and ON to maintain the selected temperature.

## ***To relight the boiler***

Repeat the procedure 1 - 8, detailed in 'To light the boiler'.

## ***Escape of gas***

Should a gas leak be suspected, contact your local gas supplier without delay.

***Do NOT search for gas leaks with a naked flame.***

## ***Cleaning***

For normal cleaning simply dust with a dry cloth.  
To remove stubborn marks and stains, wipe with a damp cloth and finish off with a dry cloth.

**Do NOT use abrasive cleaning materials.**

## ***Maintenance***

The appliance should be serviced at least once a year by a CORGI registered installer.



**The code of practice for the installation, commissioning & servicing of central heating systems**

Caradon Plumbing Limited is a member of the Benchmark initiative and fully supports the aims of the programme. Benchmark has been introduced to improve the standards of installation and commissioning of central heating systems in the UK and to encourage the regular servicing of all central heating systems to ensure safety and efficiency.



**THIS SYMBOL IS YOUR ASSURANCE OF QUALITY**

These appliances are designed for use with Natural Gas only. They have been tested and conform with the provisions of BS. 6332 and BS. 5258.



LXFF.87/AQ/220  
LXRS.87/AQ/221  
FF.87/AP/107  
RS.87/AP/108

Natural Gas appliances are service listed by British Gas



**CERTIFIED PRODUCT**  
Manufactured under a BS EN ISO 9001:1994 Quality System accepted by BSI.

**Caradon Plumbing Limited** pursues a policy of continuing improvement in the design and performance of its products. The right is therefore reserved to vary specification without notice.

December 1999 UIN 153 957 A02

**Caradon Plumbing Limited**, P.O. Box 103, National Ave, Kingston upon Hull, HU5 4JN. Telephone: 01482 492 251 Fax: 01482 448 858. Registration No. London 322 137. Registered Office: National Avenue, Kingston upon Hull, HU5 4JN. *A subsidiary of Caradon plc.*

# HENRAD

**Henrad Consumer Helpline: 01482 498660**

## YOUR FEEDBACK

*and your chance to win a free boiler*

At Henrad we've been leaders in the design and engineering of robust and reliable boilers for over 90 years. We want to continue as leaders by listening to your suggestions for how to improve our boilers and our service. We will be giving away a free boiler for the five best ideas every year (to be selected by our Technical Director). Please complete this form, using extra sheets if required, and post it or fax it to us on 01482 498699.

### *Boiler details*

Model / Size (details on control panel door)

Date of Installation

### *Installer details*

Name

Address

Post Code

Telephone (*Please include STD*

**Caradon**   
**Plumbing Solutions**

*Henrad Consumer Helpline: 01482 498660*

## Further information

If you would like information about Henrad Boilers please complete this sheet and fax it to us on 01482 498699 or post it to Caradon Plumbing Limited, PO Box 103, National Avenue, Kingston upon Hull, HU5 4JN.

### Installer details

Name

Address

Post Code

Telephone (Please include STD

### General information required

- Please send me details of Henrad Training Courses.
- Please arrange for a technical representative to contact me.
- Please arrange for me to join an Henrad factory tour.

### Domestic boiler required

- The Henrad Guide: a specifier's and installer's introduction to the Henrad domestic boiler range.
- The Henrad Householders Guide: to assist the installer when presenting to his/her customers.

### Technical information required

- The Henrad C FF combi boilers
- The Henrad WH FF wall hung boiler
- The Henrad WHLX FF deluxe wall hung boiler
- The Henrad FS FF floor standing boiler
- The Henrad SE FF heat-saving boiler
- The Henrad CC FF combi boiler
- The Henrad SEC FF super efficiency combi boiler

**Caradon**   
**Plumbing Solutions**

Caradon Plumbing Ltd., PO Box 103, National Avenue, Kingston upon Hull, HU5 4JN. Telephone: 01482 492251 Fax: 01482 448858.

**Henrad Consumer Helpline: 01482 498660**

UIN. 153 957 A0

