

GENERAL INFORMATION

BATTERY

The programmer is fitted with a non-rechargeable, non-serviceable long life battery, which will maintain the programmed time settings with the mains supply disconnected. THIS RESERVE SHOULD BE SUFFICIENT TO COVER POWER INTERRUPTIONS DURING THE LIFE OF THE UNIT. During power interruptions the display will be blank.

SERVICE AND REPAIR

This programmer is NOT user serviceable. Please do not dismantle the unit. In the event of a fault developing please refer to the RESET THE PROGRAMMER section below. If this fails to resolve the problem please contact a local heating engineer or a qualified electrician.

RESETTING THE CHANNELPLUS H47XL SERIES 2

Electronic equipment can in some circumstances be affected by electrical interference. If the display becomes frozen or scrambled; or if you wish to revert back to the default settings please use the following procedure.

RESET PROCEDURE

PLEASE NOTE; Using this procedure will restore the ChannelPlus to the original factory programme settings, the time setting will remain correct.

Lower the front flap of the unit. On the far right (forth) Channel press the ADVANCE(Enter) and SELECT(Blue) buttons together then release the buttons and the programmer will return to the preset factory settings.

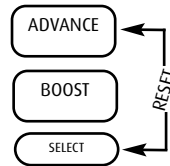

SPECIFICATION H47XL SERIES 2

Contact type: Micro dis-connection(Voltage free)

Contact rating: 3(1)Amps 230-240V AC

Power supply: 230V AC 50Hz

Operating Temperature range: 0°C to 40°C

Double insulated.

Dirt protection: Normal situations.

Enclosure protection: IP30

Purpose of control: Electronic time switch

Independently mounted control for surface mounting.

Operating time limitation: Continuous

Battery Type: Lithium

Case material: Thermoplastic, flame retardant

Dimensions: 163mm x 101mm x 37mm

Display: Fully graphical LCD, back-lit

Clock: 24hour /12 hour AM/PM

Display time adjustment: 1 Minute steps

Switched time adjustment: 10 Minute steps

Programme selection: Auto, On all day, On constant, Off, Holiday

Operating periods per day: Three for Heating 1, Heating 2 and Water (separate daily programme for each Channel)

Override: Boost, 1 or 2 Hours
Extension to ON period, 1 Hour or 2 Hour
Instant Advance

Backplate: 9 Pin terminal connection

Horstmann Controls Limited

Bristol

BS4 1UP

t:0117 9788 773 - f:0117 9788 701

Email: sales@horstmann.co.uk
Website: www.horstmann.co.uk



LEAFLET No P82733
ISSUE 1

CHANNELPLUS H47XL SERIES 2
INSTALLATION INSTRUCTIONS



HORSTMANN

Horstmann ChannelPlus H47XL Series 2 - Four Channel Central Heating and Hot Water Programmer.

The H47XL programmer offers the equivalent of four independent seven day timers in one modern, good looking enclosure.

Each of the four channels offers up to three programmed operating periods per day for each of the seven days of the week, with a boost and advance available on each.

The fully graphical back-lit display combined with menu driven programming is designed to simplify the day-to-day operation of the H47XL

INSTALLATION AND CONNECTION SHOULD ONLY BE CARRIED OUT BY A SUITABLY QUALIFIED PERSON AND IN ACCORDANCE WITH THE CURRENT EDITION OF THE IEE WIRING REGULATIONS.

WARNING : ISOLATE MAINS SUPPLY BEFORE COMMENCING INSTALLATION

FITTING THE BACKPLATE

Once the Backplate has been removed from the packaging please ensure the programmer is re-sealed to prevent damage from dust, debris etc.

The Backplate should be fitted with the wiring terminals located at the top and in a position which allows the relevant clearances around the programmer. (See diagram)

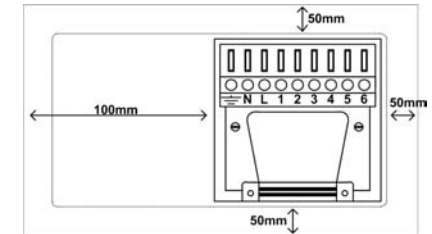

DIRECT WALL MOUNTING

Offer the plate to the wall in the position where the programmer is to be mounted, remembering that the Backplate fits to the right hand end of the programmer.

Mark the fixing positions through the slots in the Backplate (Fixing centres 60.3mm), drill and plug the wall, then secure the plate in position. The slots in the Backplate will compensate for any misalignment of the fixings.

WIRING BOX MOUNTING

The Backplate may be fitted directly on to a single gang steel flush wiring box complying with BS4662, using two M3.5 screws.

ChannelPlus series 2 programmers are suitable for mounting on a flat surface only, they must not be positioned on a surface mounted wall box or on unearthed metal surfaces.

ELECTRICAL CONNECTIONS

All necessary electrical connections should now be made. Flush wiring can enter from the rear through the aperture in the Backplate. Surface wiring can only enter from beneath the programmer and must be securely clamped.

The mains supply terminals are intended to be connected to the supply by means of fixed wiring.

The recommended cable sizes are 1.0mm² or 1.5mm².

ELECTRICAL CONNECTIONS

ChannelPlus programmers are double insulated and do not require an Earth connection but an Earth terminal is provided on the Backplate for terminating any cable Earth conductors. Earth continuity must be maintained and all bare Earth conductors must be sleeved. Ensure that no conductors are left protruding outside the central space enclosed by the Backplate. When used to

control MAINS VOLTAGE SYSTEMS Terminals L,2 and 5 should be electrically linked by means of a suitable piece of sleeved conductor. When used to control EXTRA LOW VOLTAGE SYSTEMS these links MUST NOT be fitted. An example circuit diagram is shown below. This diagram is schematic and should be used as a guide only. **Please ensure that all installations comply with the current IEE regulations.**

INTERNAL WIRING DIAGRAM H47XL Series 2

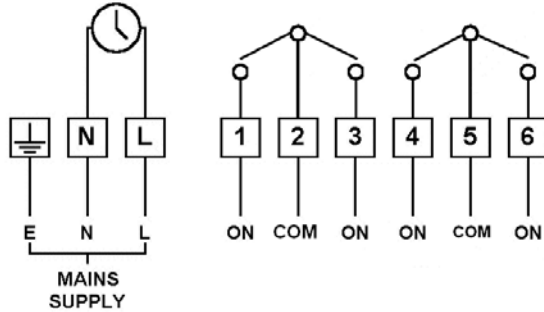

NEW INSTALLATIONS

Please ensure that all installations comply with the current IEE regulations.

For reasons of space and clarity the diagram has been simplified, for instance some Earth connections have been omitted. Other control components shown in the diagram i.e. Valves, RoomStats etc. are general representations only. However the wiring detail can be applied to the corresponding models of most manufacturers e.g. Horstmann, Honeywell, Danfoss Randall etc.

Cylinder and Room Thermostat Key:

C = Common CALL = Call for heat or break on rise SAT = Satisfied on rise N = Neutral

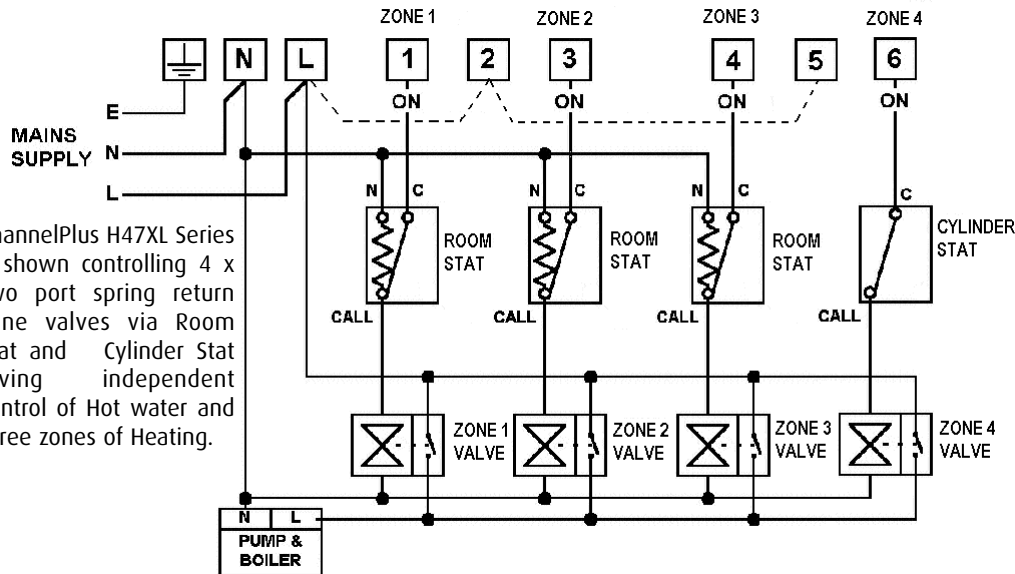

ChannelPlus H47XL Series 2 shown controlling 4 x two port spring return zone valves via Room Stat and Cylinder Stat giving independent control of Hot water and three zones of Heating.

NOTE: If the ChannelPlus H47XL Series 2 is being installed on an existing system additional equipment such as extra zone valves will have to be fitted in order to achieve full four channel control.

COMMISSIONING THE PROGRAMMER

Ensure all dust and debris has been cleared away from the work area before removing the programmer from its packaging.

All ChannelPlus XL controls are fitted with a battery reserve which maintains programmed times in the event of a mains power failure.

REAR VIEW OF CHANNELPLUS XL PROGRAMMER

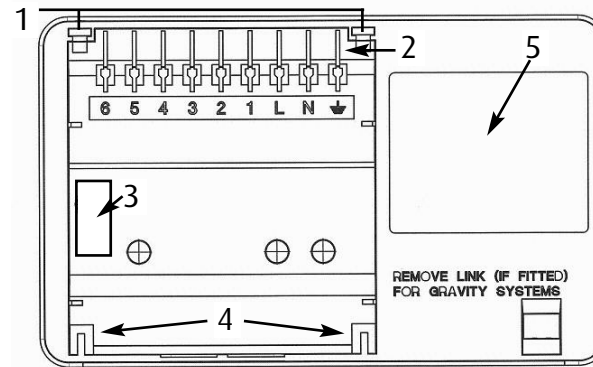

- 1 - RETAINING SCREWS
- 2 - CONNECTOR BLADES
- 3 - PRODUCTION DATE LABEL
- 4 - POSITIONING LUGS
- 5 - RATINGS LABEL

FITTING THE PROGRAMMER

If surface wiring has been used, remove the knockout/insert from the bottom of the programmer to accommodate it. Loosen the two 'captive' retaining screws on the top of the unit. Now fit the programmer to the Backplate, line the lugs on the programmer with the flanges on the Backplate.

Swing the top of the programmer into position ensuring that the connection blades on the back of the unit locate into the terminal slots in the backplate.

Tighten the two 'captive' retaining screws to fix the unit securely, then switch on the mains supply.

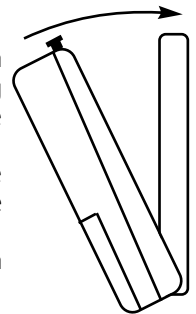

END VIEW OF CHANNELPLUS PROGRAMMER

INITIAL SET-UP

Once the mains power has been switched on the ChannelPlus H47XL Series 2's display will illuminate. The programmer has a number of pre-programmed functions to assist the initial set-up, which are detailed below;

TIME AND DATE - The programmer has been pre-set with the current time and date during manufacture. No alteration should be required to the time and date, however if any modification is required please refer to the 'Adjusting Time and Date' section of the user guide.

PROGRAMME TIMES - The programmer has been pre-set with default heating and hot water times, these can be altered to meet the user requirements, please refer to the 'Setting the Programme Times' section of the user guide.

PLEASE ENSURE THAT THE USER GUIDE IS HANDED OVER TO THE END USER.