

Prestige

47 - 64 - 85

*Installation, Operating and
Servicing Instructions*



excellence in hot water

INDEX

INTRODUCTION

Intended users of these instructions
Symbols
Applicable standards
Warnings

FUNCTIONING

General
Functioning of domestic hot water
Functioning of central heating

INSTALLATION

Mounting boiler
Circuit connections
Gas connection
Air + fluedas ducts
Frost protection
Setting Gas-Air ratio control
Electrotechnical connection
Put into operation
Put out of operation

USER GUIDE

Using the boiler
Control Settings

MAINTENANCE

DESCRIPTION

DIMENSIONS

ELECTRICAL WIRING

Electrical wiring prestige 47/64
Electrical wiring prestige 85

BOILER FEATURES

SERVICE RECORD

Installation record

INTRODUCTION

INTENDED USERS OF THESE INSTRUCTIONS

These instructions are intended for
- specifying engineers
- installing engineers
- users
- servicing technicians

SYMBOLS

The following symbols are used in these instructions:



Essential instruction for operating the system correctly.



Essential instruction for personal safety and environmental protection.

APPLICABLE STANDARDS

The products have received the "EC" certificate in accordance with the standards prevailing in different countries (European Directives 92/42/EEC, "efficiency", 90/396/EEC "gas appliances"). These products have also received the Belgian "HR+" (gas boilers) marks.



WARNINGS

These instructions are an integral part of the equipment to which they refer and must be supplied to the user.

The product must be installed and serviced by qualified engineers, in compliance with the prevailing standards.

ACV accepts no liability for any damage resulting from incorrect installation or from the use of components or fittings not specified by ACV.



Failure to observe instructions regarding tests and test procedures can result in personal injury or pollution risks.

Note:

ACV reserves the right to modify the technical specifications and components of its products without prior notice.

GENERAL

The PRESTIGE boiler is a room-sealed boiler. The boiler has an aluminum heat exchanger, which is mounted in the room-sealed jacket.

When there is heat-request, the electronic control will activate the pump, fan and the burner.

The combustion air will be aspirated by the fan through the air-supply ducts from outside. The air is sucked into a venturi, which creates a vacuum.

This vacuum is a size for the amount of air, which is being aspirated, and this signal is transmitted through an internal channel to the gas valve.

The gas valve will then automatically supply the exact amount of gas, which is injected into the venturi and mixed with the air. This mixture is supplied to the burner. Ignition and ionization-control is done by means of an electrode, which is mounted underneath the burner.

Temperature- and safety-control is performed by means of NTC's. The information of these sensors is processed by the electronic control, which also secures general functioning and safety of the boiler.

FUNCTIONING OF DOMESTIC HOT WATER**With separate hot water tank**

Heat-request for DHW has always priority above CH.

In case a hot water tank with a thermostat is connected to the boiler, heat-request for DHW is generated by the switch of this thermostat. This thermostat then also determines the hysteresis. If the duration of the heat-request is long enough, the flow-temperature will arrive at the set-value. If the flow-temperature exceeds this set-value, the boiler will switch off.

In case a hot water tank with a NTC is connected to the boiler, The NTC will control the heat-request for DHW, which is settable between 10 to 60 °C.

FUNCTIONING OF CENTRAL HEATING**Room thermostat**

On heat-request of the room-thermostat (and absence of DHW-request), the 3-way-valve will be activated immediately. During the change of the position of the 3-way-valve (15 seconds) the pump is not activated. After this the pump is activated and the control will set the modulating burner to arrive at the flow-temperature setting.

This flow-set-value can be adjusted; the standard setting is 75 °C. In case an out-door sensor has been connected, the flow-set-value is automatically adjusted according to the heating curve which is standard foreseen in the electronic control.

Out-door sensor

The boiler can also be controlled by means of an out-door sensor. This sensor with installation prescription can be ordered separately. This control is easy to use and can be programmed for all heating situations. For more information take contact with our local distributor.

MOUNTING BOILER

The boiler should be installed in accordance with all the local and regional regulations.

1. The boiler has to be installed in an appropriate place. Make sure this place is free of any risk of frost.
2. Mount the bracket horizontally to a flat surface. Maintain at least 10 cm space to the left and right side of the boiler to enable maintenance of the boiler.
3. Hang the boiler onto the bracket on the wall.
4. Remove the protective caps from the tubes. Be careful! It is possible that dirty water comes out of the tubes.
5. Fill the siphon with fresh water.

CIRCUIT CONNECTIONS

1. The pump is integrated in the appliance and has a switch with 3 positions to adjust the performance of the pump. Set this switch to the need of the installation.
2. Mount the separate automatic purge on top of the boiler.
3. Flush the entire installation thoroughly with fresh water.
4. Mount a fill and drain tap on a suitable position in the installation.
5. Fill the installation with clean, fresh water. The pH must be between 4 and 8,5. It is not allowed to add any chemicals (e.g. anti-freeze) to this water.
6. The connections for central heating are 5/4" conical thread.
7. The connection for gas is 3/4" conics thread.
8. A pressure relief valve and an expansion vessel have to be foreseen in the installation, near the boiler. Make sure the expansion vessel has enough capacity for the installation.
9. Discharge the condensate via a funnel and a siphon to the sewer.
10. In case an extra pump is mounted in the installation, make sure this additional pump does not cause any pressure difference over the boiler.
11. A purge device has to be foreseen at the highest point in the installation.
12. Mount the exhaust pipes in such a way that any condensate built in these tubes will drain towards the boiler.

GAS CONNECTION

1. The gas connection must be the actual regulations.
2. Check the gas pipe for any dirt, in order to prevent malfunctioning of gas controls of the boiler.
3. Maximum pressure for the gas valve is 50 mbar.
4. Check the load of the boiler.

AIR + FLUEGAS DUCTS**Exhaust Connection**

Application possibilities

The possible applications are drawn in figure...

The boiler is approved for categories B23 B33 C13x C33x C43x C53x C63x C83x

It is possible to combine the air supply and flue gas exhaust with other appliances. The design of such a combination has to be approved in advance by the local gas authorities (so before actually mounting the boiler)

Mount the exhaust pipes in such a way that any condensate built in these tubes will drain towards the boiler.

Calculation of maximum flue length;

Maximum allowable total air and flue pipe resistance is 1,4 mbar. It is not allowed to connect air-supply + exhaust ducts with higher resistance. The maximum length in meters for parallel and concentric systems is given in the table below.

	Ø 80 / Ø 80	Ø 100 / Ø 100	Ø 80 / Ø 125	Ø 100 / Ø 150
Prestige 47	13	47	17	34
Prestige 64	9	33	12	24
Prestige 85	-	-	-	25



Note:

- A 90 ° bend is considered to have the same resistance as 1 m straight tube.
- The air-supply and exhaust system has to fulfill the local and national regulations.

FROST PROTECTION

The boiler is protected against frost. During long absence in the winter the installation must be protected from freezing by partially opening all convector valves. In this case the room thermostat is not to be setted at a temperature under 15 °C.

When the flow sensor diminishes to 7 °C, the pump will be activated. If the flow temperature decreases further, the boiler will light when the flow sensor detects a temperature of 3 °C. The burner will remain on until the flow temperature has risen to 10 °C. After this the pump will run for another 15 minutes.



WARNING:

This is only an automatic protection of the boiler. This does not prevent the installation from freezing. Convectors, which are likely to freeze, can be equipped with a frost thermostat, which is to be connected parallel to the room thermostat.

SETTING GAS-AIR RATIO CONTROL

The boiler is equipped with a gas-air-ratio control. This means that the amount of gas is automatically controlled depending on the amount of air. The advantage is that the %CO₂ is more or less constant over the whole modulation level of the boiler. The %CO₂ is, depending of the type of gas, setted according the table below:

Type of gas	supply pressure	% CO ₂ (max. load)	% CO ₂ (min. load)
E-group / G20	20 mbar	9,0 ± 0,2	8,7 ± 0,2
LL-group / G25	20 mbar	9,0 ± 0,2	8,7 ± 0,2
LPG / G30	50 mbar	11,6 ± 0,2	11,3 ± 0,2
LPG / G31	50 mbar	10,6 ± 0,2	10,3 ± 0,2

The manufacturer has setted the boiler for - E-group / G20. This is indicated by means of a sticker, which is mounted below the type-plate.

Checking of the %CO₂ has to be done both on max load and min load:

- Open the appliance by removing the front cover
- Light the boiler in max load by means of the servicemode H (mode and + button)
- Wait for equilibrium
- Now the CO₂ has to be 8,9 ± 0,2 %
- In case the %CO₂ is not correct, you can adjust it by turning the brass screw near the venturi (clockwise = lower CO₂, counter clockwise = higher CO₂)
- Set the boiler to the min load by means of the servicemode L (mode and - button)
- Wait for equilibrium
- Now the CO₂ has to be 8,7 ± 0,2 %
- In case the %CO₂ is not correct, you can adjust it by turning the white plastic screw on the gas valve (clockwise = higher CO₂, counter clockwise = lower CO₂)

In case the installation is supplied with a different type of gas, the boiler has to be re-adjusted by the installer according the procedure mentioned above.



NOTE:

- For setting to LL-group, the brass screw near the venturi has to be turned a few times counter clockwise.
- For setting to LPG, the brass screw near the venturi has to be turned a few times clockwise.



IMPORTANT:

Subsequently the enclosed sticker "setted for LL group" or "setted for LPG" has to be put over the original sticker "setted for E-group"!!!

ELECTROTECHNICAL CONNECTION

1. The electrical installation has to meet the actual regulations
2. The wall socket has to be mounted in an easy accessible position near the boiler.
3. It is not allowed to modify the internal wiring of the boiler.
4. The appliance is equipped with an earthed plug.
5. The connection of the room thermostat is in the control box. This contact is standard foreseen with a bridge. To replace this bridge by the wires of the room thermostat, hinge the lower front cover down. Unscrew the display cover and open the control box by hinging the display cover down as well. The room thermostat has to be connected at the pos 12 + 14 of the screw terminals. The maximum cross section of the wires is 0,75 mm². The contact of the room thermostat has to be potentialfree.
6. To connect timers which need 24 V supply from the boiler, there is 2,4 VA available on the pos 11 and 13 of the screw terminals.
7. To connect a sanitary thermostat, sanitary NTC, 3-wayvalve or sanitary pump, there are screw terminals available.

Out-door temperature control

The out-door sensor has to be mounted to the northern wall of the house at a height of approximately 2 m.

The boiler is standard set to operate with a room thermostat. The MCBA will automatically detect when an out-door sensor is connected. The control will automatically be adapted to operate with room-thermostat + out-door sensor.

Personal computer connection

For service and maintenance purposes it is possible to connect a personal computer to the control of the boiler.

Please contact the manufacturer to receive more information about this.

Separate hot water tank

In case a separate hot water tank is connected to the boiler, you must use an electrical 3-way-valve 24 V (Honeywell VC 8010, "2 wire + common), a spring assisted 3-way-valve or an external sanitary pump.
The wiring has to be done according the diagram in figure

If using a sanitary thermostat or sanitary NTC, it has to be connected to pos 20 + 21 of the screw terminals.
The standard flow temperature for loading the hot water tank is 80 °C.

PUT INTO OPERATION

1. Fill and purge the installation. The water pressure in the boiler has to be between 1,5 and 2 bars. The boiler (*not the installation*) is purged by the automatic purge, which is mounted on top of the boiler.
2. Check all gas and water connections for leakages. Purge the gas tube.
3. Check if the type of gas and the nominal supply pressure, as mentioned on the sticker below the typeplate, are present.
4. Connect the plug in the wall-socket. Turn on the main switch on the boiler. After a few moments the boiler will automatically ignite.
5. Set the room thermostat to the highest value and heat up the installation. After this set the room thermostat to the lowest value.
6. Purge the installation again and refill if necessary.

PUT OUT OF OPERATION

By pushing the - button for 3 seconds, the boiler is off. The display will show: OFF.
The anti-frost protection is still enabled.



To put the boiler back to normal operation again, push the - button for 3 seconds again.

USING THE BOILER



**Your system should be serviced at least once a year by a qualified engineer.
If the boiler is subject to heavy use, it may require servicing more than once a year - consult your service engineer for advice.**

**Starting the burner:
In normal operation, the burner starts automatically whenever the boiler temperature falls below the set temperature.**

After the mains is connected, or after a reset, the 3-way valve (if present) will be activated for 15 seconds in direction central heating. During this time the pump is off.
Subsequently the pump is activated for 1 minute. Finally the 3-way-valve is diverted to sanitary. If there is no heatrequest within 24 hours, this procedure will be repeated to prevent blocking of the 3-way-valve and pump.

The control panel contains 6 buttons and a 4-digit display (*see figure*)

Heating system pressure

Your system is fitted with a heating safety valve set to 3 bar, with a pressure gauge. Read the heating circuit pressure on the combined temp/pressure gauge on the control panel:
Ensure that the water in the system is always pressurised. When cold, and the air in the system has been vented, the pressure gauge must show a pressure between 1 and 2 bar, depending on the height of the building. (1 bar = 5m / 1.5 bar = 10 m et 2 bar = 15 m).
To add water, open the filling valve. Close the filling valve tightly after filling. Vent the air in the system to get an accurate water pressure reading. (*See chapter, page 10: filling the hot water and heating circuits*).

Safety Valves

If water discharges from any of the safety valves, switch the boiler off and call a service engineer.

CONTROL SETTINGS

The boiler is controlled by the MCBA (microprocessor), with the control panel housed behind the front panel.

Standby Mode

Standby Mode is the normal operation display setting.

The first digit shows the boiler sequence. This sequence relates to current boiler status. The last two digits show the boiler temperature.

Sequence	Boiler status
0	Stand By, no heat request
1	Pre-purge, post-purge
2	Ignition
3	Burning in CH-mode
4	Burning in DHW-mode
5	Waiting for opening of Air pressure switch (max. 1 Min.) Waiting for closing of Air pressure switch (max. 2 x 1 Min.)
6	Burner off because the set-value has been reached
7	Overrun time pump in CH-mode
8	Overrun time pump in DHW-mode
9	Burner off because of protection: <ul style="list-style-type: none"> • "b08": airflowsensor did not close • "b18": T1 > 95 °C • "b19": T2 > 95 °C • "b24": T2 - T1 > 10,20 or 40 °C after 19 minutes • "b25": dT1/dt > Maximum Gradient T1 • "b26": Minimum gas or water pressure switch not closed • "b28": no fan signal • "b29": fan signal, incorrect fan rotation • "b30": T1 - T2 > Max. delta • "b33": NTC3 short circuit • "b35": NTC5 short circuit • "b38": NTC3 open circuit • "b40": NTC5 open circuit • "b52": T5 > T5max • "b61": airflowsensor closed • "b65": wait for fanstart
A	Internal control
G	Burner on for holding boiler warm
H	Burner-high function: Testmode max. RPM in CH-mode
L	Burner-low function: Testmode min. RPM in CH-mode
t	Burner on for manual fanspeed (servicing)

If the burner is turned off because of an extra protection, the display shows boiler-sequence 9 and the flow-temperature. This alternates with the error code eg. b26

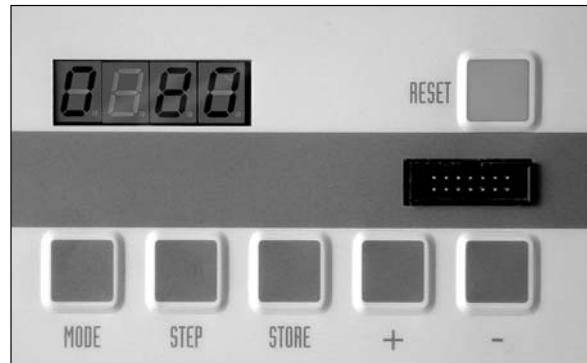

Changing the MCBA settings: Parameter mode

Proceed as follows:

- Press the "MODE" button once; the display will show "PARA".
- Press the "STEP" button once; the first digit is "1" and the last two show the setting for the first parameter.
- To change these last two, press "+" to increase and "-" to decrease.
- Save the new setting selected with the "STORE" button.
- To access the next parameter, press "STEP".
- Press the "MODE" button twice to return to standby mode.

List of accessible parameters:

Parameter N°	Description	Range
1	hot water setting	20 - 90 °C
2	"Hot water" system status	0 = OFF; 1 = ON
3	"Heating" system status	0 = OFF; 1 = ON
4	Heating setting	60 - 90 °C

Temperature measurement display: Info mode

Proceed as follows:

- Press the "MODE" button twice; the display will show "INFO".
- Press the "STEP" button once; the first digit is the measurement number and the last two its value.
- Press the "STEP" button to display the next measurement.
- To return to standby mode, press the "MODE" button once.

List of measurements available:

Measurement N°	Description
1	Temperature T1 - primary
2	Temperature T2 - primary
3	Temperature T3 - secondary
4	Outside temperature T4
5	Flue gas temperature T5
6	Setting for T1
7	Variation of T1 - °C/s
8	Variation of T2 - °C/s
9	Variation of T3 - °C/s

USER GUIDE

Safety shutdown

If an operating error develops, the system locks and the display flashes: the first digit shows the sequence the burner was in when the error occurred, the last two digits show the error code (see table below); the first digit and the next two flash alternately.



To reset the system:

- Press the “**RESET**” button on the MCBA display.
- If an error occurs again, call an approved heating engineer.

Table of error codes and corrective action

codes	Error description	Fault repair
00	No flame detected	- check wiring / - change electrode / - change MCBA
02	No ignition after 5 attempts	- check ignition electrode and its positioning
03-07	Internal error	- if the problem persists after 2 resets, change the MCBA
11	Eprom error	- if the problem persists after 2 resets, change the MCBA
12	24V fuse failure	- call engineer to check fuse
13-17	Internal error	- if the problem persists after 2 resets, change the MCBA
18	Primary temperature 1 > 110 °C	- check that sensor NTC1 is properly housed in its pocket - if so, change sensor NTC1
19	Primary temperature 2 > 110 °C	- check that sensor NTC2 is properly housed in its pocket - if so, change sensor NTC2
25	Primary temperature 1 gradient too high	- check that the shunt pump is operating, and if so vent the boiler
28	No fan signal	- if the fan is turning: <ul style="list-style-type: none">• check the PWM connection• if the problem persists after 2 resets, change the fan• if the problem persists after 2 resets, change the MCBA - if the fan is not turning: <ul style="list-style-type: none">• check the 230 Volt power to the fan
31	Short circuit in temperature 1 sensor	- change sensor NTC1
32	Short circuit in temperature 2 sensor	- change sensor NTC2
33	Short circuit in temperature 3 sensor	- change sensor NTC3
35	Short circuit in temperature 5 sensor	- change sensor NTC5
36	Temperature 1 sensor: circuit open	- check the connection of sensor NTC1 to the terminal strip - if the problem persists, change sensor NTC1
37	Temperature 2 sensor: circuit open	- check the connection of sensor NTC2 to the terminal strip - if the problem persists, change sensor NTC2
38	Temperature 3 sensor: circuit open	- check the connection of sensor NTC3 to the terminal strip - if the problem persists, change sensor NTC3
40	Temperature 5 sensor: circuit open	- check the connection of sensor NTC5 to the terminal strip - if the problem persists, change sensor NTC5
44	Internal error	- if the problem persists after 2 resets, change the MCBA
52	Flue gas temperature too high	
60	Error reading parameters	- if the problem persists after 2 resets, change the MCBA

Select an official installer to do the maintenance after 1 year of operation. This installer can, depending of the inspection and installation circumstances, determine the interval for future maintenance.

- Pull the plug. Remove the siphon, clean it, refill it with water and mount it again.
- Remove the inspection panel from the cover on top of the boiler.
- Remove the connectors from the fan and the gas valve.
- Unscrew the brass gas coupling near the gas valve.
- Unscrew the four M5 nuts, which fix the fan to the burner hood. Now the fan can be removed complete with gas valve and venturi.
- Unscrew the 8 nuts M6 of the burner hood en remove the burner hood.
- Now the burner can be removed. Inspect the fire chamber and the burner. The burner can be cleaned with a nylon brush (never use a steel brush) on the inside (so not on the side of the flame!)
- Replace the burner hood gasket if necessary.
- To finish mount all parts in reverse order.
- Pay attention to the right position of the burner, burner hood and fan.
- Light the boiler and check the %CO₂ both at max load and min load. If necessary re-adjust the %CO₂ (*see procedure at page 10*)

Resistance table temperature sensors

Temp. °C	R Ω	Temp. °C	R Ω
-20	98200	40	6650
-15	75900	45	5520
-10	58800	50	4610
-5	45900	55	3860
0	36100	60	3250
5	28600	65	2750
10	22800	70	2340
15	18300	75	1940
20	14700	80	1710
25	12000	85	1470
30	9800	90	1260
35	8050	95	1100
		100	950

The manufacturer may change parts of this manual without prior notice.

DESCRIPTION

PLANS

1. Aluminium-Silicium heat exchanger
2. Burner unit with fan, gas valve and venturi
3. Burner cover
4. Display
5. Inspection trap
6. Flow sensor
7. Return sensor
8. Water pressure switch
9. Gas pressure switch
10. Air-purge
11. Chimney connexion (100/150)

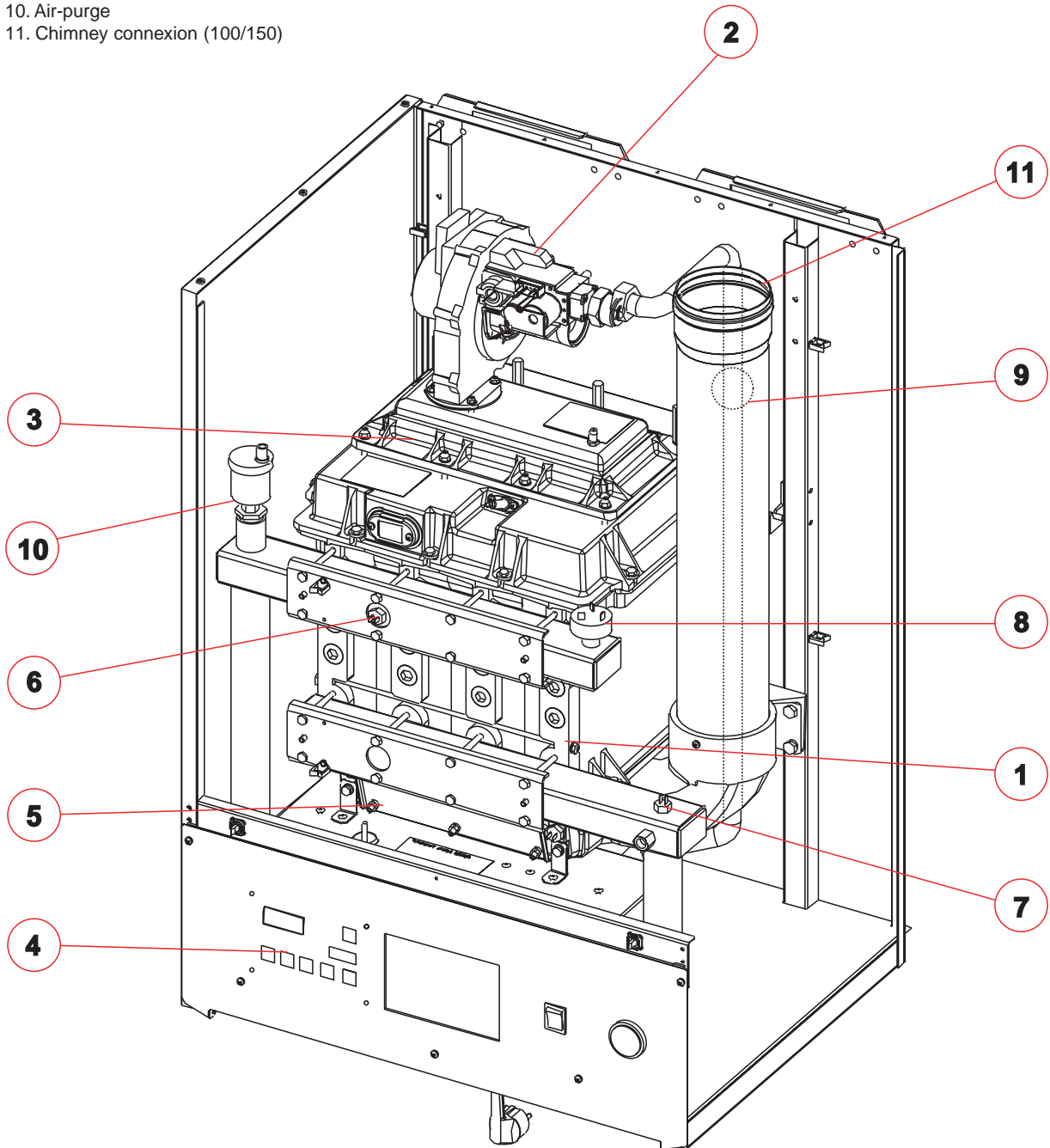

DIMENSIONS

			Prestige 47	Prestige 64	Prestige 85
A	Chimney	mm	100/150	100/150	100/150
B	Heating flow	∅	5/4"	5/4"	5/4"
C	Heating return	∅	5/4"	5/4"	5/4"
D	Gas supply	∅	3/4"	3/4"	3/4"
E	Siphon	∅ mm	25	25	25

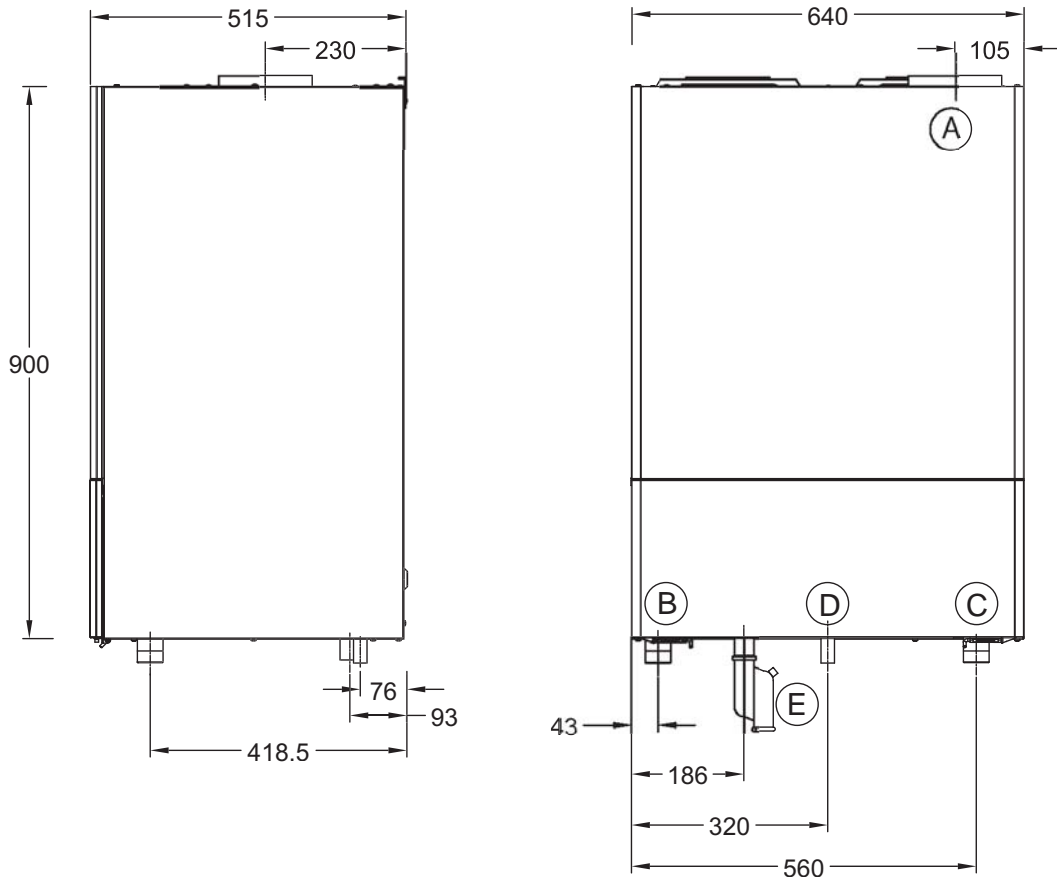

APPLIANCE CATEGORY

Country	Type	Prestige 47	Prestige 64	Prestige 85
BE		I2E(S)B , I3P	I2E(S)B, I3P	I2E(R)B , I3P
FR		I12Esi3P	I12Esi3P	I12Esi3P
GB		I12H3P	I12H3P	I12H3P
IE		I12H3P	I12H3P	I12H3P
PT		I12H3P	I12H3P	I12H3P
DE		I12ELL3B/P	I12ELL3B/P	I12ELL3B/P
LU		I12E3B/P	I12E3B/P	I12E3B/P
IT		I12H3B/P	I12H3B/P	I12H3B/P
AT		I12H3B/P	I12H3B/P	I12H3B/P
DK		I12H3B/P	I12H3B/P	I12H3B/P
GR		I12H3B/P	I12H3B/P	I12H3B/P
ES		I12H3P	I12H3P	I12H3P

Components

- F Fuse (6,3A)
- GV Gas valve
- M1 External 3-way valve 24 V AC 50Hz I_{rms} max = 350 mA
- M2 Heating pump
- M3 DHW pump
- MV Combustion air fan
- NTC1 Flow water temperature sensor
- NTC2 Return water temperature sensor
- NTC3 DHW sensor
- NTC4 Outdoor air sensor
- NTC5 Exhaust gas temperature sensor
- PC Inlet gas pressure switch
- PW Water pressure switch
- RC Remote control module
- SM External fault signal
- YC External gas isolating valve / burner-run indication
- RT Roomthermostat or night set-back
- ES External safety shut-off

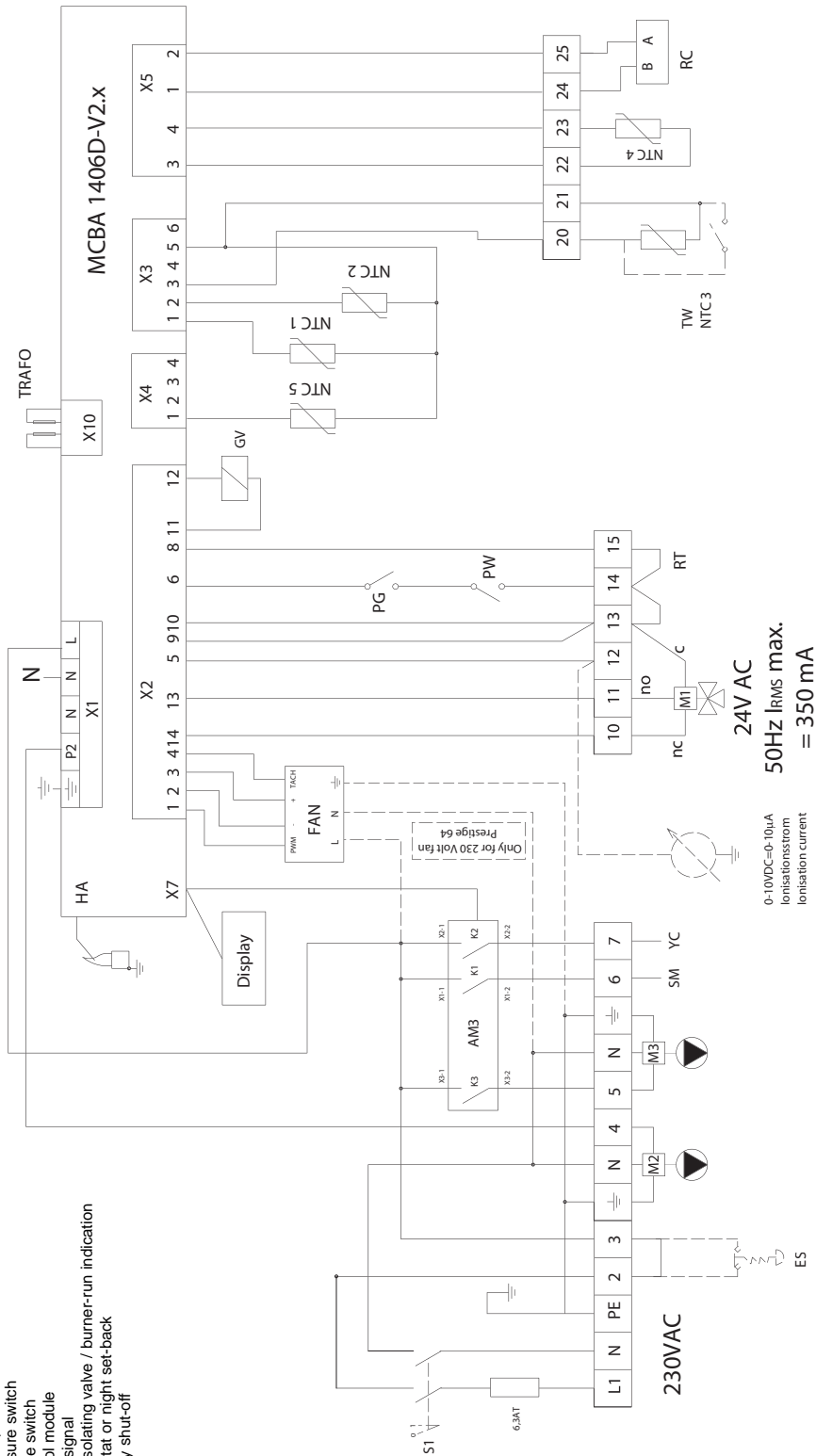

0-10VDC=0-10μA
ionisations from
ionisation current

24V AC
50Hz I_{rms} max.
= 350 mA

ELECTRICAL WIRING PRESTIGE 85

Components

- F Fuse (6,3A)
- GV Gas valve
- M1 External 3-way valve 24 V AC 50Hz I_{RMS} max = 350 mA
- M2 Heating pump
- M3 DHW pump
- MV Combustion air fan
- NTC1 Flow water temperature sensor
- NTC2 Return water temperature sensor
- NTC3 DHW sensor
- NTC4 Outdoor air sensor
- NTC5 Exhaust gas temperature sensor
- PC Inlet gas pressure switch
- PW Water pressure switch
- RC Remote control module
- SM External fault signal
- YC External gas isolating valve / burner-run indication
- RT Roomthermostat or night set-back
- ES External safety shut-off

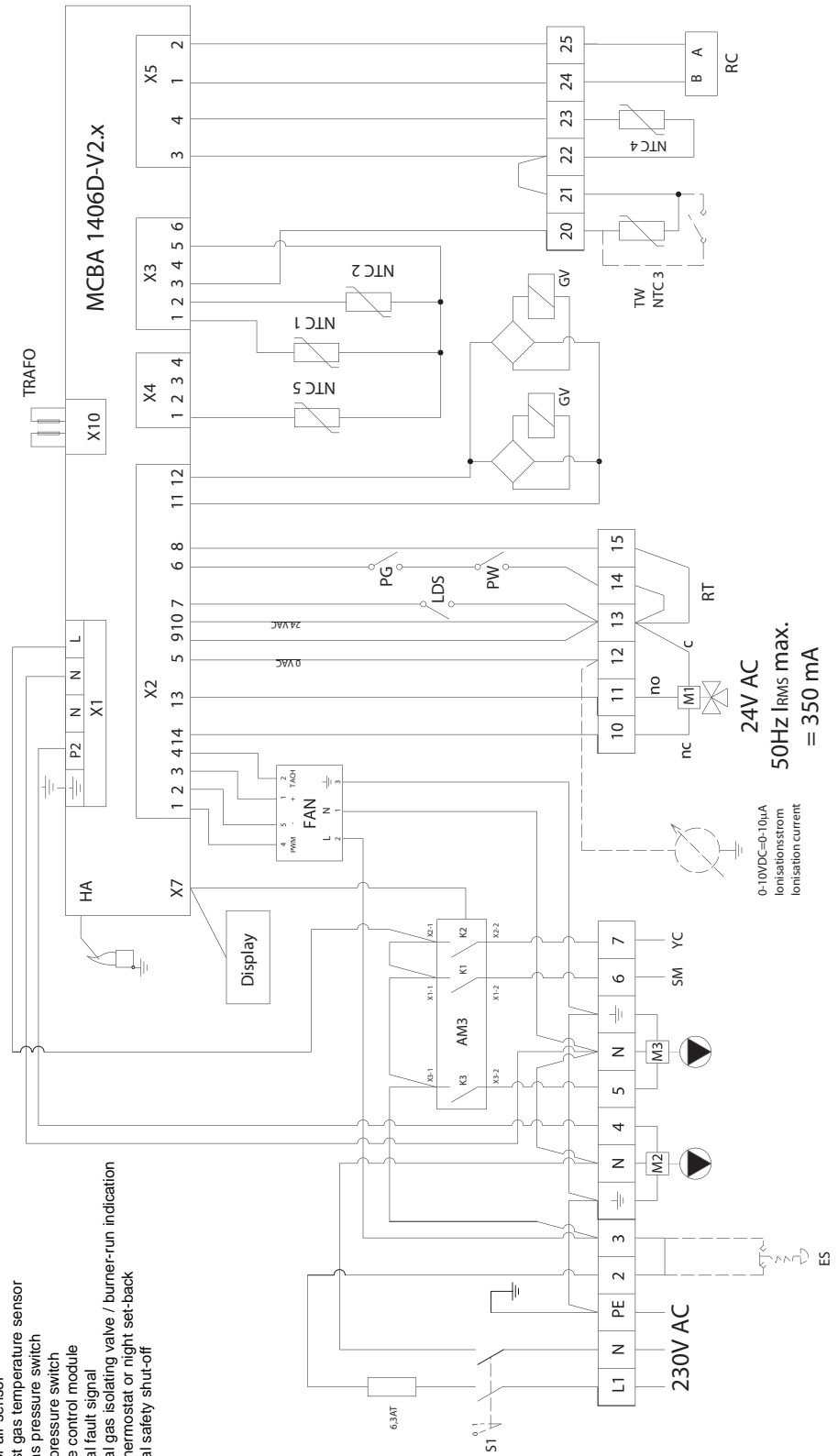

BOILER FEATURES

Central heating		Prestige 47	Prestige 64	Prestige 85
Nominal input max load	kW	45,0	60,0	80
Nominal input min load	kW	13,0	13,0	20
Nominal output max load 80/60	kW	43,7	58,9	78,2
Nominal output min load	kW	12,6	12,6	19,5
Efficiency max load 80/60	%	97,0	98,1	97,7
Efficiency min load 80/60	%	96,7	96,7	97,5
Efficiency max load 50/30	%	104,2	103,9	103,4
Efficiency min load 50/30	%	107,3	107,3	106,8
Efficiency max load 40/30	%	106,4	105,7	104,7
Norm efficiency 75/60 (RAL-UZ 61)	%	106,7	106,1	105,6
Norm efficiency 40/30 (RAL-UZ 61)	%	110,0	109,8	108,5
Flue gas				
		Prestige 47	Prestige 64	Prestige 85
Norm emission CO/Nox (RAL-UZ 61)	Mg/kwh	14/45	27/55	30/60
Nom emission CO/Nox (Gaskeur SV)	Mg/kwh	20/23	29/27	35/25
Temperature max load 75/60	°C	58	64	64
Temperature max load 40/30	°C	40	63	-
Mass flow flue gas max load	Kg/h	68	91	121
Max flue resistance	mbar	1,00	1,40	1,5
Max concentric flue length Ø 100 / Ø 150	m	34	24	25
Max concentric flue length Ø 80 / Ø 125	m	17	12	-
Gas				
		Prestige 47	Prestige 64	Prestige 85
appliance category	(1)	see page 9	see page 9	see page 9
Supply pressure for E-Gas	mbar	20	20	20
Supply pressure for LL-Gas	mbar	20	20	20
Supply pressure for LPG	mbar	50	50	50
Gas consumption G20	m³/h	1,4 - 4,7	1,4 - 6,3	2,1 - 8,3
Gas consumption G25	m³/h	1,6 - 5,4	1,6 - 7,2	2,4 - 9,7
Gas consumption GPL	kg/h	1,0 - 3,5	1,0 - 4,7	1,5 - 6,0
Setting max load / min load for natural gas	% CO₂	8,9 / 8,7	8,9 / 8,7	9,2 / 9,0
Setting max load / min load for propane	% CO₂	10,6 / 10,3	10,6 / 10,3	10,6 / 10,3
Setting max load / min load for butane	% CO₂	11,6 / 11,3	11,6 / 11,3	11,6 / 11,3
(1) Depending on country of destination				
Water				
		Prestige 47	Prestige 64	Prestige 85
Max flow temperature	°C	90	90	90
Contents boiler	L	8	8	10
Max water pressure boiler	bar	4	4	4
Pressure drop heat exchanger ($\Delta T=20 / \Delta T=10$)	mbar	20 / 70	50 / 180	70 / 270
Weight				
		Prestige 47	Prestige 64	Prestige 85
	Kg	87	88	101
Dimensions				
		Prestige 47	Prestige 64	Prestige 85
Width	mm	640	640	640
Depth	mm	490	490	490
Height	mm	900	900	900
Electrics				
		Prestige 47	Prestige 64	Prestige 85
Protection classification		IP 40	IP 40	IP 40
Mains	V/Hz	230 / 50	230 / 50	230 / 50
Electrical consumption	W	51	84	120

INSTALLATION RECORD

Date installed: _____	Flue gas T° : _____	Model : _____
% CO₂ (min. load) : _____	Efficiency : _____	Serial number : _____
% CO₂ (max. load) : _____	Gas pressure : _____	Heating system pressure setting : _____
<input type="checkbox"/> Gas _____		
<input type="checkbox"/> LPG _____	Name and signature : _____	

Date installed: _____	Flue gas T° : _____	Model : _____
% CO₂ (min. load) : _____	Efficiency : _____	Serial number : _____
% CO₂ (max. load) : _____	Gas pressure : _____	Heating system pressure setting : _____
<input type="checkbox"/> Gas _____		
<input type="checkbox"/> LPG _____	Name and signature : _____	

Date installed: _____	Flue gas T° : _____	Model : _____
% CO₂ (min. load) : _____	Efficiency : _____	Serial number : _____
% CO₂ (max. load) : _____	Gas pressure : _____	Heating system pressure setting : _____
<input type="checkbox"/> Gas _____		
<input type="checkbox"/> LPG _____	Name and signature : _____	

Date installed: _____	Flue gas T° : _____	Model : _____
% CO₂ (min. load) : _____	Efficiency : _____	Serial number : _____
% CO₂ (max. load) : _____	Gas pressure : _____	Heating system pressure setting : _____
<input type="checkbox"/> Gas _____		
<input type="checkbox"/> LPG _____	Name and signature : _____	

Date installed: _____	Flue gas T° : _____	Model : _____
% CO₂ (min. load) : _____	Efficiency : _____	Serial number : _____
% CO₂ (max. load) : _____	Gas pressure : _____	Heating system pressure setting : _____
<input type="checkbox"/> Gas _____		
<input type="checkbox"/> LPG _____	Name and signature : _____	

Date installed: _____	Flue gas T° : _____	Model : _____
% CO₂ (min. load) : _____	Efficiency : _____	Serial number : _____
% CO₂ (max. load) : _____	Gas pressure : _____	Heating system pressure setting : _____
<input type="checkbox"/> Gas _____		
<input type="checkbox"/> LPG _____	Name and signature : _____	

SERVICE RECORD

Date installed: _____ Flue gas T° : _____ Model : _____
% CO₂ (min. load) : _____ Efficiency : _____ Serial number : _____
% CO₂ (max. load) : _____ Gas pressure : _____ Heating system pressure setting : _____
 Gas _____
 LPG _____ Name and signature : _____

Date installed: _____ Flue gas T° : _____ Model : _____
% CO₂ (min. load) : _____ Efficiency : _____ Serial number : _____
% CO₂ (max. load) : _____ Gas pressure : _____ Heating system pressure setting : _____
 Gas _____
 LPG _____ Name and signature : _____

Date installed: _____ Flue gas T° : _____ Model : _____
% CO₂ (min. load) : _____ Efficiency : _____ Serial number : _____
% CO₂ (max. load) : _____ Gas pressure : _____ Heating system pressure setting : _____
 Gas _____
 LPG _____ Name and signature : _____

Date installed: _____ Flue gas T° : _____ Model : _____
% CO₂ (min. load) : _____ Efficiency : _____ Serial number : _____
% CO₂ (max. load) : _____ Gas pressure : _____ Heating system pressure setting : _____
 Gas _____
 LPG _____ Name and signature : _____

Date installed: _____ Flue gas T° : _____ Model : _____
% CO₂ (min. load) : _____ Efficiency : _____ Serial number : _____
% CO₂ (max. load) : _____ Gas pressure : _____ Heating system pressure setting : _____
 Gas _____
 LPG _____ Name and signature : _____

Date installed: _____ Flue gas T° : _____ Model : _____
% CO₂ (min. load) : _____ Efficiency : _____ Serial number : _____
% CO₂ (max. load) : _____ Gas pressure : _____ Heating system pressure setting : _____
 Gas _____
 LPG _____ Name and signature : _____



excellence in hot water

www.acv-world.com

INTERNATIONAL

ACV international n.v
KERKPLEIN, 39
B-1601 RUISBROEK - BELGIUM
TEL.: +32 2 334 82 20
FAX: +32 2 378 16 49
E-MAIL: international.info@acv-world.com

BELGIUM

ACV BELGIUM nv/sa
KERKPLEIN, 39
B-1601 RUISBROEK-BELGIUM
TEL.: +32 2 334 82 40
FAX: +32 2 334 82 59
E-MAIL: belgium.info@acv-world.com

CHILE

ALBIN TROTTER Y ACV LTDA
SAN PABLO 3800
QUINTA NORMAL - SANTIAGO - CHILE
TEL.: +56 2 772 01 69
FAX: +56 2 772 92 62/63
E-MAIL: chile.info@acv-world.com

CZECH REPUBLIC

ACV CR SPOL. s.r.o
NA KRECKU 365
CR-109 04 PRAHA 10 - CZECH REPUBLIC
TEL.: +420 2 720 83 341
FAX: +420 2 720 83 343
E-MAIL: ceskarepublika.info@acv-world.com

DEUTSCHLAND

ACV WÄRMETECHNIK GMBH & CO KG
GEWERBEGBIET GARTENSTRASSE
D-08132 MÜLSEN OT. JACOB - DEUTSCHLAND
TEL.: +49 37601 311 30
FAX: +49 37601 311 31
E-MAIL: deutschland.info@acv-world.com

ARGENTINA

TECNO PRACTICA
ALFEREZ BOUCHARD 4857
1605 CARAPACHAY - BUENOS AIRES
TEL.: +54 11 47 65 33 35
FAX: +54 11 47 65 43 07
E-MAIL: jchas@tecnopractica.com

BRAZIL

SIMETAL INDUSTRIA E COMERCIO DE FERRAMENTAS LTDA
RUA GERSON ANDREIS 535
95112 - 130 CAXIAS DO SUL - BRAZIL
TEL.: +55 54 227 12 44
FAX: +55 54 227 12 26
E-MAIL: export@simetal.com.br

BULGARIA

PROXIMUS ENGINEERING LTD
7 BIAL KREM STR.
9010 VARNNA - BULGARIA
TEL.: +359 52 500 070
FAX: +359 52 301 131
E-MAIL: info@proximus-bg.com

CHINA

BEIJING HUADIAN HT POWER TECHNOLOGY DEVELOPMENT CO. LTD
ROOM B-912, TOWER B, COFCO PLAZA
Nº. 8, JIANGUOMENNEI AVENUE
BEIJING 100005 - PEOPLE'S REPUBLIC OF CHINA
TEL.: +86 10 652 30 363/393 EXT 101
FAX: +86 10 652 27 071
E-MAIL: li.zheng@acv-world.com

DENMARK

VARMEHUSET
FRICHSVEJ 40 A
8600 SILKEBORG - DENMARK
TEL.: +45 86 82 63 55
FAX: +45 86 82 65 03
E-MAIL: vh@varmehuset.dk

ESPAÑA

ACV ESPAÑA
C/ANTONIO GAUDI, 3
E-08349 CABRERA DE MAR - ESPAÑA
TEL.: +34 937 595 451
FAX: +34 937 593 498
E-MAIL: spain.info@acv-world.com

FRANCE

ACV FRANCE sa
31, RUE AMPERE - Z.I MI - PLAINE
F-69680 CHASSIEU - FRANCE
TEL.: +33 4 72 47 07 76
FAX: +33 4 72 47 08 72
E-MAIL: france.info@acv-world.com

ITALIA

ACV ITALIA
VIA MALPIGHI 6
I-48018 FAENZA (RA) - ITALIA
TEL.: +39 0546 62 25 15
FAX: +39 0546 62 25 05
E-MAIL: italia.info@acv-world.com

NEDERLAND

ACV NEDERLAND bv
POSTBUS 350
NL-2980 AJ RIDDERKERK - NEDERLAND
TEL.: +31 180 42 10 55
FAX: +31 180 41 58 02
E-MAIL: nederland.info@acv-world.com

POLAND

ACV POLSKA sp. z o.o.
UL. WITOSA 3
87 - 800 WWCOWAWEK - POLAND
TEL.: +48 54 412 56 00
FAX: +48 54 412 56 01
E-MAIL: polska.info@acv-world.com

ESTONIA

TERMOMX AS
TAHE 112A
51013 TARTU - ESTONIA
TEL.: +372 736 73 39
FAX: +372 736 73 44
E-MAIL: termomx@termomx.ee

GREECE

ESTIAS
MARASLI STREET 7
54248 THESSALONIKI - GREECE
TEL.: +30 23 10 31 98 77 / +30 23 10 32 03 58
FAX: +30 23 10 31 97 22
E-MAIL: info@genikithermanson.gr

ÎLE MAURICE

SOTRATECH
29, RUE MELDRUM
BEAU BASSIN - ÎLE MAURICE
TEL.: +230 46 76 970
FAX: +230 46 76 971
E-MAIL: stech@intnet.mu

LITHUANIA

UAB "GILIUS IR KO"
SAVARNORIU PR. 192
3000 KAUNAS - LITHUANIA
TEL.: +370 37 308 930
FAX: +370 37 308 932

MAROC

CASATHERM
PLACE EL YASSIR
20300 CASABLANCA - MAROC
TEL.: +212 22 40 15 23
FAX: +212 22 24 04 86

MOLDAVIA

STIMEX - PRIM S.R.L.
STR BUCURESTI, 60A
2012 CHISINAUJ - MOLDAVIA
TEL.: +37 32 22 46 75
FAX: +37 32 27 24 56
E-MAIL: stimex@slavik.mldnet.com

PORTUGAL

BOILERNOX LDA
RUA OUTEIRO DO POMAR
CASAL DO CEGO, FRACÇÃO C,
PAVILHÃO 3 - MARRAZES
2400-402 LEIRIA - PORTUGAL
TEL.: +351 244 837 239/40
FAX: +351 244 823 758
E-MAIL: boilernox@mail.telepac.pt

RUSSIA

ACV RUSSIA
1/9, MALYI KISELNYI
103031 MOSCOW - RUSSIA
TEL.: +7 095 928 48 02 / +7 095 921 89 79
FAX: +7 095 928 08 77
E-MAIL: russia.info@acv-world.com

SLOVAK REPUBLIC

ACV SLOVAKIA s.r.o.
PLUHOVÁ 49
831 04 BRATISLAVA - SLOVAK REPUBLIC
TEL.: +421 2 444 62 276
FAX: +421 2 444 62 275
E-MAIL: slovakia.info@acv-world.com

UK

ACV UK Ltd
ST. DAVID'S BUSINESS PARK
DALGETY BAY - FIFE - KY11 9PF
TEL.: +44 1383 82 01 00
FAX: +44 1383 82 01 80
E-MAIL: uk.info@acv-world.com

USA

TRIANGLE TUBE PHASE III
FREEWAY CENTER - 1 TRIANGLE LANE
BLACKWOOD NJ 08012 - USA
TEL.: +1 856 228 8881
FAX: +1 856 228 3584
E-MAIL: sales@triangletube.com

ÖSTERREICH

PROTHERM HEIZUNGSTECHNIK GmbH
TRAUNJUFERSTRASSE 113
4052 ANSFELDEN - ÖSTERREICH
TEL.: +43 7229 804 82
FAX: +43 7229 804 92
E-MAIL: protherm@nexttra.at

ROMANIA

SC TRUST EURO THERM SA
D.N PIATRA NEAMT - ROMANIA
km 2 C.P 5 O.P 3 jud. Neamt
5600 PIATRA NEAMT - ROMANIA
TEL.: +40 233 20 62 06
FAX: +40 233 20 62 00
E-MAIL: office@eurotherm.ro

SLOVENIA

Z'MAJ d.o.o.
CESTA OF 49
1420 TRBOVLJE - SLOVENIA
TEL.: +386 356 32 830
FAX: +386 356 32 831
E-MAIL: jjeraj@zmej.si

SWEDEN

WÄRMEPRODUKTER I KLIPPAN AB
TEMPLAREGÅTAN 7
26435 KLIPPAN - SWEDEN
TEL.: +46 435 184 10
FAX: +46 435 184 02
E-MAIL: varmeprodukter.se@telia.com

TUNISIE

SO.CO.ME CHAUMAX
BOÎTE POSTALE N°44
1002 TUNIS - TUNISIE
TEL.: +216 71 78 15 91
FAX: +216 71 78 87 31

UKRAINE

UKRTEPLOSERVICE LTD
PR. LAGUTENKO 14
83086 DONETSK - UKRAINE
TEL.: +38 062 382 60 47/48
FAX: +38 062 335 16 89
E-MAIL: ges@kias.net