

## SCHIEDEL SWIFT AIR CHIMNEY SYSTEM IN ENERGY EFFICIENT HOUSE

The heated air circulates within the house. The stove and the boiler do not take air from inside the house so no warm air is lost through the chimneys.

**- Schiedel, enabling energy efficiency.**

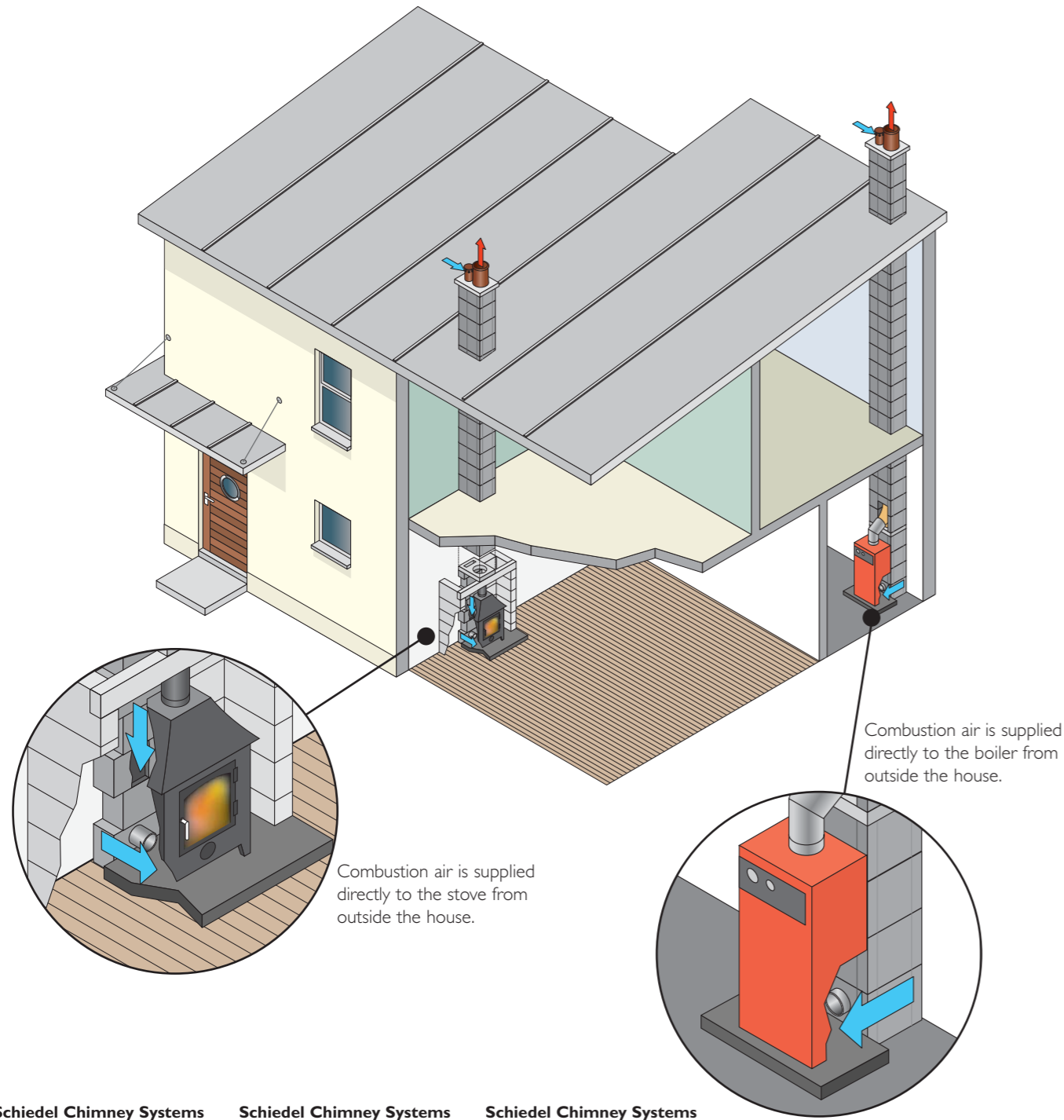

**Schiedel Chimney Systems**  
Crowther Estate  
Washington  
Tyne & Wear NE38 0AQ  
Tel. +44 (0)191 416 1150  
Fax. +44 (0)191 415 1263  
info@schiedel.co.uk  
www.schiedel.co.uk

**Schiedel Chimney Systems**  
Washingbay Road  
Coalisland  
Co. Tyrone BT71 4ND  
Tel. +44 (0)28 8774 0436  
Fax. +44 (0)28 8774 7430  
info@schiedel.co.uk  
www.schiedel.co.uk

**Schiedel Chimney Systems**  
14 Haviland Road  
Ferndown Industrial Estate  
Wimborne, Dorset BH21 7RF  
Tel. +44 (0)1202 861650  
Fax. +44 (0)1202 861632  
info@schiedel.co.uk  
www.schiedel.co.uk



**A** ✓  
**B**  
**C**  
**D**

**ENABLING ENERGY EFFICIENCY**

## THE GUIDE TO CERAMIC CHIMNEY SYSTEMS AND LINERS

GB Issue 2, March 2011





## ENERGY EFFICIENCY AND CHIMNEYS

In the drive for more efficient homes the latest revision of the building regulations mean that all new houses must comply with tighter rules, aimed at reducing energy consumption and carbon emissions from houses by a further 25%.

By choosing an appropriate heating appliance and an efficient chimney/flue system, you can help meet the Government's target without compromising on the cosy focal point that truly makes a house a home.

### IMPROVE ENERGY EFFICIENCY AND REDUCE CARBON EMISSIONS

The aim is to move away from less efficient heating appliances to ones with higher efficiencies and to use energy sources that produce less carbon. There is a common misunderstanding that the more efficient the appliance, the less carbon it uses. This is not the case. An electric fire is deemed to be 100% efficient but electricity is a high emitter of CO<sub>2</sub>. Wood on the other hand is effectively carbon neutral and when used in an efficient appliance will significantly reduce the carbon output from a house. Under the new regulations stoves can now be used as secondary or primary heating. A house can be fitted with two primary heating systems, for example a condensing gas or oil boiler and a linked stove system to maximise the carbon saving benefits of the wood burning stove.



### CHIMNEY SPECIFICATION

The chimney plays an important role in the overall performance of a heating system. An efficient heating appliance requires a well designed and consistently insulated chimney to perform at optimum efficiency. This is where the Schiedel Swift chimney systems come in. The Schiedel Swift systems provide continuous insulation along the entire length of the chimney ensuring that the chimney remains warm during the operation of the appliance.

Having spent time and money heating the air in a room the last thing you want is for that hot air to escape up the chimney. With an open fire it is calculated that 40 cubic meters of air will pass up the chimney each hour. The Schiedel Swift Open Fire systems can be fitted with the optional damper that can be closed when the fire is not lit. This halves the assumed air loss in the SAP calculation to 20 cubic meters per hour. (SAP is the calculation method used to determine the amount of CO<sub>2</sub> produced by a house). Installing a stove and a chimney with a diameter of less than 200mm diameter will also have an air loss of only 20m<sup>3</sup>.

The Schiedel Swift Air goes one step further and when used in conjunction with a stove designed to take all its combustion air from outside the house reduces the air loss in the SAP to zero.

- Greater energy efficiency
- Lower carbon emissions from burning wood
- Meet the requirements of Document L and SAP

## CHOOSING YOUR APPLIANCE AT THE PLANNING STAGE IS NOW CRUCIAL

Both primary and secondary heating **MUST** be specified at the design stage if the required carbon savings are to be realised. This is a big change in our thinking as the choice of appliance would usually have been left until building was complete or the house occupied. If the choice is not made before the build, the SAP programme will default to the worst case scenario.

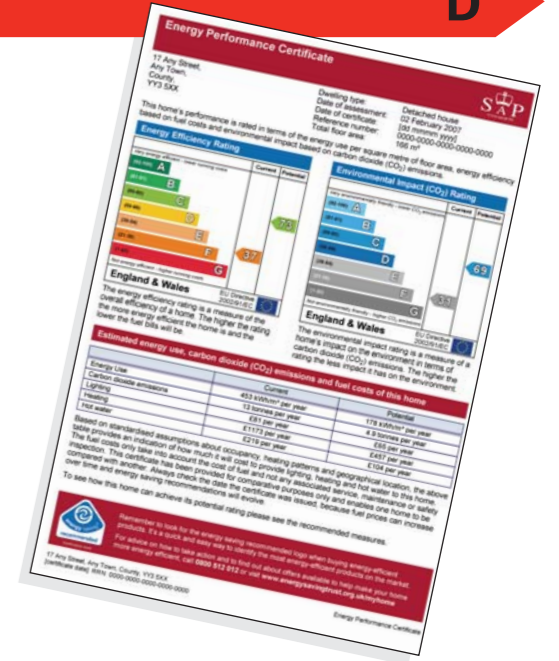
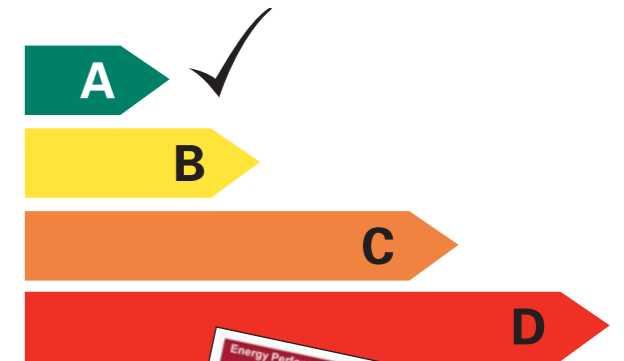

### CARBON SAVING AND FUEL CHOICE

A common misunderstanding is the more efficient the appliance the greater the carbon saving. The carbon dioxide produced by the fuel used in the appliance has a major impact on carbon emissions. For example, an electric fire is assumed to be 100% efficient but, electricity is more carbon intensive than other fuels. As a result it is more environmentally friendly to use a 70% efficient stove burning wood than an electric fire. Significant carbon savings can be achieved by burning wood in a closed appliance like a log burning stove or a pellet boiler.





## THE SCHIEDEL CERAMIC RANGE

Schiedel Chimney Systems is the leading supplier of chimney systems in Europe and in the UK. The Schiedel Ceramic Range consists of:

### CERAMIC CHIMNEY SYSTEMS

The Schiedel Swift chimney systems are designed for speed and ease of construction. Their consistent insulation properties mean that they keep the flue gases warm allowing them to escape to the atmosphere even at low temperatures.

The systems are also designed to work with more efficient appliances, completing an energy efficient solution. The systems have BBA and Irish Agrement approval.



Swift Air Chimney Block with external air shaft

### CERAMIC LINERS

Schiedel ceramic round liner systems are available in a range of diameters. The diameter of the liner is determined by the outlet pipe of the appliance or by the cross sectioned area of the fire opening.

For an open fire a liner system will consist of a fireback, lintel or throating unit, liners, possible bends, insulation and a chimney pot. A high temperature sealant should be used to seal the liners in place.

Each of the liner systems on the following pages detail the components required.

Schiedel ceramic flue liners are manufactured in accordance with BSEN1457:1999 and comply with the requirements of Document J of the building regulations.

The liners are classified as AINI meaning that the liners will function at a nominal working temperature of 600°C for 10 minutes. NI indicates that they are suitable in condensing and non-condensing chimneys.



### NOTICE PLATE AND CHECKLIST

Document J requires that the chimney installer complete an installation checklist and leave a permanent notice plate detailing the type of chimney and uses to which it can be put. To make life easier Schiedel has created a checklist and notice plate pack.

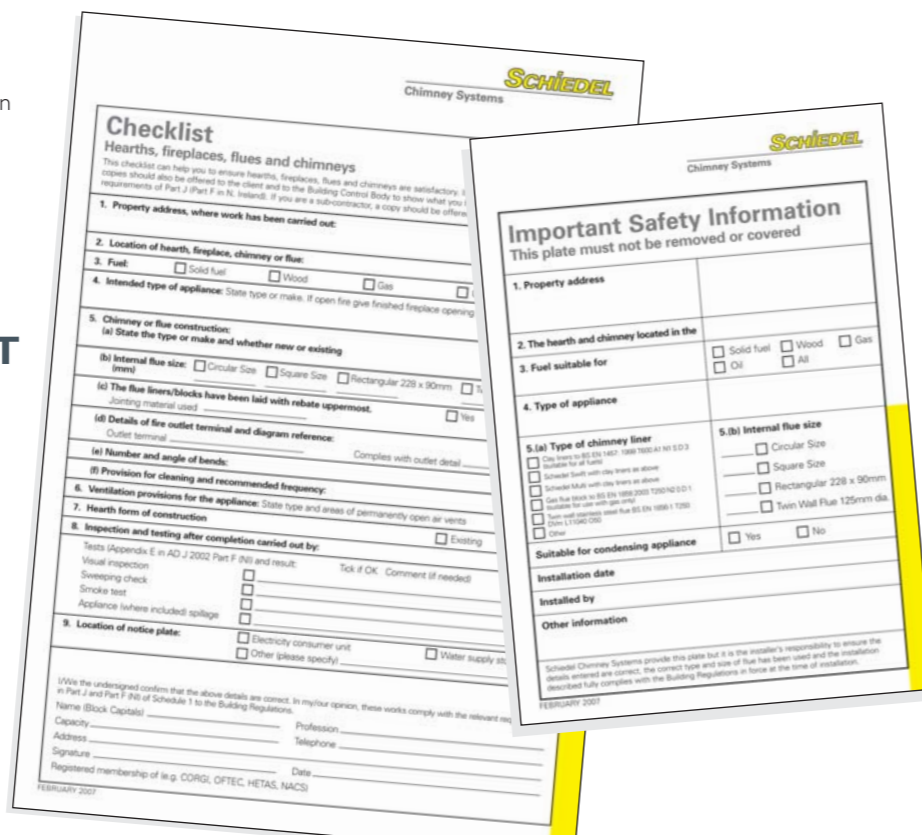

## THE SCHIEDEL CHIMNEY SYSTEM CONCEPT

Traditionally, chimneys are completely constructed on site with separate components supplied by different manufacturers. This process is labour intensive and makes it difficult to ensure consistent insulation. By contrast the Schiedel Swift offers modular, prefabricated units to speed construction and facilitate consistent quality standards.

### THE CONCEPT INVOLVES A MODULAR 3-LAYER INSULATED CHIMNEY SYSTEM:



#### 1st Layer

A high quality flue liner, made of fireclay, tested to EN1457.



#### 2nd Layer

A flexible insulation board designed to maintain the temperature of the flue gases and allow them to pass freely up the chimney. It also allows the flue liner to expand and contract without damage.



#### 3rd Layer

A lightweight chimney block which safely encases the whole system and provides additional insulation.

### KEY FEATURES

- Designed for speed of construction.
- Suitable for Timber Frame, Steel Frame and Masonry construction. Solutions have been specifically designed to meet the requirement of timber framed construction.
- Modular units for easy assembly on site.
- Suitable for all fuels - gas, oil and solid fuels.
- A high temperature ceramic sealant is provided in tubes for ease of application.
- Superior Insulation - The consistency of the insulation maintains the temperature of the flue gases allowing them to pass freely up the chimney. Back filling of insulation is not required.
- The use of a chimney tray is always recommended.
- The high quality fireclay flue liner complies with the European Standard EN1457.
- BBA Certificate No. 03/4019



## SCHIEDEL SWIFT OPEN FIRE

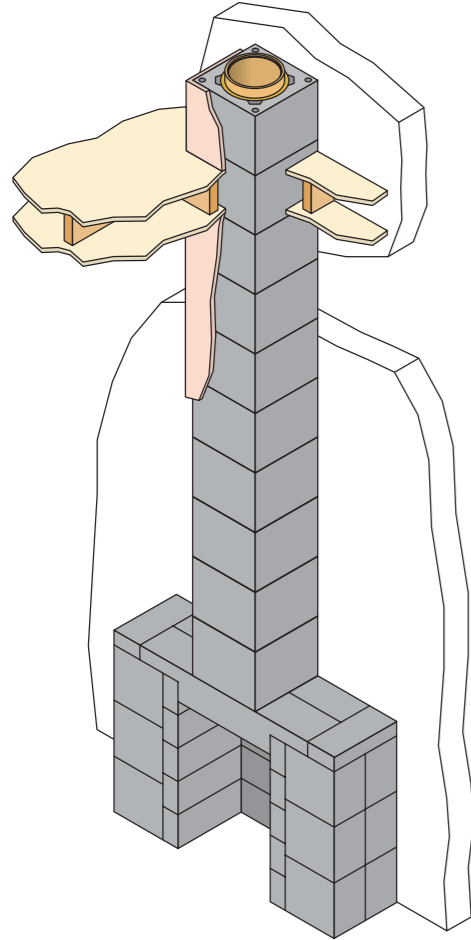
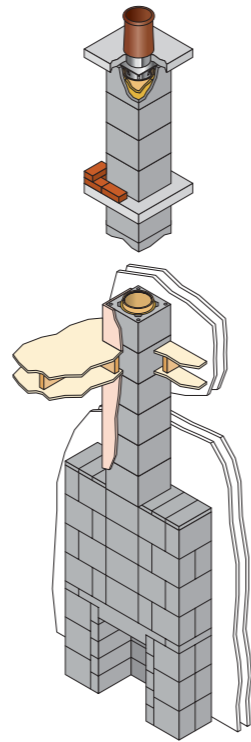
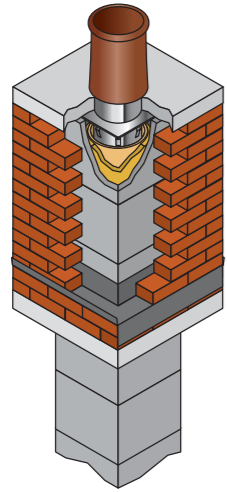

### INTERNAL OPEN FIRE

Internal Swift - Single chimney for timber frame, steel frame or masonry constructions. Available with a corbel for 3 brick wide (675mm) brick or rendered stack or as a Plain Swift without the corbel stack (stack 400mm wide)

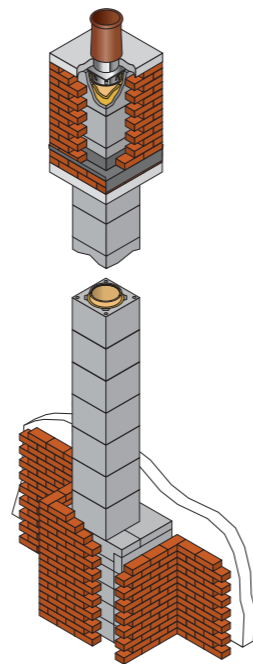

### EXTERNAL OPEN FIRE

External Swift - Suitable for a single chimney where the chimney is on the outside of the building. A bend kit can be used to tumble in on one side.

### TRADITIONAL OPEN FIRE

Schiedel Swift offers modular, prefabricated units to speed construction and facilitate consistent quality standards. Form the firechest and chimney breast as normal, then use the traditional Swift Kit to build the chimney. All the chimney components from the lintel to the chimney pot are in the kit.

## SCHIEDEL SWIFT STOVE

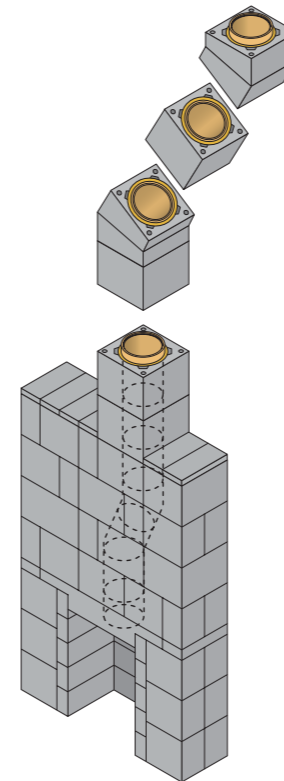
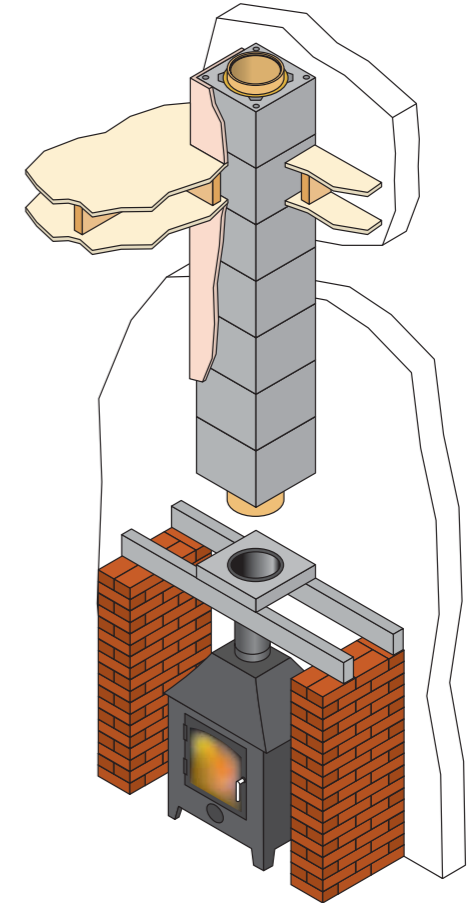
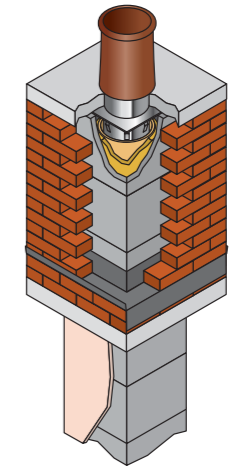

### BENDS AND OFFSETS

It is recommended that a chimney be constructed as a straight chimney. Were a bend is required, for example to move the chimney into a corner in the first floor; a Schiedel Swift bend kit can be used.

The Breast Bend kit allows the flue to be moved from 200 - 400mm in the chimney breast.

The Standard Bend Kit allows the flue to be moved horizontally as far as required so long as it is supported in the traditional manner.

### RECESS STOVE

Chimney system to suit oil, gas and solid fuel stoves. As the height of the stove recess depends on the room style and the size of the appliance the stove system starts with the lintels. The system incorporates a starter unit to connect with the outlet pipe of the stove. The same stack options are available as the open fire. The stove option is available in 150mm, and 200mm internal diameters.



## SCHIEDEL SWIFT AIR

Manufactured to EN13063-1:2003-8 **CE**

In an A rated house the combustion air required for wood burning appliance like a stove burning logs or wood pellets must be supplied directly to the stove from outside the house. These appliances are called room sealed as they are manufactured not to take air from the room. The Schiedel Swift Air provides all the benefits of the Schiedel Swift and in addition neatly and simply delivers the external air to the stove.

The alternative to Schiedel Swift Air is low level or under floor ducting ideally with air supplies from opposite sides of the house.

The Schiedel Swift Air solution avoids this by ducting the air through an external air shaft in the chimney.

Available in 150mm and 200mm internal flue diameters. The size of the chimney block is the same for each flue diameter - 500mm x 360mm x 330mm high.

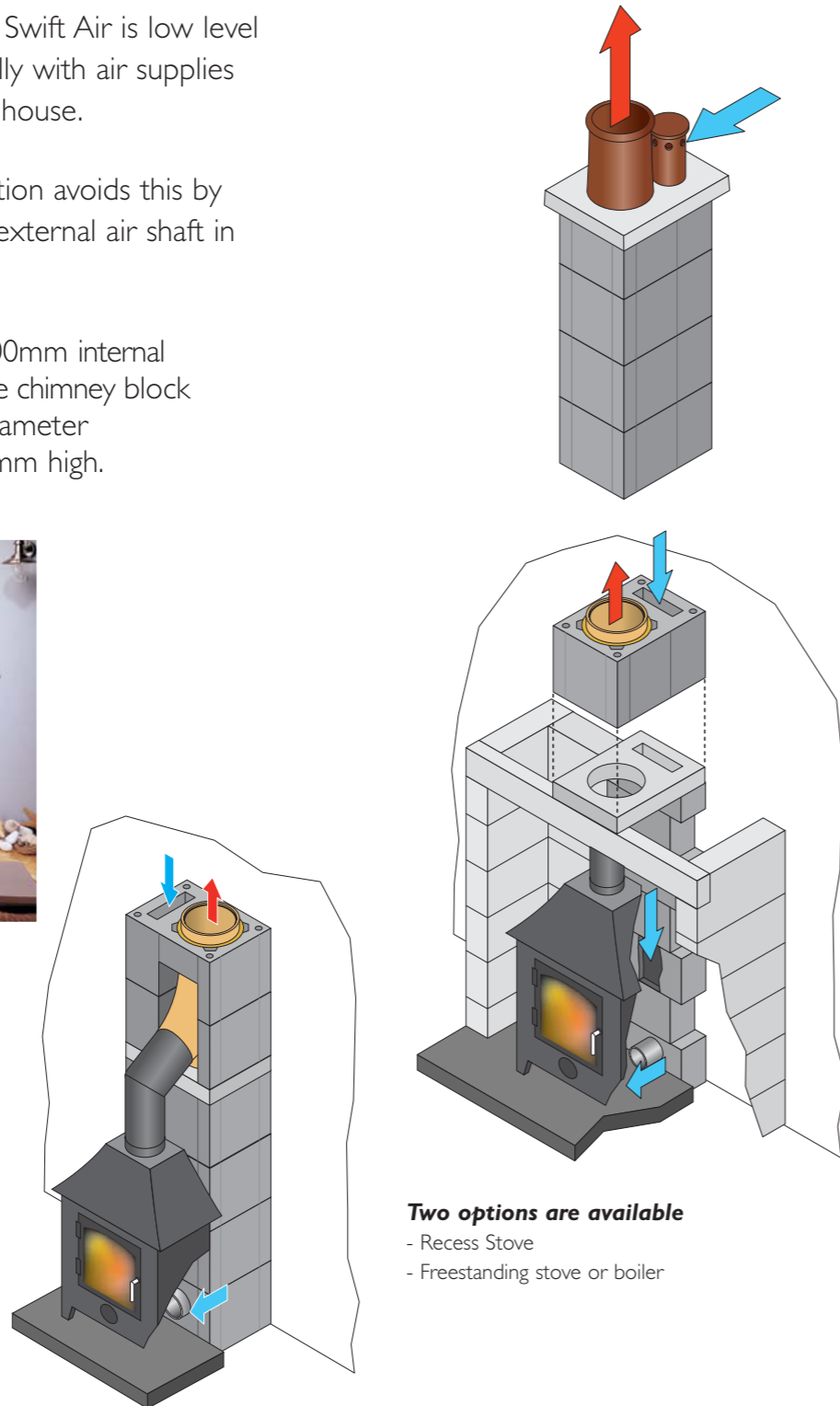

**Two options are available**  
- Recess Stove  
- Freestanding stove or boiler

## SCHIEDEL SWIFT AIR CHIMNEY SYSTEM IN ENERGY EFFICIENT HOUSE

The heated air circulates within the house. The stove and the boiler do not take air from inside the house so no warm air is lost through the chimneys.

**- Schiedel, enabling energy efficiency.**

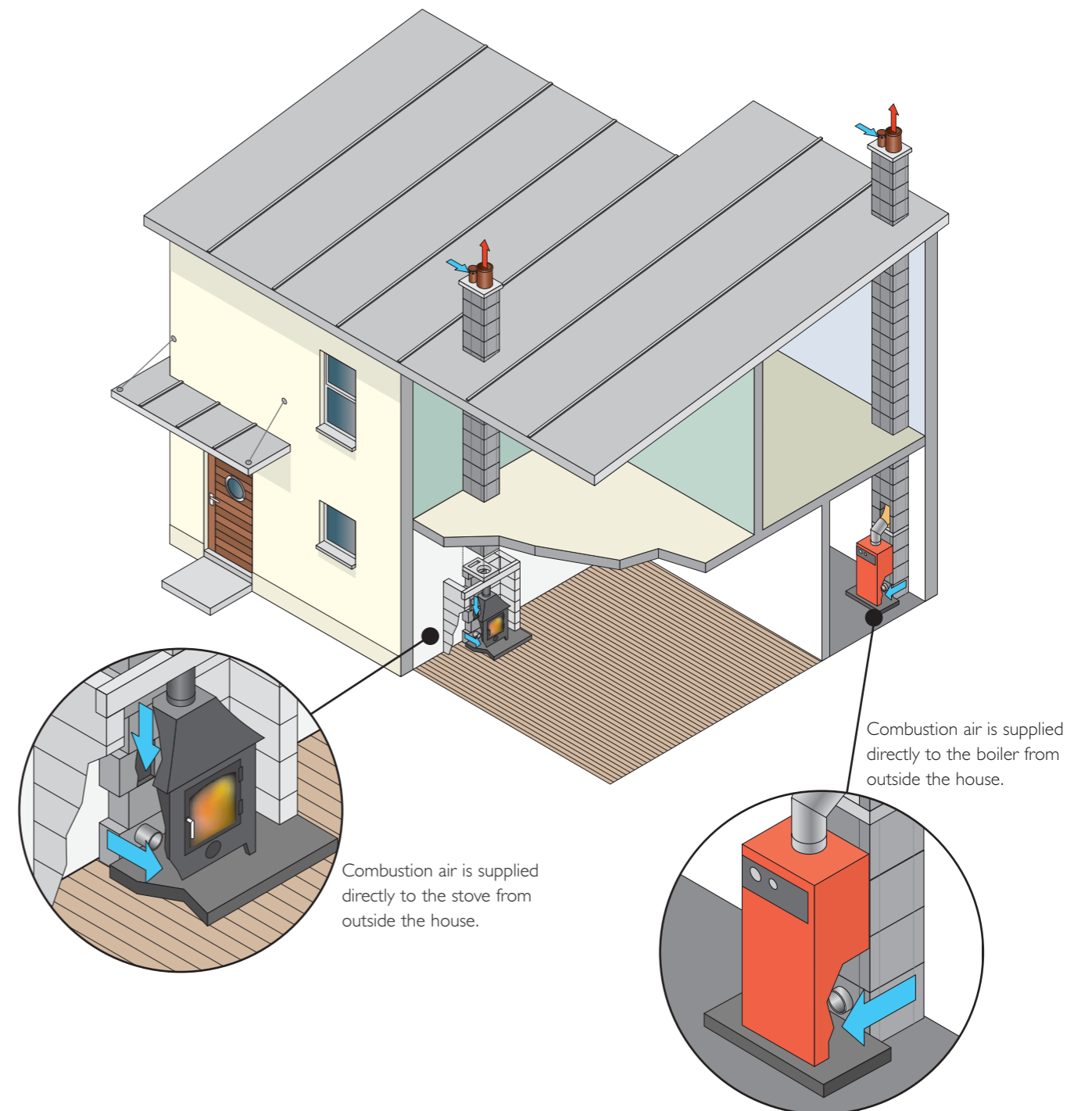

# CIRCULAR CERAMIC FLUE LINERS

Manufactured to EN1457: 1999 Clay Ceramic Flue Liners - AINI

## 150mm Round Liner System

Suitable for use with closed appliances with a flue outlet not exceeding 150mm internal diameter.

Code	Description	Pallet
AA16	180mm high x 150mm id Liner	40
A03	400mm high x 150mm id Liner	147
B03	22.5° x 150mm id Bend	75
B05	37.5° x 150mm id Bend	75
AA21	45° x 150mm id T Liner	
C40120	150mm Support block	
U00150	150mm Stainless steel adaptor	

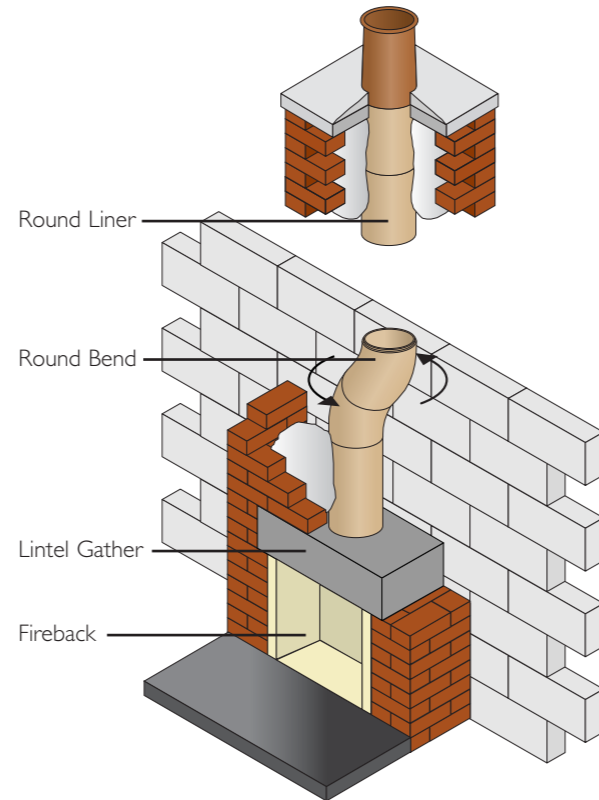

## 200mm Round Liner System

Suitable for use with large closed appliances and open fires with a fire opening of 500mm wide x 550mm high.

Code	Description	Pallet
CS+R15	Gather - 800w x 440d x 215mm h Max clear span 600mm	
A05	400mm high x 200mm id Liner	90
A30	180mm high x 200mm id Liner	90
B08	22.5° x 200mm id Bend	52
B10	37.5° x 200mm id Bend	52

## 225mm Round Liner System

Suitable for large closed appliances and open fires with a fire opening of 500mm wide x 550mm high.

Code	Description	Pallet
CR16	Gather - 800w x 440d x 215mm h Max clear span 600mm	
A06	400mm high x 225mm id Liner	90
A31	180mm high x 225mm id Liner	90
B19	22.5° x 225mm id Bend	52
B20	37.5° x 225mm id Bend	52

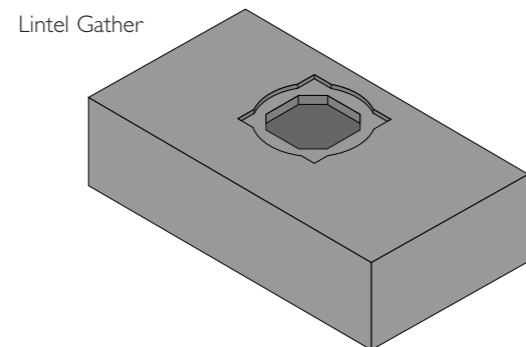
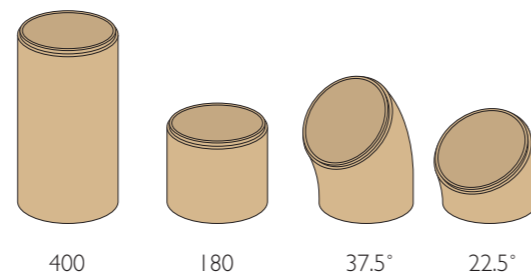

## Offset Table for 150, 200 and 225mm id Round Ceramic Bends

Total Offset (mm)	Bends		Straight Lengths		Combined Height
	22.5	37.5	180	400	
113	2				604
139					563
179	2		1		762
190		2			572
224			1		721
255	2		2		945
270	2			1	983
300		2	1		715
314			2		888
322	2		3		1111
328				1	915
338	2		1	1	1148
391	2		4		1277
402			3		1044
409		2	2		858
421	2			2	1352
422			1	1	1079
434		2		1	889
459	2		5		1444

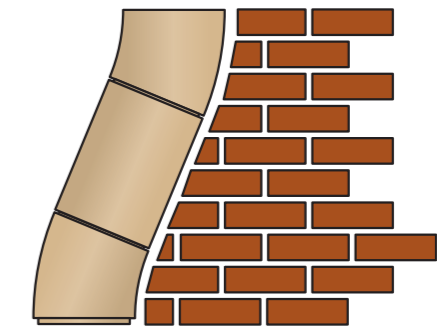
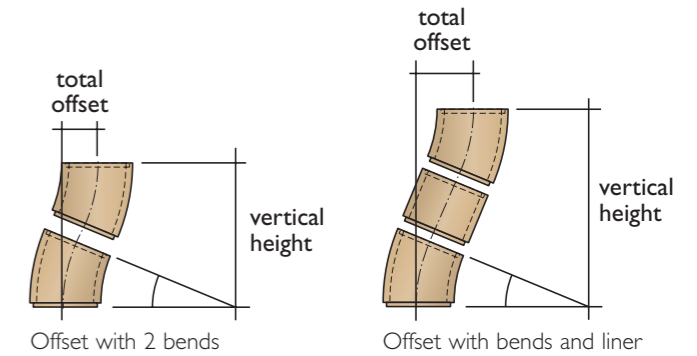

**SUPPORTING AN OFFSET**  
The bends and liners that make up an offset must be supported adequately

# CERAMIC CHIMNEY POTS AND ACCESSORIES

Code	Description
<b>Terracotta Chimney Pots</b>	
CP150	150mm id 450mm high roll top
CP200	200mm id 450mm high roll top
CP220	225mm id 300mm high roll top
CP225	225mm id 450mm high roll top

<b>Chimney Top Guards</b>	
RGCI	Chimney Topguard Buff 150 - 250mm id
RGTI	Chimney Topguard Terracotta 150 - 250mm id

<b>Accessories</b>	
FB450	450mm milner scored clay fireback
50301	50 litre Leca (0.05m³)
I7500100	Rapid Ceramic Sealant
C Plate	Chimney Data Plate
Pellet	Smoke Pellets (6 per tube)

