

BOILER RANGE

General Information for
**POWRMATIC/SIME Range of GAS
& OIL Fired Boilers**

10—281 kW (34,000 — 960,000 Btu/h)

Atmospheric Gas 10 — 281 kW

Oil 20 — 205 kW

Forced Draught Gas 20 — 205 kW

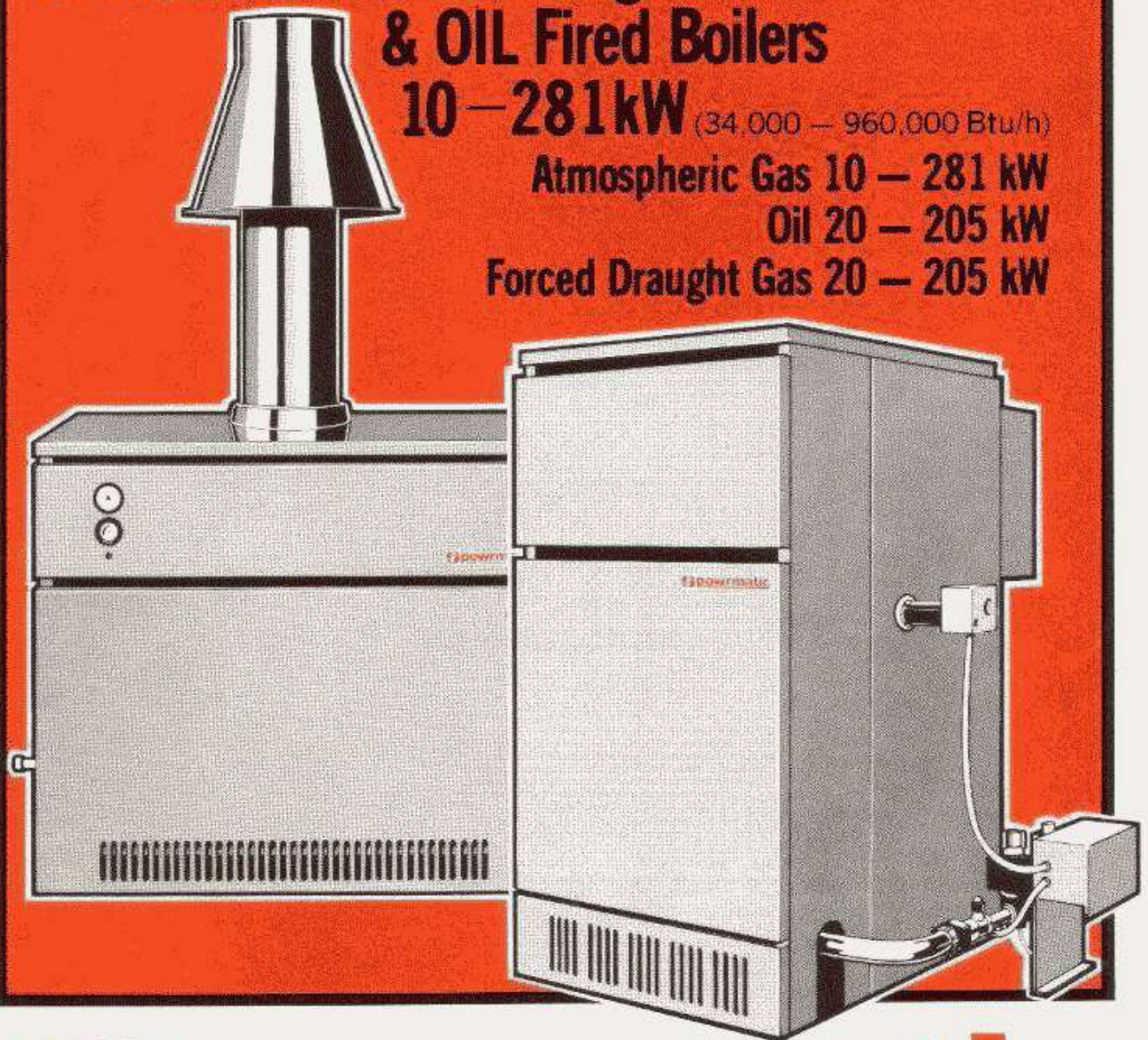

powrmatic

General Information

Range

The POWRMATIC SIME range of cast iron sectional boilers cover the output range 10 — 281 kW (34,000 — 960,000 Btu/h).

The ATMOSPHERIC GAS RANGE, identified by the model types RM, RMG and RS cover the full range 10 — 281 kW.

The OIL and FORCED DRAUGHT GAS FIRED MODELS, identified by the model types AR, 1R and 2R cover the range 20 — 205 kW.

Boilers for LPG and special gases to order.

Construction

All boilers are manufactured to current British and European standards for safety, performance and construction.

Every boiler in the range is supplied with the cast iron sectional waterway fully assembled and tested at works. On the smaller sizes the boiler is delivered to site with the casing and burner assembly already fitted.

Full safety and operating controls are fitted to each boiler: instrument panel on all except the RM range. Insulated casing supplied with each boiler.

Application

All boilers suitable for heating and indirect hot water supply and for use on LTHW and MTHW systems.

Operating Pressures

All boilers are suitable for working pressure of 58 p.s.i. (134 ft. head: 0.4 N/mm²).

Electrical Requirements

All boilers and burners are suitable for a single phase 240 volt 50 Hz A.C. electrical supply and connected via a double pole isolator and the appropriate fuse.

Availability

Boilers available ex stock from POWRMATIC or through U.K. stockists network.

Commissioning

Commissioning service available from POWRMATIC Service Department.

Spares

Available throughout the UK through POWRMATIC spares stockists network.

NOTE: This is a general information leaflet on the POWRMATIC-SIME boiler range. For more detailed information please contact the Head Office or Area Representative. Detailed technical data is available on all the ranges mentioned in this general sales leaflet.

RM Series (British Gas Tested and Certified)

Brief description: small commercial size atmospheric gas boiler. RM 32 & 42 with integral down draught diverter: RM 52, 62 and 72 with external down draught diverter and cast iron boiler. The outer panels are finished in a white stoved enamel.

Full safety and operating controls and suitable for either gravity or pumped circulation. Boiler delivered to site fully assembled and tested with casing fitted.

Boilers suitable for natural gas as standard; LPG and towns to order. Boilers suitable for modular application — all connections at the rear of the boiler.

Dimensional Details

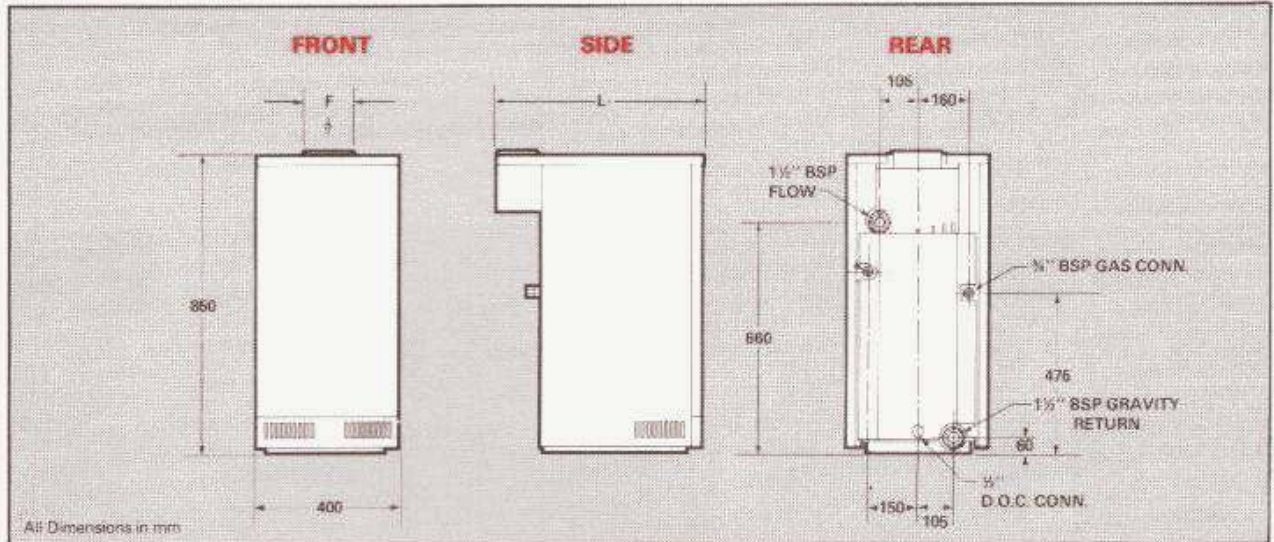

Dimensional Details

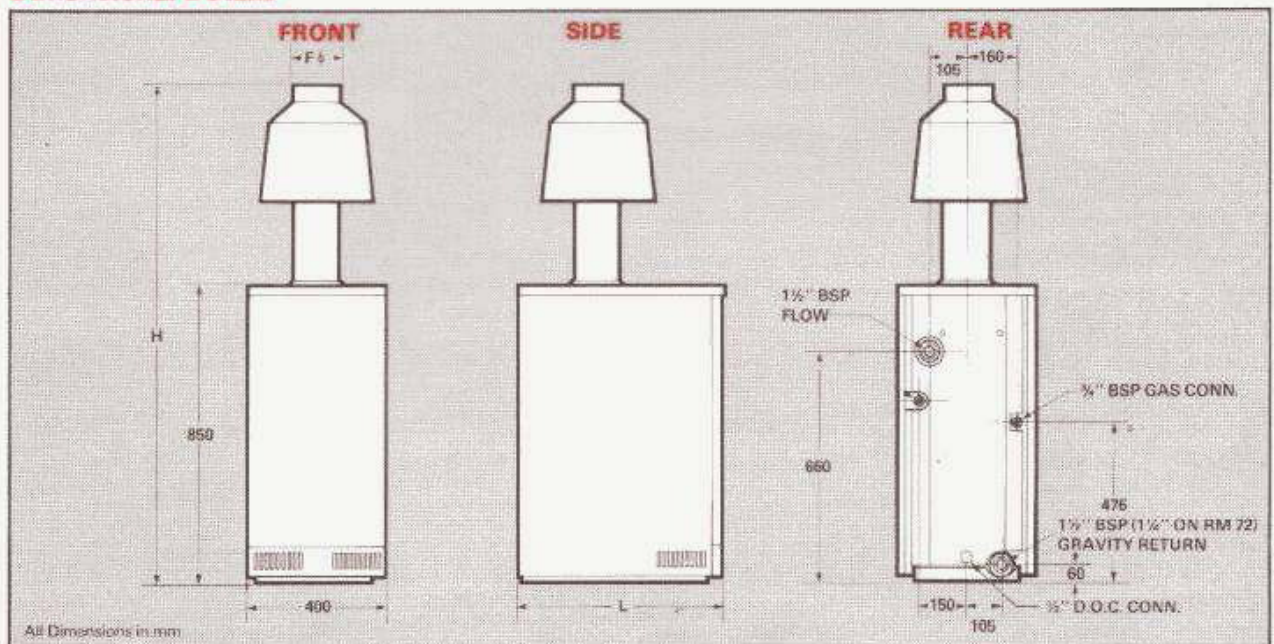

General Data

Boiler Ref	Heat Output		Gas Rate		Weight kg	Water Content Lt	Water Resistance 18°C t mm wg	Flue Gas m ³ /h Volume at 15°C · 4% CO ₂	Draught Req'd mm	Dimension		
	kW	Btu/h	m ³ /h	ft ³ /h						F mm	L mm	H mm
RM 22	10	34125	1.19	42	66	7	—	34	1	110	505	—
RM 32	18	61450	2.14	76	90	10	—	61	1	130	595	—
RM 42	26.46	90250	3.10	109	114.6	13	25	94	1	150	722	—
RM 52	37	126250	4.40	155	138.4	16	38	134	1	180	670	1440
RM 62	49	167200	5.83	206	161.6	19	43	172	1	180	770	1440
RM 72	58	197900	6.90	244	185.3	22	48	203	1	200	870	1700

RMG Series

(British Gas Tested and Certified)

Brief description: Eminently suitable for the medium size commercial application where a compact atmospheric gas boiler is required. Blue stove enamel insulated case with instrument panel. Full safety and operating controls, incorporating multi-functional control for reliable operation. Suitable for pumped circulation only. Boiler delivered to site fully assembled and tested with casing fitted – only down-draught diverter requires site fixing.

Boilers suitable for natural gas as standard; LPG, towns and special gases to order.

Dimensional Details

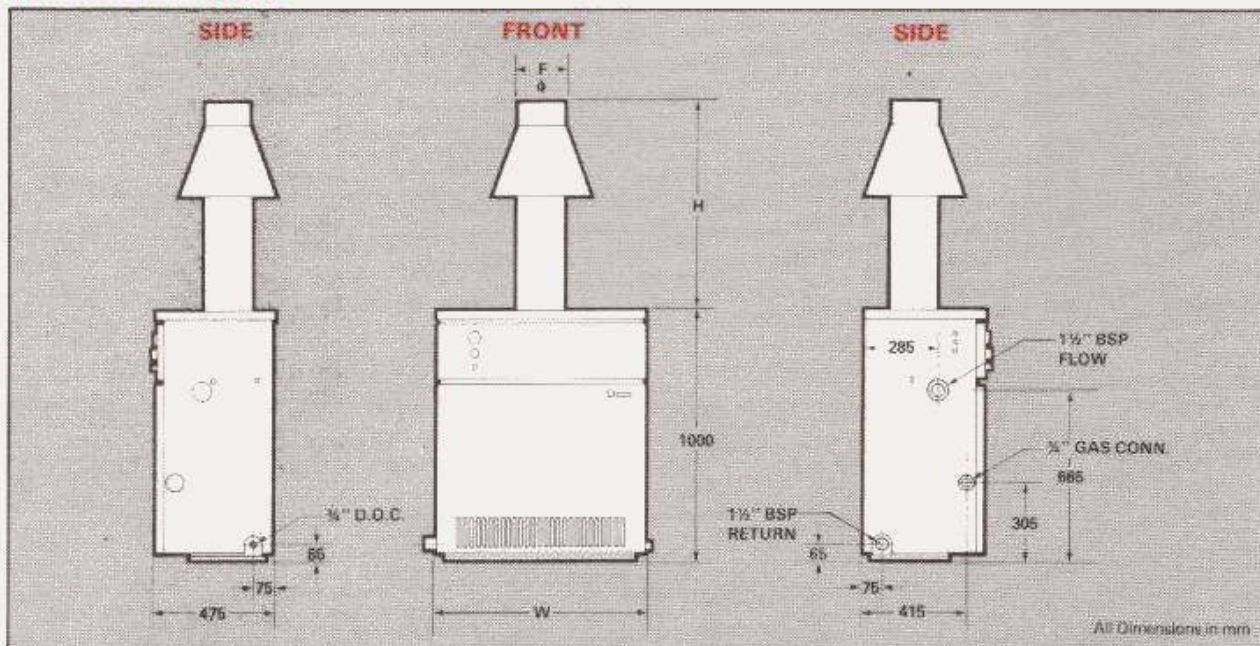

General Data

Boiler Ref	Heat Output		Gas Rate*		Weight kg	Water Content Lt	Water Resistance 10°C Δt mm wg	Flue Gas m ³ /h Volume at 15°C : 4%CO ₂	Draught req'd mm	H mm	W mm	F mm
	kW	Btu/h	m ³ /h	ft ³ /h								
RMG 8	72	246,000	8.69	307	238	27	420	258	1	825	840	200
RMG 9	84	287,000	10.25	362	266	30	559	295	1	865	940	225
RMG 10	96	328,000	11.58	409	294	33	709	335	1	865	1040	225

Adequate clearance must be allowed around boiler for access and performance: Rear 50mm; Front 1000mm; Sides 600mm; Top 1250mm (above casing).

RS Series

(British Gas Tested and Certified)

Brief description: the largest of the atmospheric gas range for the larger commercial and industrial application. Blue stove enamel insulated case with externally side mounted gas control assembly. The RS range is fully automatically controlled with an intermittent pilot. Suitable for pumped circulation only. Boiler delivered to site with fully assembled and tested waterways but it is necessary to fit burner and control assembly, casing and integral down-draught diverter on site. Boilers can be supplied with waterway broken down for site assembly, using push nipples and tie rods to special order. Boilers suitable for natural gas as standard LPG and town gas to special order.

Dimensional Details

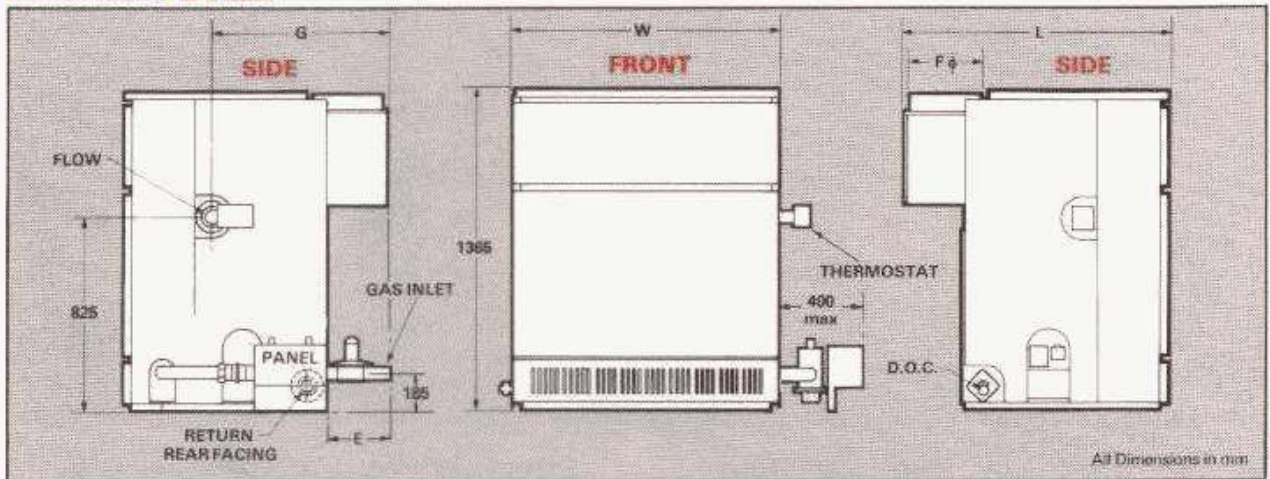

Flow and Return Connections: 2" BSP female.

Gas Connection: 1" BSP RS6 – RS10
1 1/2" BSP RS11 – RS14

Drain Off Cock: 3/4" BSP

Note: F & R connections on LHS as standard. These can be changed on site but F & R must always be on same side of the boiler – not opposite.

General Data

Boiler Ref	Heat Output		Gas Rate*		Weight kg	Water content lt	Water resistance 10°C Δt mm wg	Flue Gas m ³ /h volume at 15°C: 4% CO ₂	Draught req'd mm	W mm	L mm	E mm	F φ mm	G mm
	kW	Btu/h	m ³ /h	ft ³ /h										
RS 6	107	365,100	13	458	387	58	290	372	1	700	1110	315	250	730
RS 7	130	443,700	15.6	549	452	68	335	446	1	810	1110	315	250	730
RS 8	150	511,800	18.2	641	582	77	406	519	1	920	1110	315	250	730
RS 9	173	590,300	20.4	720	647	87	460	593	1	1030	1110	315	250	730
RS 10	195	665,350	22.8	804	712	96	505	667	1	1145	1140	345	300	760
RS 11	216	737,000	25.6	902	777	106	546	740	1	1255	1140	345	300	760
RS 12	230	784,800	28.4	1000	842	115	582	814	1	1370	1190	395	350	810
RS 13	264.2	901,500	31.2	1099	907	125	610	888	1	1480	1190	395	350	810
RS 14	281	958,800	34	1199	972	134	638	961	1	1590	1190	395	350	810

Adequate clearance must be allowed around boiler for access and performance: Rear 75mm; Front & Top 1000mm; Sides 600mm.

AR Series

Brief description: small commercial size sectional boiler where either oil or forced draught gas burners are required; suitable for utility or boiler room the boiler can be fitted with either Nu-way or Riello burners. Full safety and operating controls with boiler instrument panel. Blue stove enamel insulated casing with covered burner ensures minimum noise level with maximum efficiency. Boiler delivered to site with fully assembled waterway, the casing, smokehood, pre-wired burner and controls require site fixing. Burners suitable for natural gas and 35 sec. oil as standard. LPG and kerosene (28 sec.) versions to order.

Dimensional Details

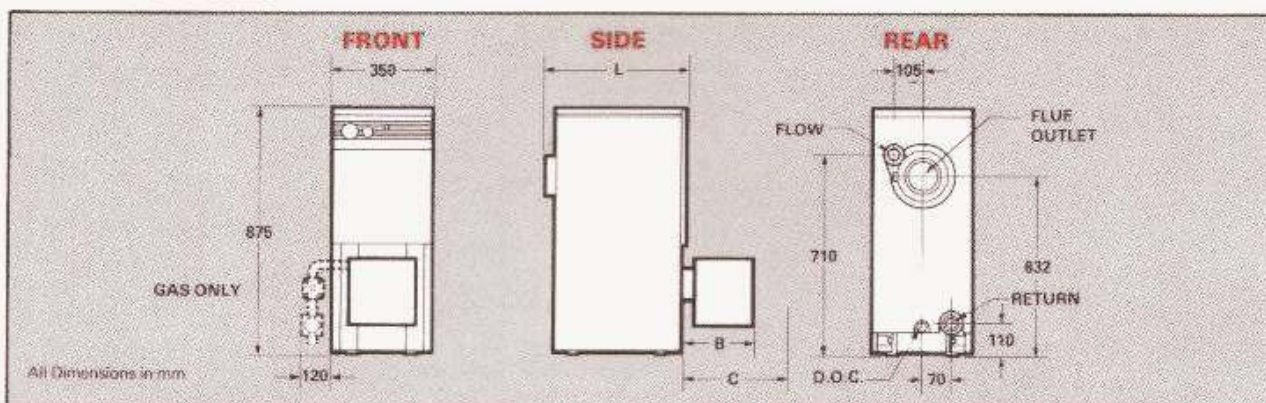

Flue connection

125mm ϕ socket 25mm deep

C = Clearance for burner removal

Riello oil: 340mm max
Riello gas: 400mm max
Nu-way oil: 450mm max
Nu-way gas: not available

Flow & return connections

1 1/2" BSP female

Draw off cock connection

1/2" BSP female

Fuel connections

Riello oil: 3/8" BSP
Riello gas: 1" BSP
Nu-way oil: 1/4" BSP
Riello oil and gas: 0.7 amps
Nu-way oil only: 0.82 amps

B = Burner projection

Riello oil: 235mm max
Riello gas: 300mm max
Nu-way oil: 350mm max
Nu-way gas: not available

Running currents

General Data

Boiler Ref	Heat Output		Firing Rate		Weight inc. Burner kg	Water Content ft	Water Resistance 10°C Δt mm wg	Flue Gas* m ³ /h volume at 15°C : 9% CO ₂	Draught req'd mm	L mm
	kW	Btu/h	Oil L/h	Gas m ³ /h						
AR 3	20	68,000	2.3	2.3	115	19	12	37	2	395
AR 4	29	99,000	3.0	3.4	141	23	20	54	2	495
AR 5	40	136,000	4.5	4.8	168	27	31	74	2	595

*Flue gas volume for gas : oil volume approx. 10% less. Flue gas temp. 200°C approx.

Adequate clearance must be allowed around the boiler for access: Rear, sufficient room to connect water and flue; Front & Side 500mm.

1R and 2R Series (1R Series British Gas Tested and Certified [with Riello only]).

Brief description: medium commercial size sectional boiler, similar in design and specification to the AR and for fully pumped systems only.

Dimensional Details

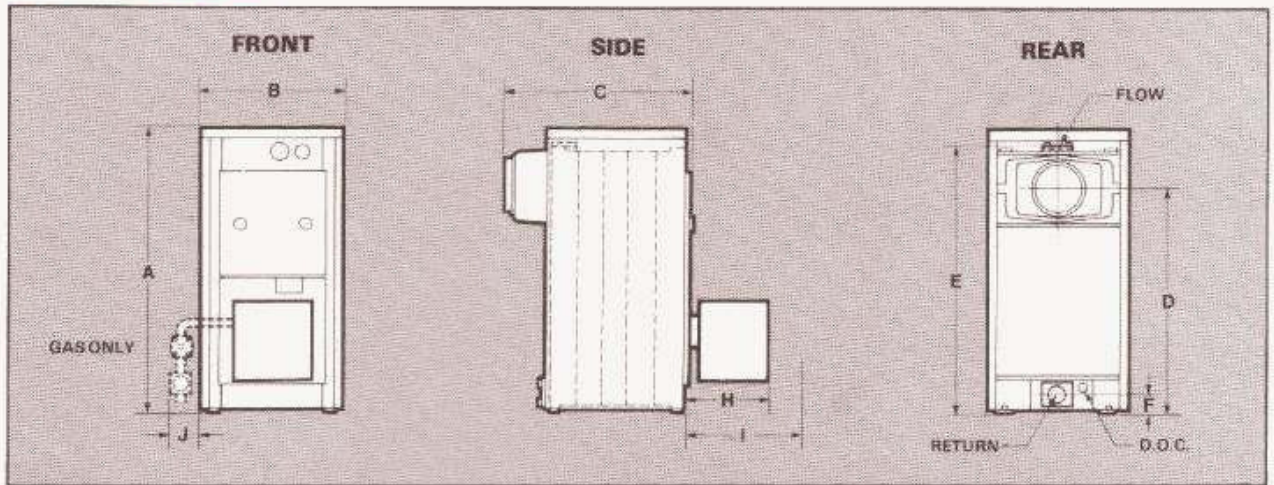

Flue Connection:

1R Range 150mm ϕ socket: 25mm deep
2R Range 200mm ϕ socket: 25mm deep
1 1/2" BSP female

Flow & return connections:

Drain off cock connection:

Fuel connections:

Riello oil 3/8" BSP
Riello gas 1" BSP 1R5 - 2R9
Nu-way gas 1 1/2" BSP 2R10 - 2R12
Nu-way oil 1/4" BSP

Running currents:

Riello oil 1.4 amps max up to 2R11
2.3 amps 2R12
Riello gas 1.85 amps max through range
Nu-way oil 1.3 amps up to 2R8
& gas 2.4 amp 2R9 - 2R12

General Data

Boiler Ref	Heat Output		Firing Rate		Weight inc. Burner kg	Water Content lt	Water Resistance 10°C At mm wg	Flue Gas volume at 15°C : 9% CO ₂ m ³ /h	Draught req'd mm	A mm	B mm	C mm	D mm	E mm	F mm	H' Max mm	I' Max mm	J' Max mm
	kW	Btu/h	Oil l/h	Gas m ³ /h														
1R 5	48.4	165,000	5.5	5.3	256	33	195	91	2	970	402	617	700	857	70	350	460	190
1R 6	60.9	207,630	6.4	6.6	287	38	236	113	2	970	462	694	700	857	70	350	460	190
1R 7	69.5	237,000	7.9	7.8	317	42	269	128	2	970	462	771	700	857	70	350	460	190
1R 8	78.8	269,000	8.6	8.8	353	47	325	146	2	970	462	848	700	857	70	440	550	165
1R 9	88.5	302,000	9.7	9.8	386	51	379	163	2	970	462	925	700	857	70	440	550	165
2R 6	98	334,000	11.8	12.1	487	94	477	181	2	1140	610	862	865	1057	75	440	550	90
2R 7	117	400,000	13.8	14.3	541	109	610	217	2	1140	610	957	865	1057	75	440	550	90
2R 8	135	460,000	15.8	17.2	608	124	704	250	2	1140	610	1062	865	1057	75	440	550	90
2R 9	154	525,000	18.2	18.3	684	138	770	285	2	1140	610	1167	865	1057	75	473	600	115
2R 10	173	590,000	20.7	21.0	758	153	828	320	2	1140	610	1272	865	1057	75	610	830	130
2R 11	191	652,000	22.4	23.2	815	167	927	353	2	1140	610	1377	865	1957	75	610	830	130
2R 12	205	700,000	24.1	25.1	871	182	968	379	2	1140	610	1482	865	1957	75	610	830	130

Notes:

(3) Please see detailed Burner information.

(4) Flue gas volume for gas: oil volume approx 10% less. Flue gas temp. 270°C approx maximum.

Adequate clearance must be allowed around the boiler for access: Rear: sufficient room to connect water and flue; Front & Side 500mm.

Additional Information & Guide Notes

Whenever a boiler is installed it is essential to ensure the following —

1 Adequate flue conditions: the flue must be capable of evacuating the combustion products from the appliance (s) under full load conditions. Always ensure the flue installation is suitable and provides the negative draught specified.

2 Fresh air inlet for combustion and ventilation: the boiler will not operate efficiently and reliably unless there is adequate combustion and ventilation air into the boiler room. Please see BS5440 Pt 2 and CP332:3 as applicable.

The following information is given as a guide.

Position of

Opening Air Direct From Outside

Low level	540cm ² (82in ²) plus 4.5cm ² (0.7in ²) per kilowatt in excess of 60kW total rated input.
High level	270cm ² (41in ²) plus 2.25cm ² (0.35in ²) per kilowatt in excess of 60kW total rated input.

For forced ventilation: 0.03m³/s (76 ft.³/min) per 29kW (100,000 Btu/h) output diverted to low level adjacent to the combustion equipment with a natural draught ventilation outlet at high level.

3 Base requirement: it is recommended that all boilers are positioned on a 50mm high base. Please check Local Authority requirements.

4 System requirement: never exceed maximum recommended working pressure, or temperature. Likewise, the boilers should not operate at working pressures below 2 metres head. Minimum return temperature under normal working conditions 50°C. Maximum temperature drop between flow and return under normal working conditions 25 deg C.

5 A clean, dry, well illuminated boiler room with good access will help to ensure the equipment installed operates to the maximum efficiency. Always take into account the noise level of the equipment, especially when installing forced draught gas equipment.

6 Commissioning and Servicing: however well designed and manufactured the appliance is, it is only capable of operating to its optimum efficiency if it is installed, commissioned and maintained correctly.

G.C. Appliance Nos.

1R Series

1R5	41 862 17
1R6	41 862 18
1R7	41 862 19
1R8	41 862 20
1R9	41 862 21

RM Series

RM22	41 862 38
RM32	41 862 39
RM42	41 862 34
RM52	41 862 35
RM62	41 862 36
RM72	41 862 37

RMG Series

RMG8	41 862 31
RMG9	41 862 33
RMG10	41 862 32

RS Series

RS6	41 862 22
RS7	41 862 23
RS8	41 862 24
RS9	41 862 25
RS10	41 862 26
RS11	41 862 27
RS12	41 862 28
RS13	41 862 29
RS14	41 862 30

POWRMATIC — Europe's No.1 warm Air Heater manufacturer but also big in Gas and Oil Unit Heaters, Radiant Plaque and Tube Heaters, Stainless Steel Flue, Ventilation Equipment, Thermal Economisers, Sabiana Unit Heaters, Convectors, Commercial Electric Storage Heaters and Quartz Linear Lamp Heaters. All supported by Nationwide Sales, Stockists, Service and Spares operation.

 **powrmatic**
The World's Favourite Air Heater

Powrmatic Ltd., Ilminster, Somerset, TA19 9PQ Tel: 0460 53535 Telex: 46323 POWRIL G Fax: 0460 52341

Every effort is made to ensure accuracy at time of going to press. However as part of our policy of continual product improvement, we reserve the right to alter specifications without prior notice.